

PLAN

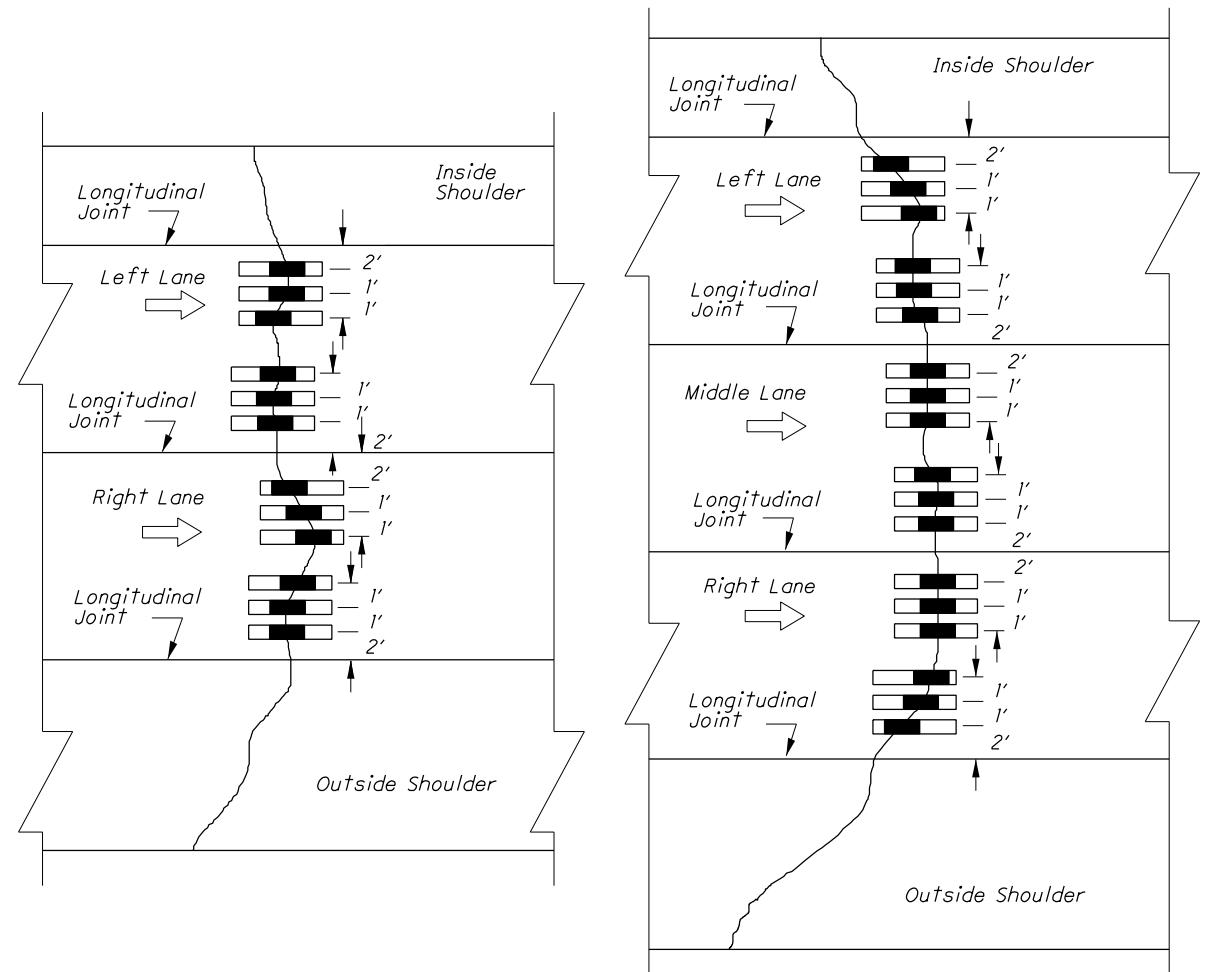

RETROFIT DOWEL BAR SPACING

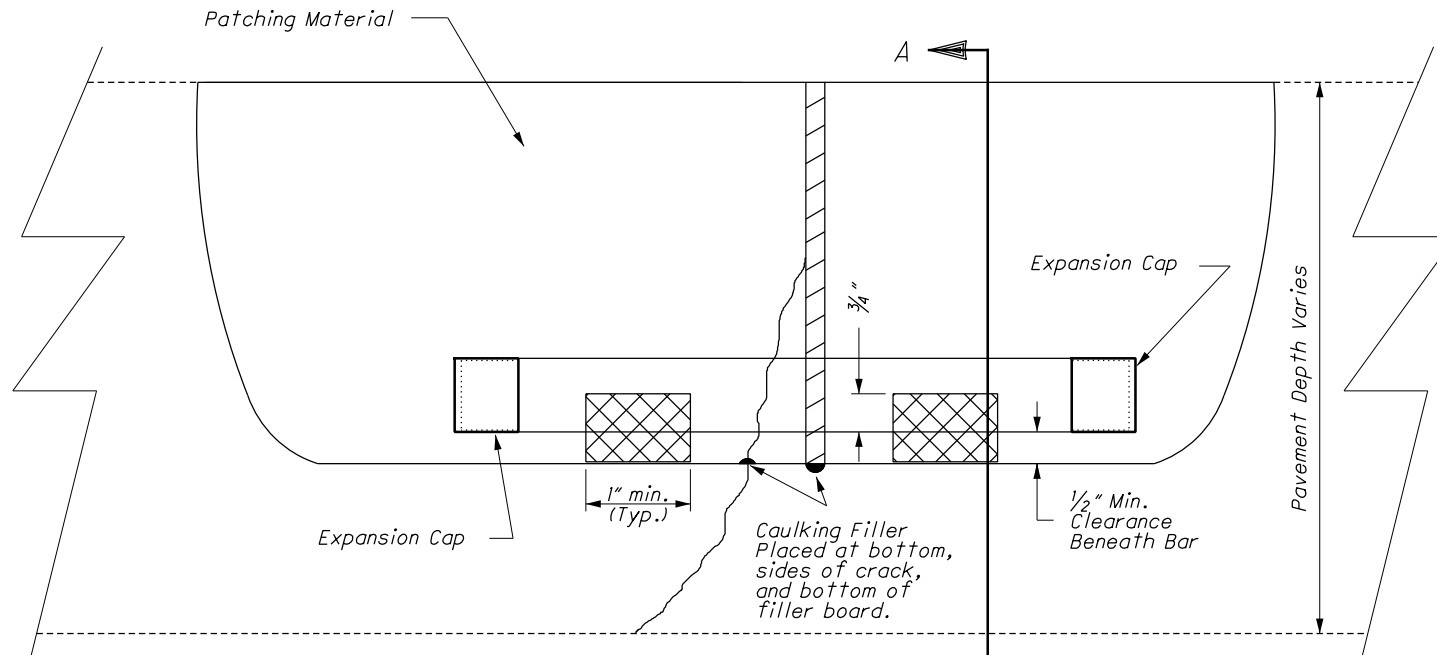

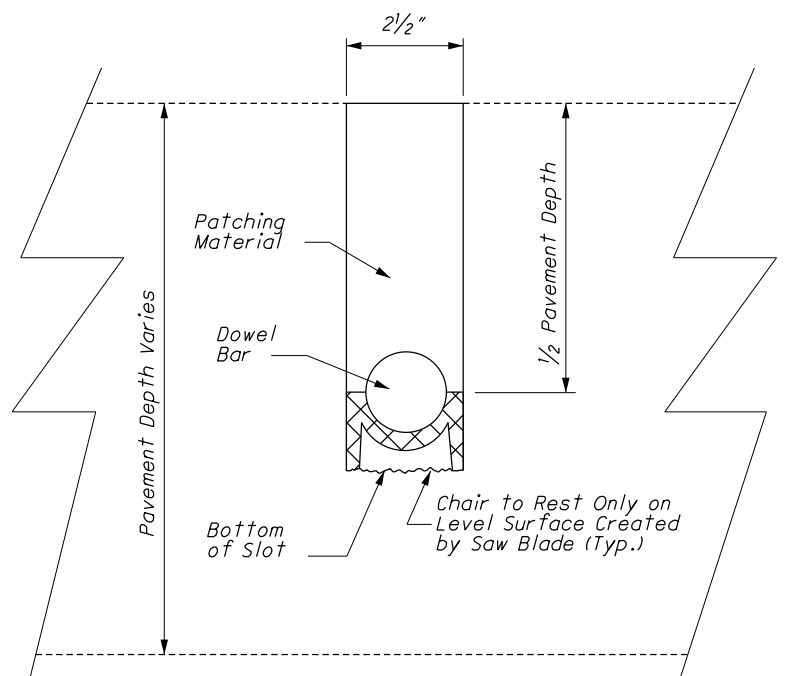

ELEVATION



SECTION A-A

NOTES

- Cracks to be retrofitted will be marked on the pavement by the Engineer.
-  Prefabricated chair as approved by the Engineer.
-  Chair to Rest Only on Level Surface Created by Saw Blade (Typ.)

1/2" x 18" RETROFIT DOWEL BAR

THIS DRAWING REPLACES BP-2.6 DATED 7-18-08.

SCD NUMBER
BP-2.6

STANDARD ROADWAY CONSTRUCTION DRAWING
LOAD TRANSFER RETROFIT

OFFICE OF
**PAVEMENT
ENGINEERING**

STATE ENGINEER
D. Miller

STATE OF OHIO DEPARTMENT OF
TRANSPORTATION ADMINISTRATOR
David J. Humphrey

REVISION DATE
7-15-2016

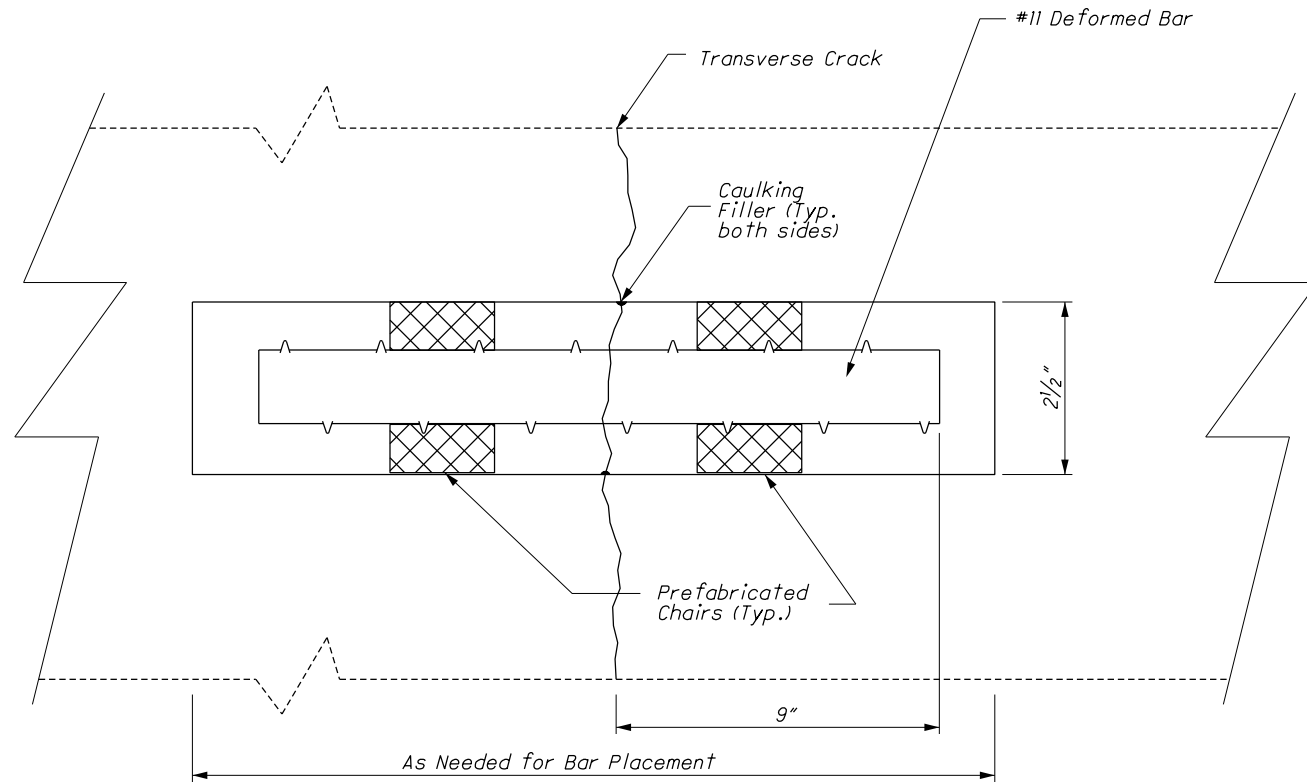

PLAN

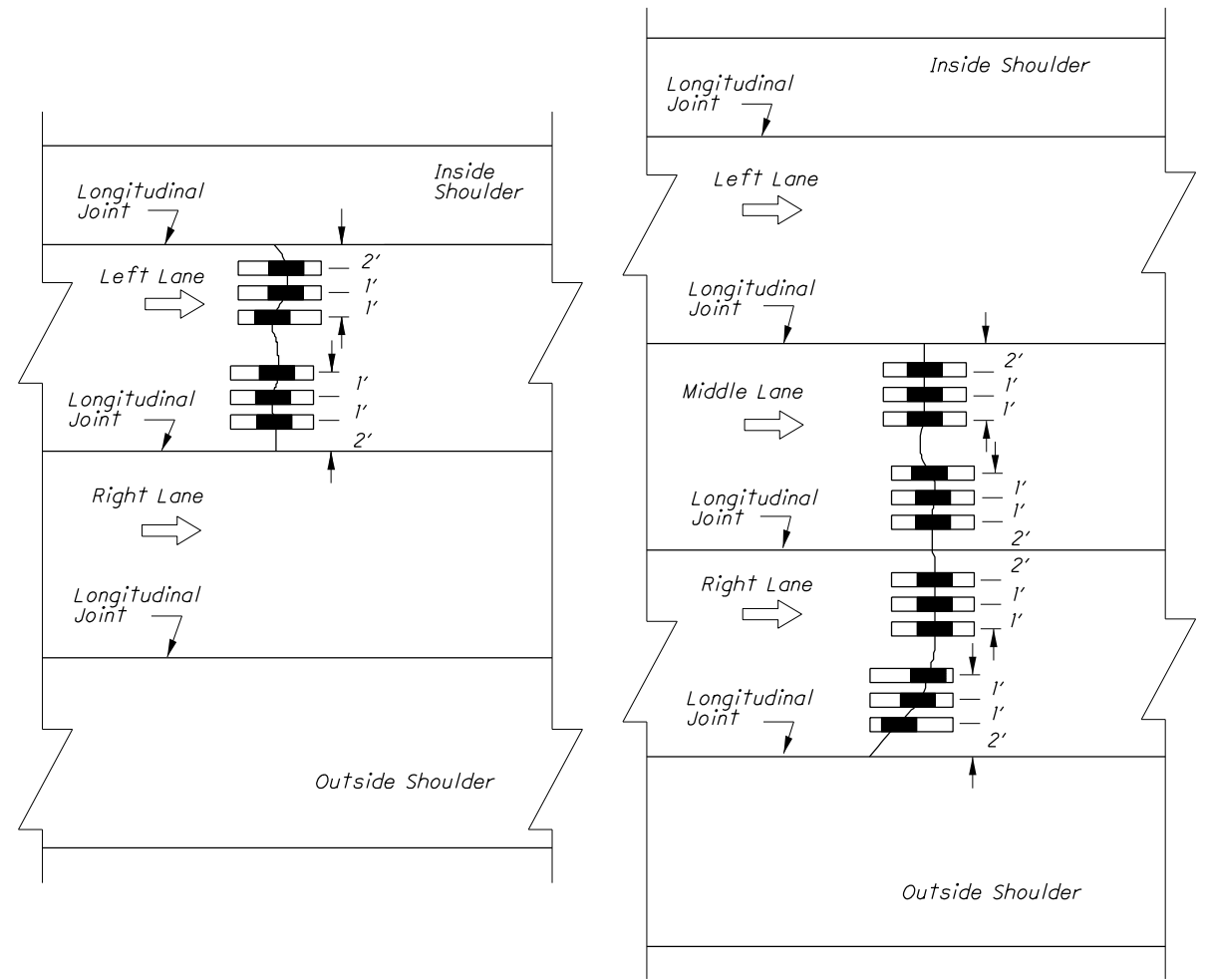

RETROFIT DEFORMED BAR SPACING

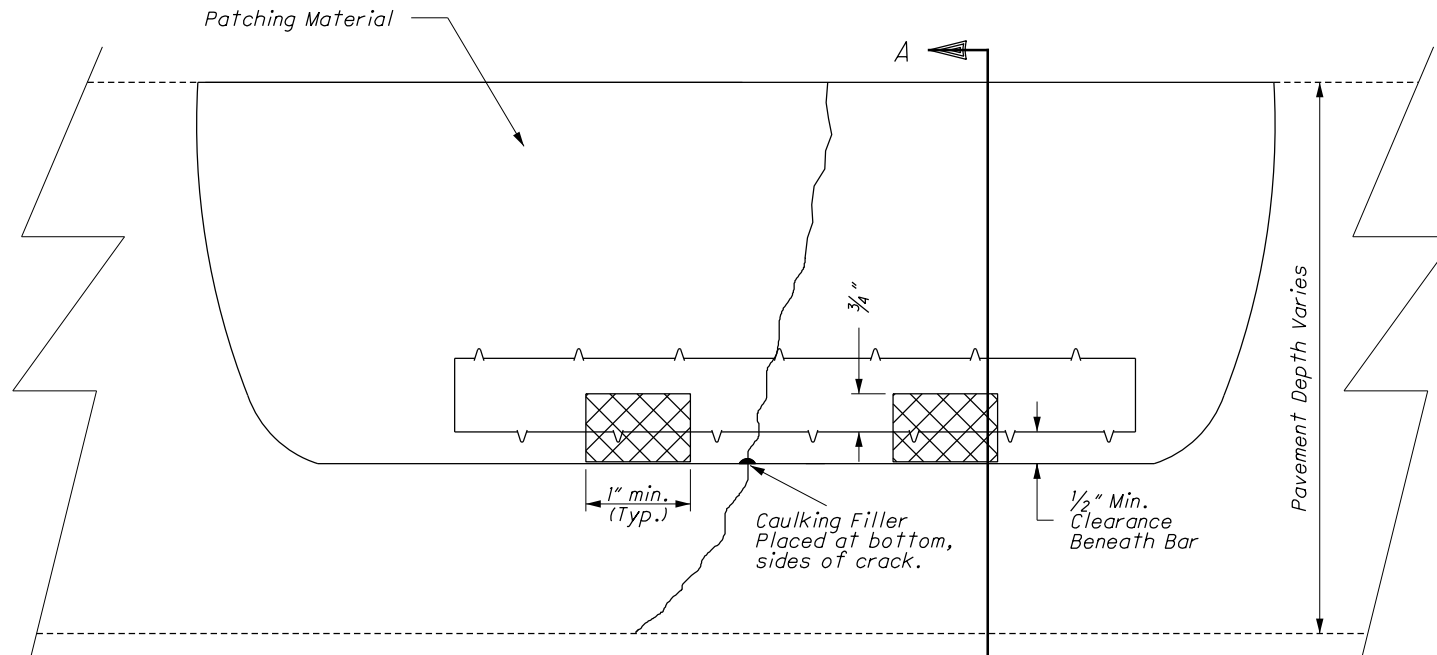

ELEVATION

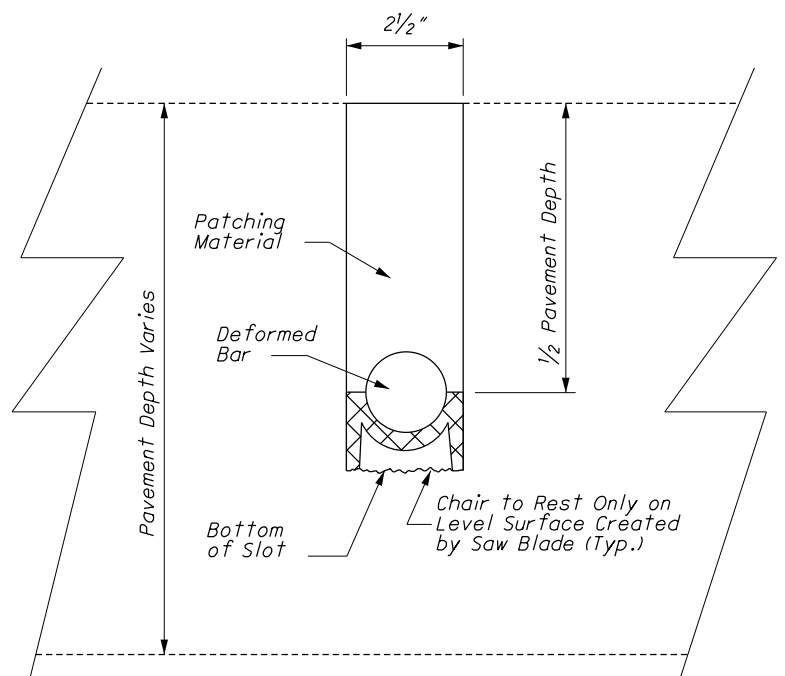

SECTION A-A

NOTES

- Cracks to be retrofitted will be marked on the pavement by the Engineer.
-  Prefabricated chair as approved by the Engineer.

#11 RETROFIT DEFORMED BAR

THIS DRAWING REPLACES BP-2.6 DATED 7-18-08.

SD NUMBER
BP-2.6

STANDARD ROADWAY CONSTRUCTION DRAWING
LOAD TRANSFER RETROFIT

OFFICE OF
**PAVEMENT
ENGINEERING**

STATE ENGINEER
D. Miller

STATE OF OHIO DEPARTMENT OF
TRANSPORTATION ADMINISTRATOR
David J. Humphrey

REVISION DATE
7-15-2016