

DIMENSION ① IS 6" OR 8" DEPENDING ON BOX BEAM DEPTH. SEE PROJECT PLANS AND POST ANCHORAGE DETAILS, PRESTRESSED CONCRETE BOX BEAMS. FOR DIMENSION ② SEE PROJECT PLANS.

(FOR USE WITH PRESTRESSED CONCRETE BOX BEAMS)

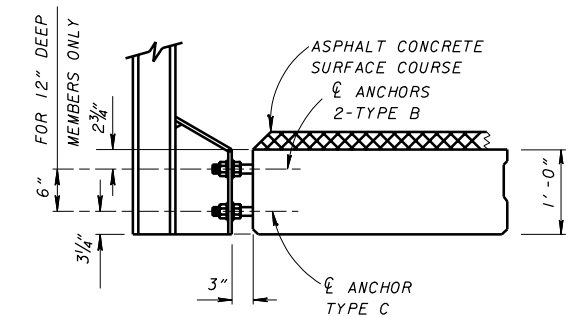

POST ANCHORAGE DETAILS FOR PRESTRESSED CONCRETE BOX BEAMS

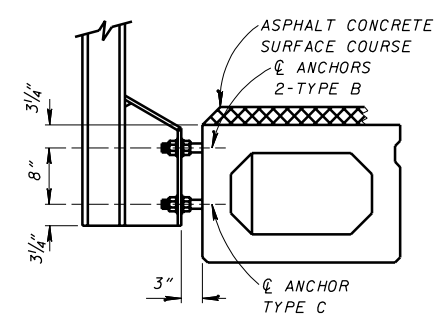
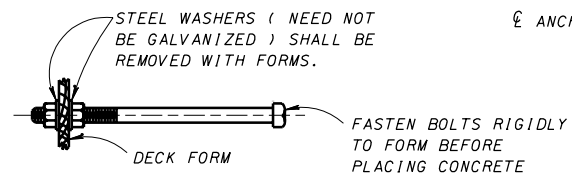
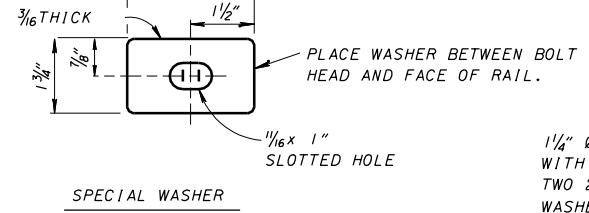

1 1/4" Ø x 20" MACHINE BOLT WITH THREE HEX NUTS AND TWO 2 1/2" x 3 1/2" x 5/16" PLATE WASHERS, AS NOTED.

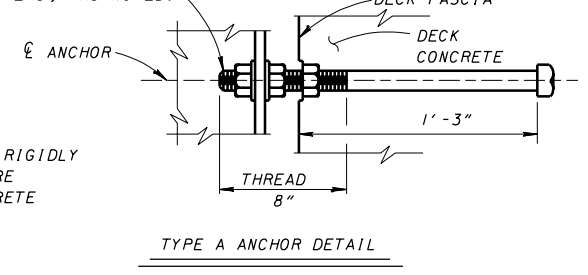

TYPE A ANCHORS SHOULD ONLY BE USED ON PROJECTS WHERE THE ORIGINAL ANCHORS WERE TYPE A AND ALL ANCHORS ON ANY SINGLE STRUCTURE ARE NOT BEING REMOVED OR REPLACED

TWO 1 1/4" x 8" STUDS WITH MACHINE THREADS FULL LENGTH AND TWO HEX NUTS AND TWO 2 1/2" x 3 1/2" x 5/16" PLATE WASHERS PER STUD.

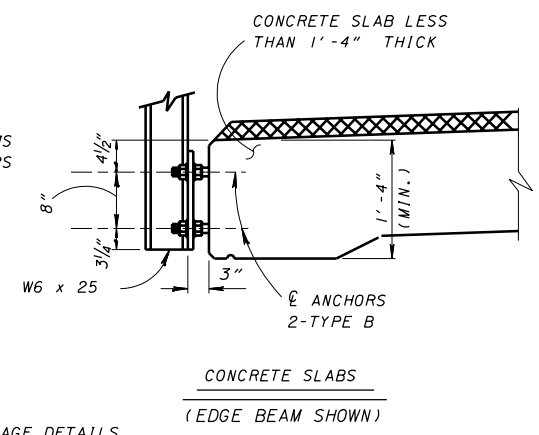
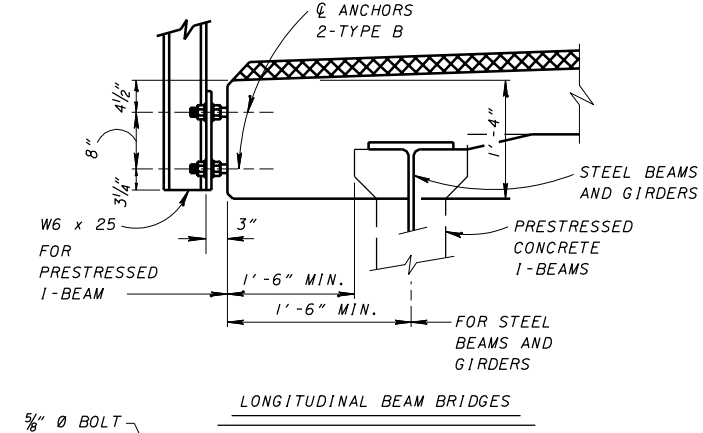
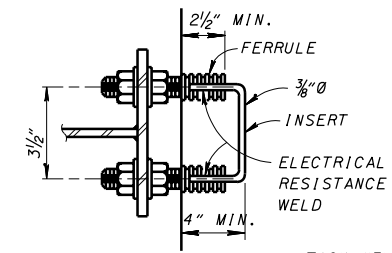
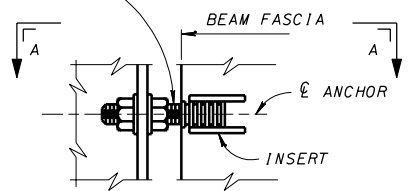

POST ANCHORAGE DETAILS (NOT FOR USE WITH PRESTRESSED BOX BEAMS)

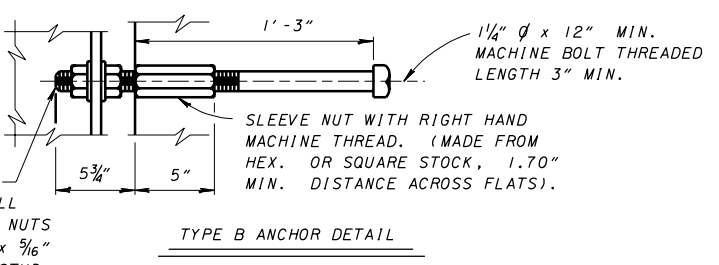
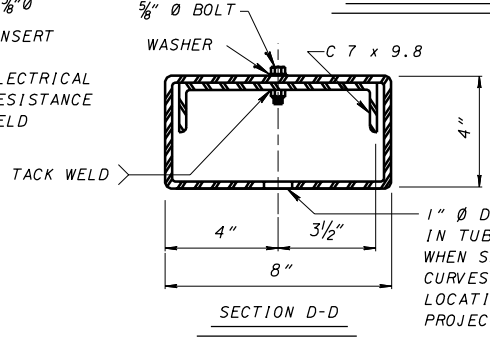

1 1/4" x 8" STUD WITH MACHINE THREADS FULL LENGTH AND TWO HEX NUTS AND TWO 2 1/2" x 3 1/2" x 5/16" PLATE WASHERS PER STUD

MATERIAL: ALL ANCHOR BOLTS, NUTS AND STUDS SHALL CONFORM TO THE PHYSICAL PROPERTIES OF ASTM-A325 EXCEPT THAT THE ELONGATION SHALL BE 10% AND THE THREAD REQUIREMENTS SHALL BE WAIVED. THE CHEMICAL PROPERTIES ARE WAIVED.

STEEL TUBING SHALL BE AS PER ITEM 707.10. ALL GUARDRAIL POSTS AND PLATE WASHERS SHALL BE ASTM A709 GRADE 36 OR 50.

GALVANIZING: ALL GUARDRAIL POSTS, TUBES, HARDWARE AND ACCESSORIES SHALL BE GALVANIZED IN ACCORDANCE WITH 711.02, EXCEPT AS OTHERWISE NOTED.

TYPE C ANCHOR INSERTS OF A DIFFERENT TYPE MAY BE PROVIDED IF APPROVED BY THE DIRECTOR.