



Some questions

- **What is the TMA?**
- **Why a TMC?**
- **What will the Chicago TMC do?**
- **What's done so far?**
 - **Existing systems**
 - **Related projects**
- **What's next?**

An Overview



- **Signal systems**
- **Traveler information**
- **Transit and traffic management**
- **Database development & integration**
- **911 Center**
- **Operations Center**
- **Chicago Incident Center**
- **Joint Operations Center**

- **Chicago Traffic Management Center**

Providing Traveler Information

Creating Public/Private Partnerships



Making Transit More Effective



Reducing Traffic Congestion



Supporting Homeland Security



Resolving Truck Transport Issues



Managing Incidents



Promoting Interagency Cooperation



Interagency Communications



Integrating Traffic Management Centers

10 Recommendations



- 1) **Adopt/adapt existing technologies**
- 2) **Pursue multi-disciplinary approaches**
- 3) **Create operational roadmap with stakeholders**
- 4) **Use diversified acquisition strategy, open standards**
- 5) **Work closely with technology providers**
- 6) **Emphasize capabilities for routine operations**
- 7) **Employ metrics for cost/benefit decisions**
- 8) **Perform independent assessments**
- 9) **Develop cadre of people with expertise**
- 10) **Sustain an integrated network of centers**

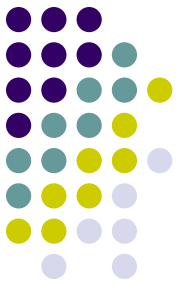

Interesting source of these recommendations:

Improving Disaster Management: The Role of IT in Mitigation, Preparedness, Response and Recovery

Adapted from:

Draft report prepared by NSF for OMB and FEMA in response to Sec. 214 of the “E-Government Act of 2002”

TMC Development Themes



- **Information Management and Communications**
 - Wired and wireless communications
 - Data sharing and mining
 - Dealing with uncertain information
- **Software Tools and Services**
 - Open architecture, standards-based
 - Computer vision, sensor fusion, prediction, modeling, real-time negotiation
- **Human Factors**
 - Interfaces, privacy, institutional issues

Use System Engineering Process



Capital project development lifecycle tasks

Transportation Planning	Identify Project Needs	Project Initial Doc	Form Proj Dev Team	Prepare Project Study	Secure Project Program	Prepare Draft Report	Perform Environ Report	Secure Project Approval	PS&E Development Approval	Complete Project Design	Prepare & Advertise Project	Construct Project	Project Close-out	Operations and Maintenance	Rehab
	Identify Project*		Secure Project Program*		Perform Environmental*										

* Applies to local agencies only

ITS Project phase definitions

Architecture Development	Concept Exploration and Feasibility Assessment	Project Planning and Concept of Operations	System Definition	System Development and Integration and initial deployment	Operations and Maintenance	System Retirement Replacement
Phase -1	Phase 0	Phase 1	Phase 2	Phase 3	Phase 4	Phase 5

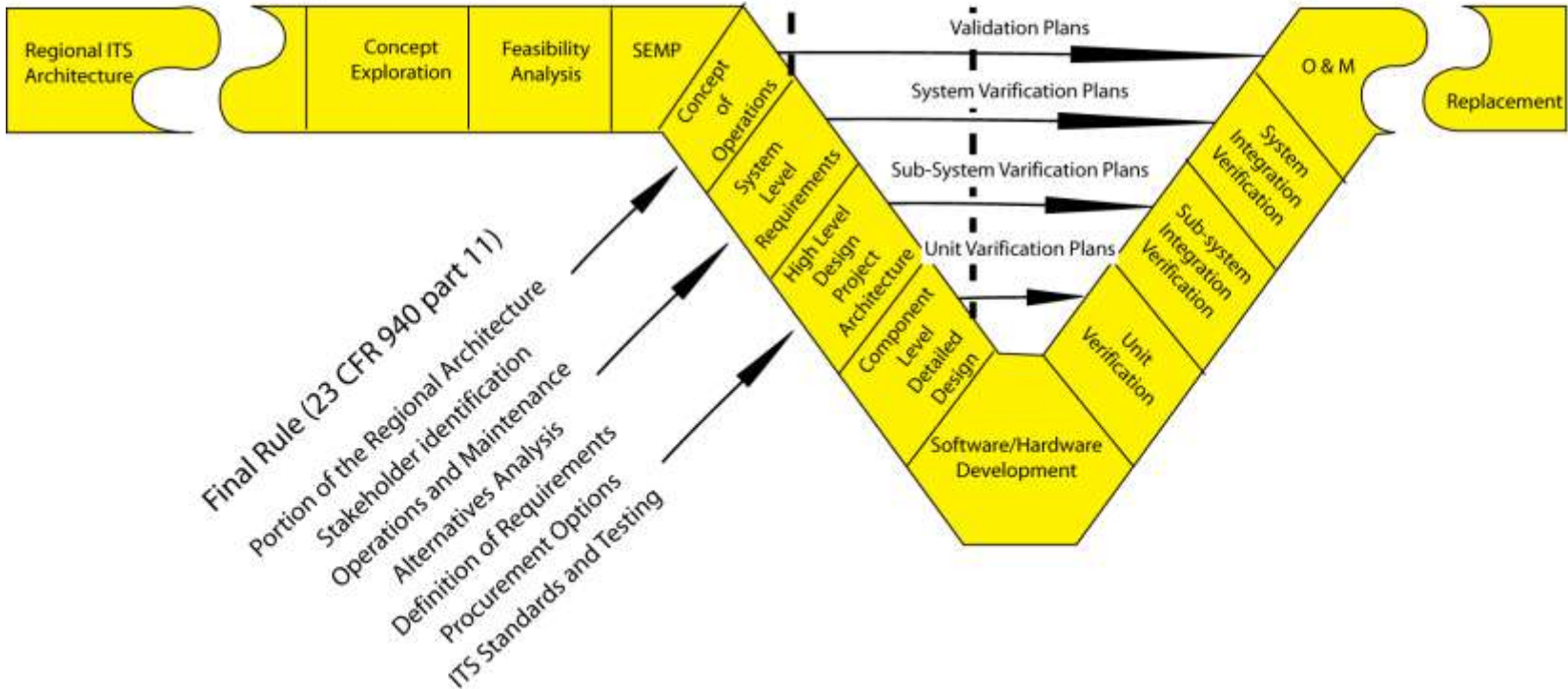

Crosscutting Activities

Completed TMC Concept of Operations, Architecture, Project Development Report, Requirements and Specifications

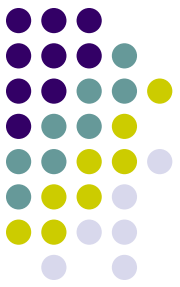

- **Defines roles and responsibilities**
 - WHAT will be done**
 - WHO will do it**
 - But not HOW it will be done**
- **Provides framework project architecture**
- **Establishes the core requirements**

... build on existing regional integration

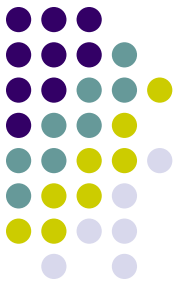



... use the NE Illinois Regional Architecture

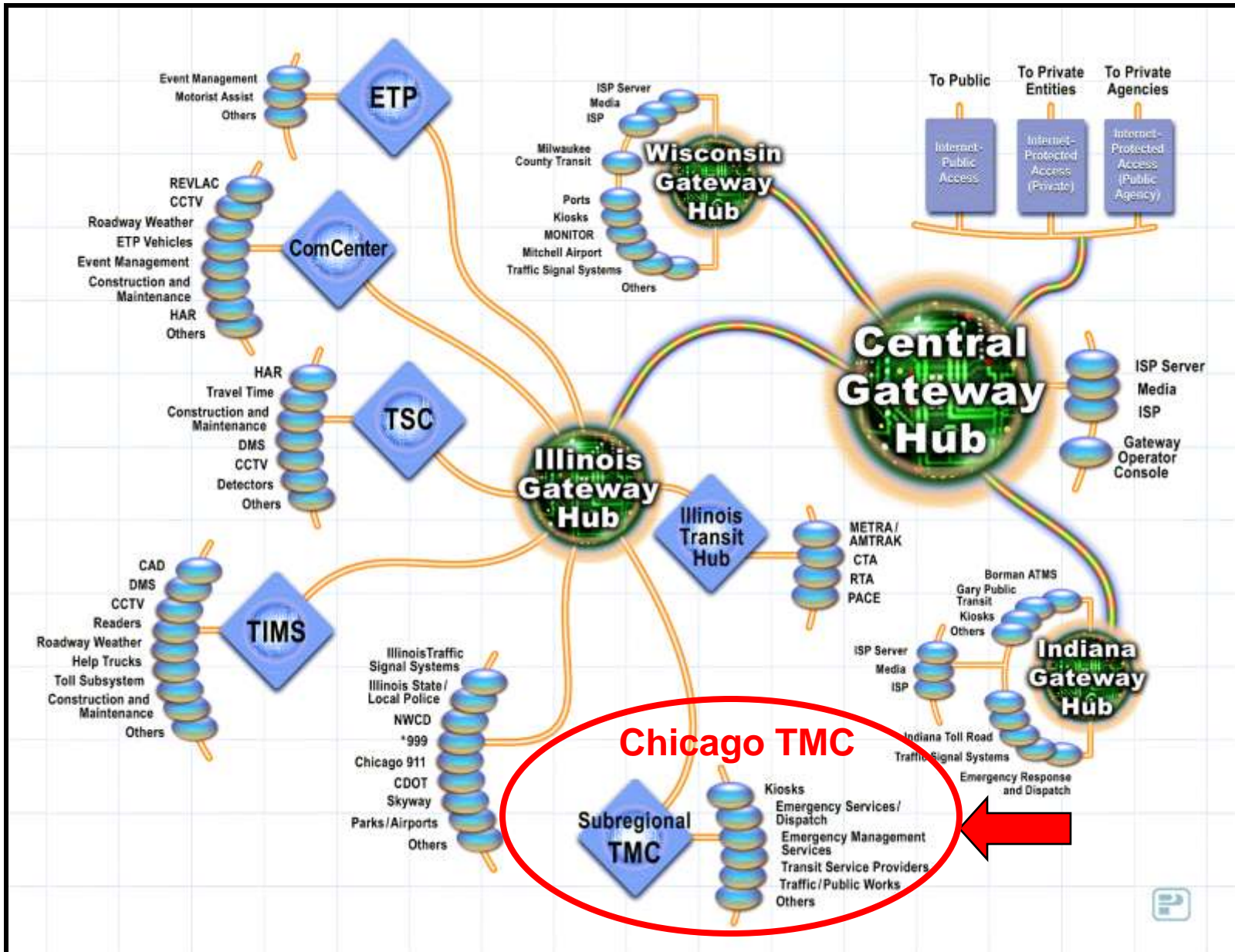
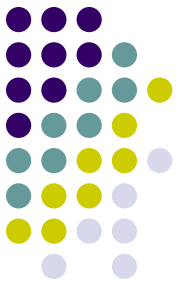

... apply available standards

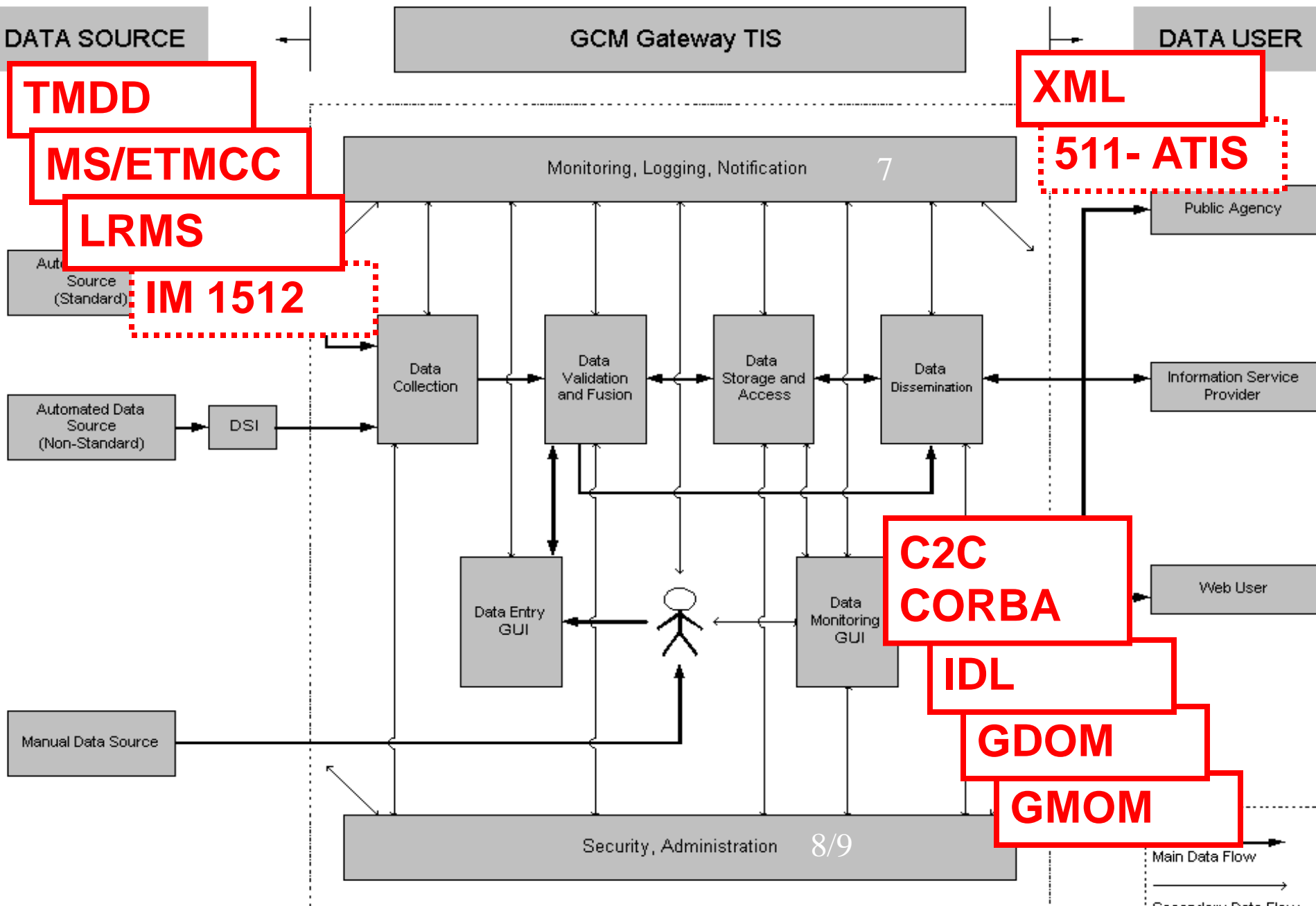

Chicago TMC Info Flows

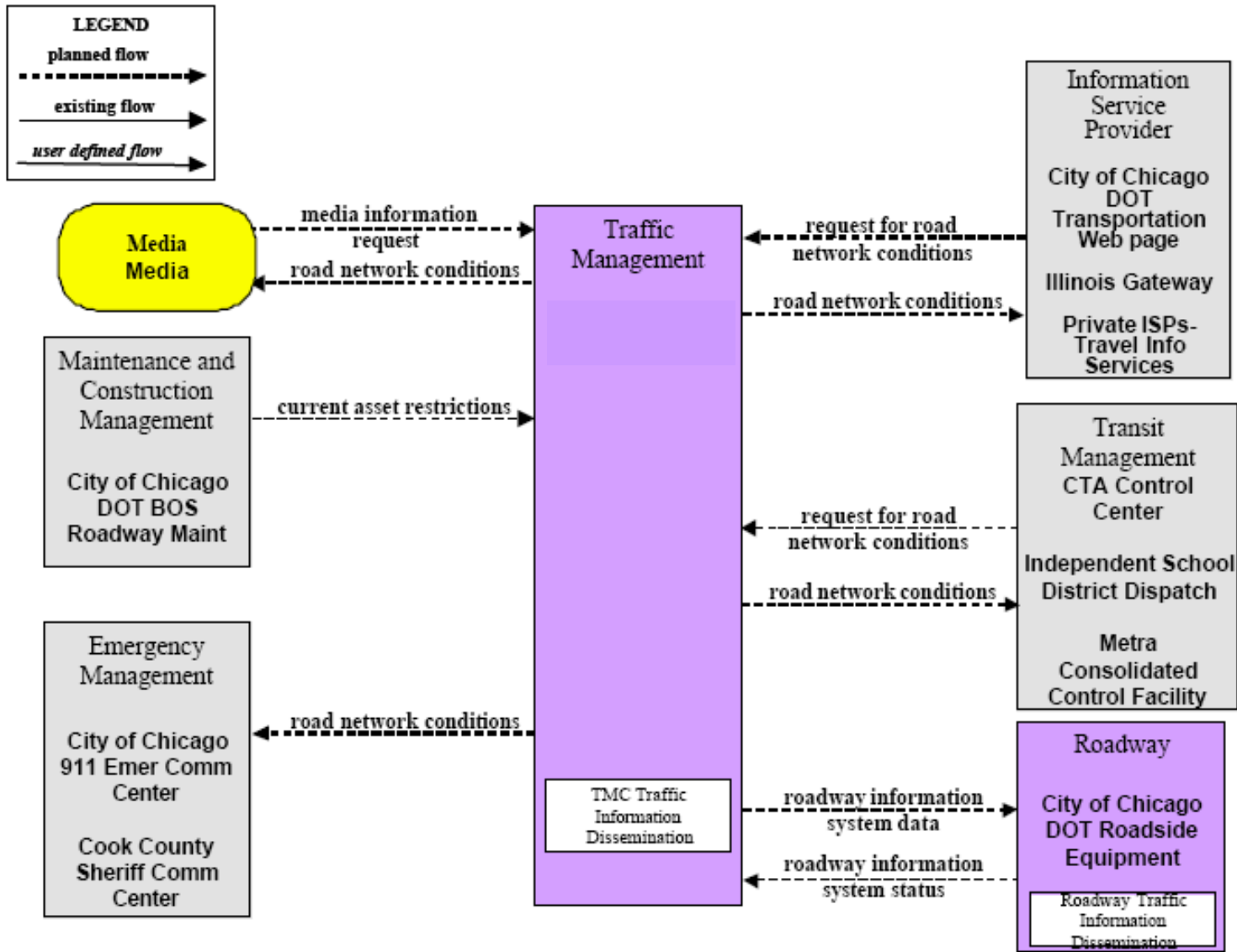
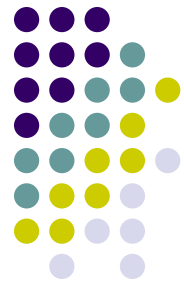

... share data



Planning and Research

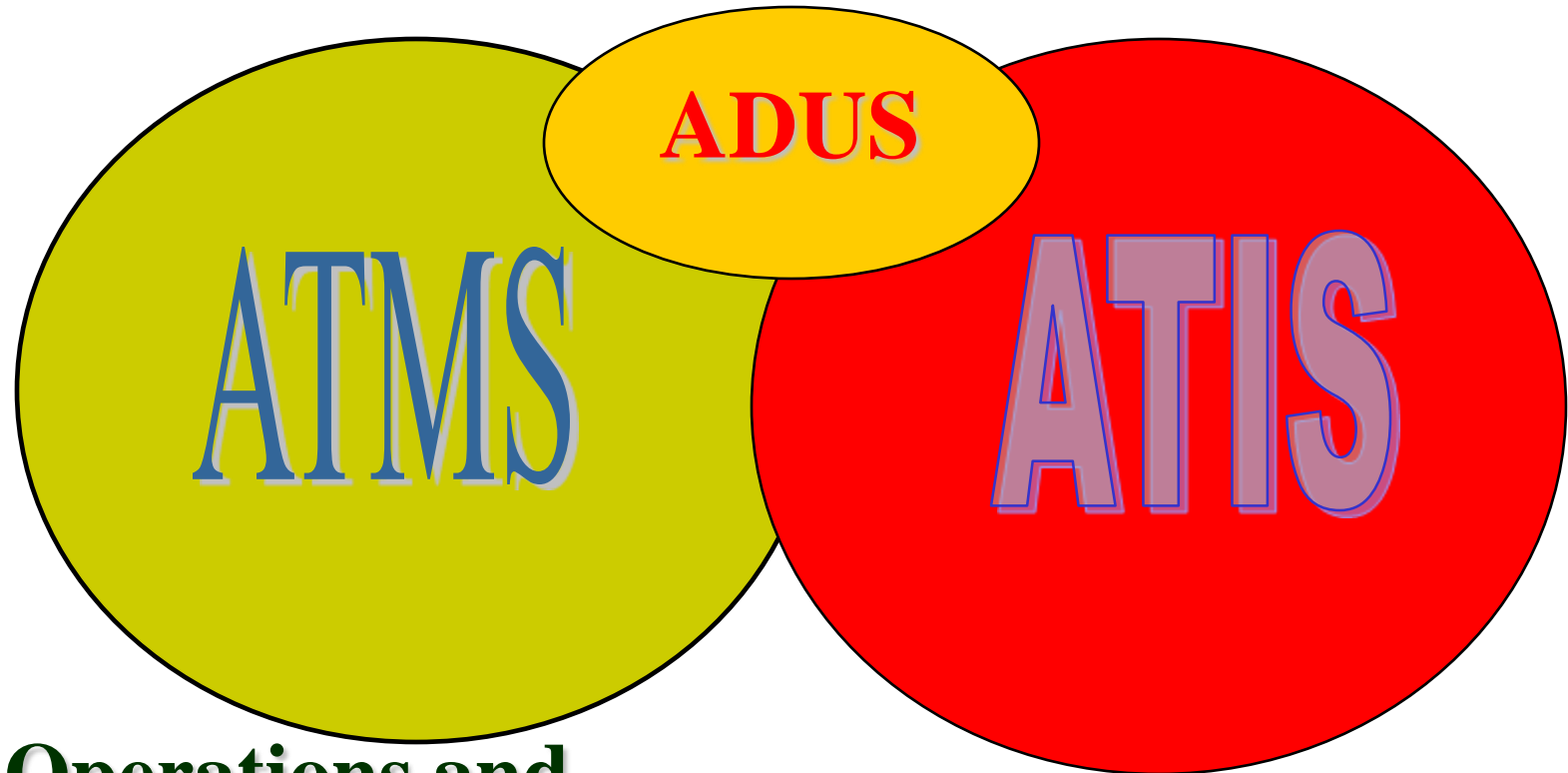

**Operations and
Management**

**Traveler
Information**

Many ITS Tools in Chicago

- **Traffic responsive, adaptive signal systems**
- **Video detection, surveillance systems**
- **Signal pre-emption, priority systems**
- **Computer Aided Dispatch (CAD) systems**
- **Traveler information systems**
- **Vehicle navigation, tracking systems**
- **Enforcement systems - cameras**
- **Safety systems – traffic calming devices**
- **Permit, Towing, Snow Command systems and services**

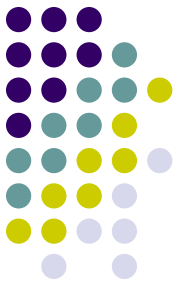

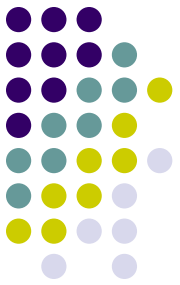

Signal System Tools

- Time-based Coordination
- Closed Loop Interconnects (CLMATs)
- Centralized Signal Control (MIST)
- Responsive Signal Control
- Adaptive Signal Control (RT Tracs pilot)

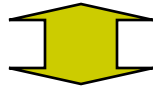

- City-wide signal optimization program
- Smart corridors
- Response plans
- Central control

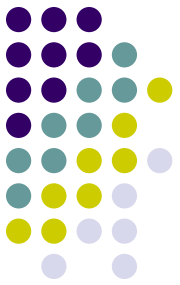

Video System Tools

- **Video Detection**
- **Video Surveillance**

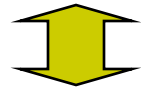

- **Multiple video systems**
- **High-bandwidth communications backbone**
- **Shared use of cameras**

Chicago Signal Systems in place:

City of Chicago Signal Interconnect



- ➔ Over 26,000 intersections
- ➔ Over 2,900 Signals
- ➔ 476 intersections interconnected in 25 systems
 - MIST (6)
 - CLMATS (19)

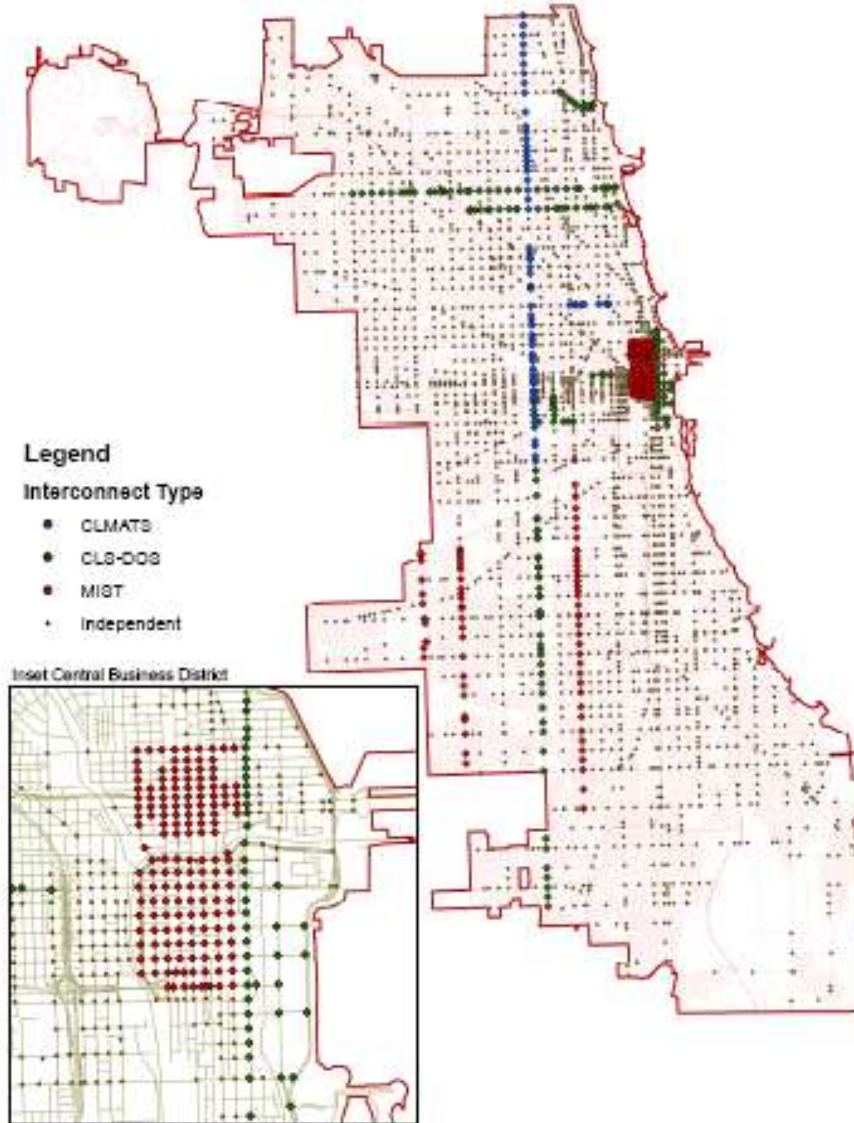

Video Detection & Surveillance



System & Activation

Surveillance

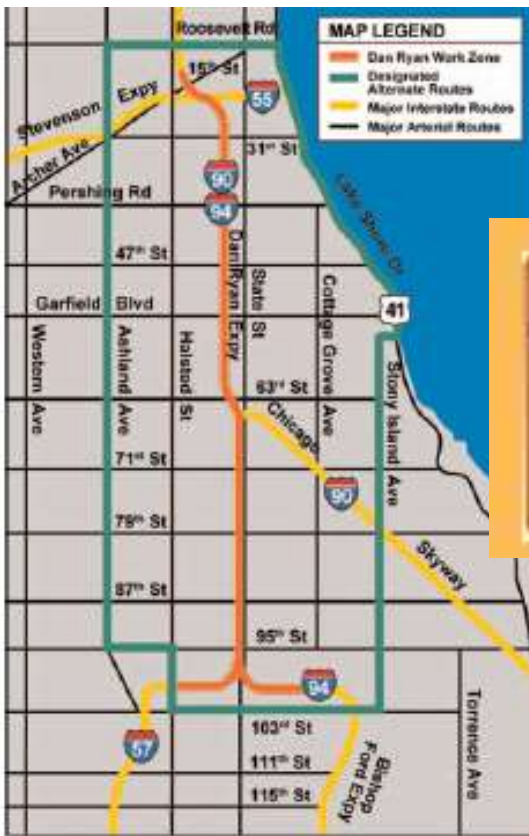
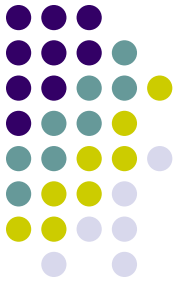

City of Chicago Signal Interconnect

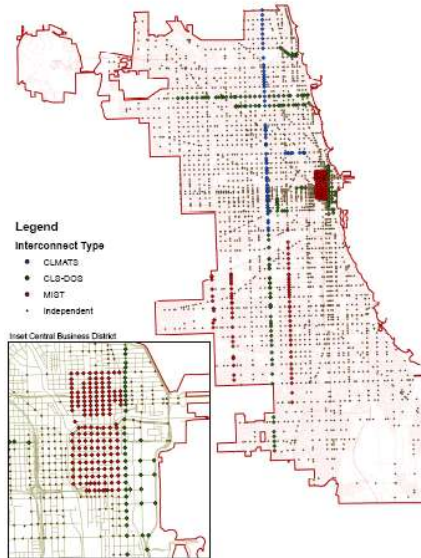

- **13.8 miles**
- **39 intersections**
- **Operated under MIST from Chicago TMC**
- **26,000-44,000 ADT**

Project:
Ashland Avenue
Alternate for Dan
Ryan Reconstruction

Project Lead:
Chicago Office of
Emergency Management
and Communications
(OEMC)

Project Team:
Chicago Department of
Transportation
Chicago Skyway
Illinois Department of
Transportation

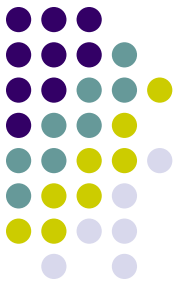

Pre-emption, Priority Tools

- **Emergency Vehicle Pre-emption**
- **Highway Rail Interconnects**
- **Transit Signal Priority**

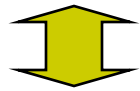

- **Western Ave. Transit Signal Priority System Pilot**
- **Cicero Ave. Smart Corridor RR Gate Information**

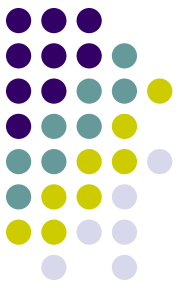

Traveler Information Tools

- **Broadcast Media**
- **Dynamic Message Signs**
- **Highway Advisory Radio**
- **Subscription Services, e-Mail Alerts**
- **Mobile, Wireless Services**
- **Internet**

<http://www.egov.cityofchicago.org/city/webportal/home.do>

Go to: “Traffic & Transportation” and “Travel & Transportation”
for Traffic Advisories, Street Closures, etc.

Arterial DMS



Regional Traveler Information website

www.gcmtravel.com

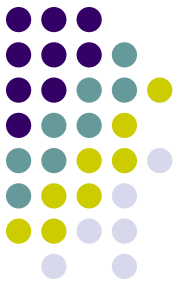

Gary-Chicago-Milwaukee Corridor - Microsoft Internet Explorer

Address: http://www.gcmtravel.com/gcm/maps_chicago.jsp

GCM Travel
Gary • Chicago • Milwaukee Corridor Transportation Information

Home My Travel Maps Reports Cameras Major Links Help

Map Navigator

Map Legend

Icon	Description
	Chicago-oriented Travel Times (mins)
	Link Travel Times (mins)
	Incident
	Heavy Congestion
	Medium Congestion
	Light Congestion
	Uncongested
	Unknown Congestion
	Point Construction
	Section Construction
	Airport
	Message Sign
	Camera

Last IDOT egressway travel time update @ 09:10:00 AM CDT. Last Tollway travel time update @ 09:15:19 AM CDT.

[Site Sponsor](#) | [Requirements](#) | [Privacy](#) | [Disclaimer](#) | [History](#)

Please send comments or suggestions to GCM@icm.com

This site is best viewed in [Internet Explorer 5.0+](#) or [Netscape 6.0+](#) with [cookies](#) and [Java Script](#) enabled.

Wed Oct 25 09:15:20 CDT 2006

start | Microsoft Word | Adobe Reader | Gary-Chicago-M... | Microsoft Excel | Removable Disk | Microsoft Power...

Travel times
Congestion
DMS
Cameras
Construction
Incidents

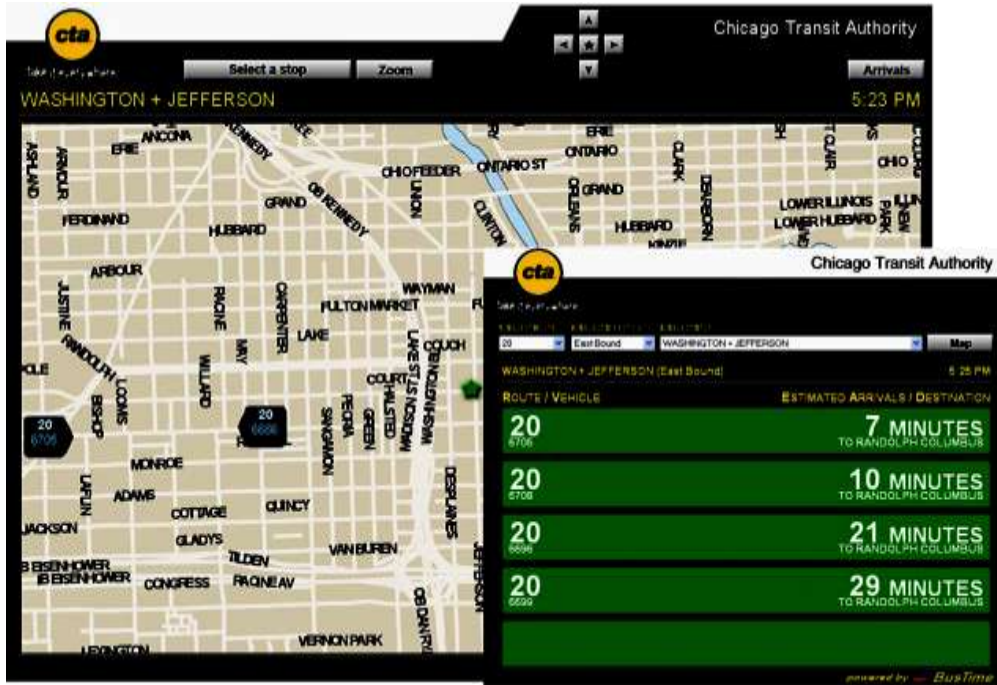
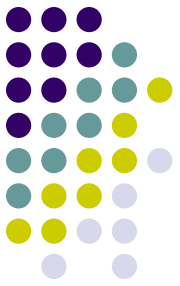

Project:
CTA Bus Tracker

www.ctabustracker.com

Project Lead:
Chicago Transit Authority

Project Team:
CTA Technology Management
CTA Transit Operations
Clever Devices



Chicago Transit Authority

CTA Bus Tracker

Enforcement Tools

- **Red-light cameras**
- **TMA Traffic Control Aides**

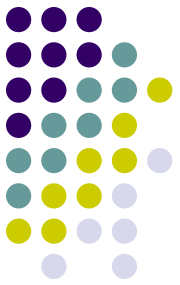

Red Light Running

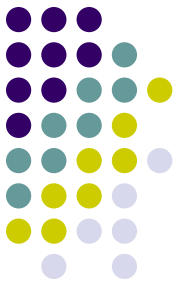



Safety Tools

- **Pedestrian Countdown Signals**
- **Pedestrian Activation/Presence Detection**
- **Audio/Visual Notification**
- **Traffic Calming**

Ped Countdown Signal



Chicago OEMC: Co-Location of Public Safety, Emergency, and Transportation Operations

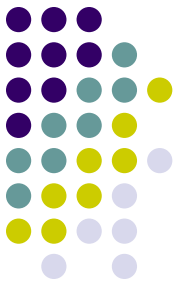

Chicago TMC Integration

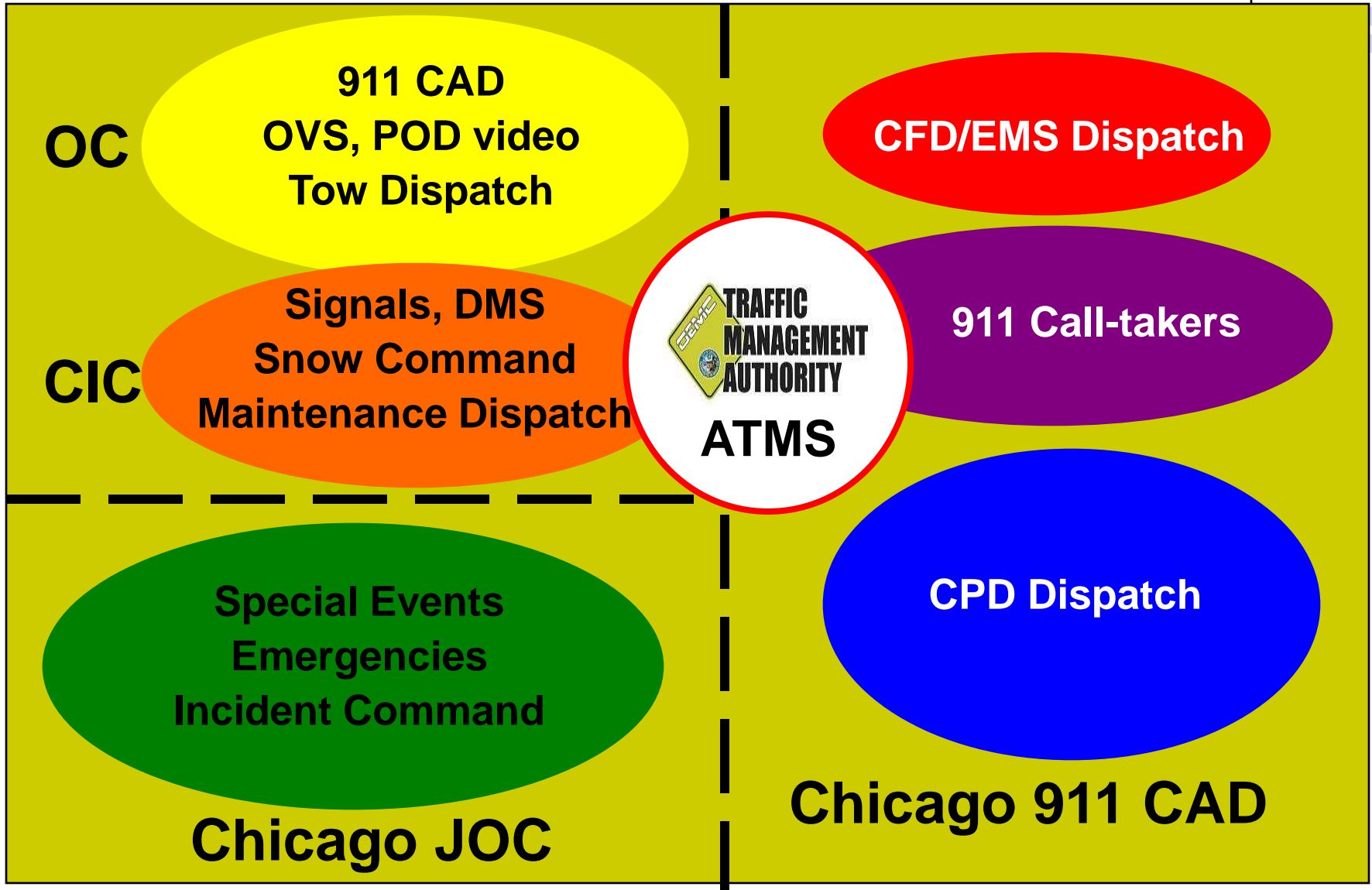
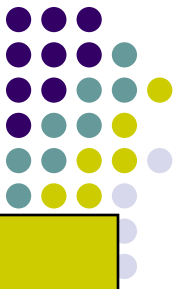

911 Operations Floor



911 – Police, Fire, Emergency Computer Aided Dispatch

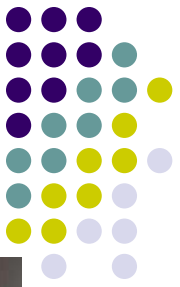

Arterial Performance Monitoring System

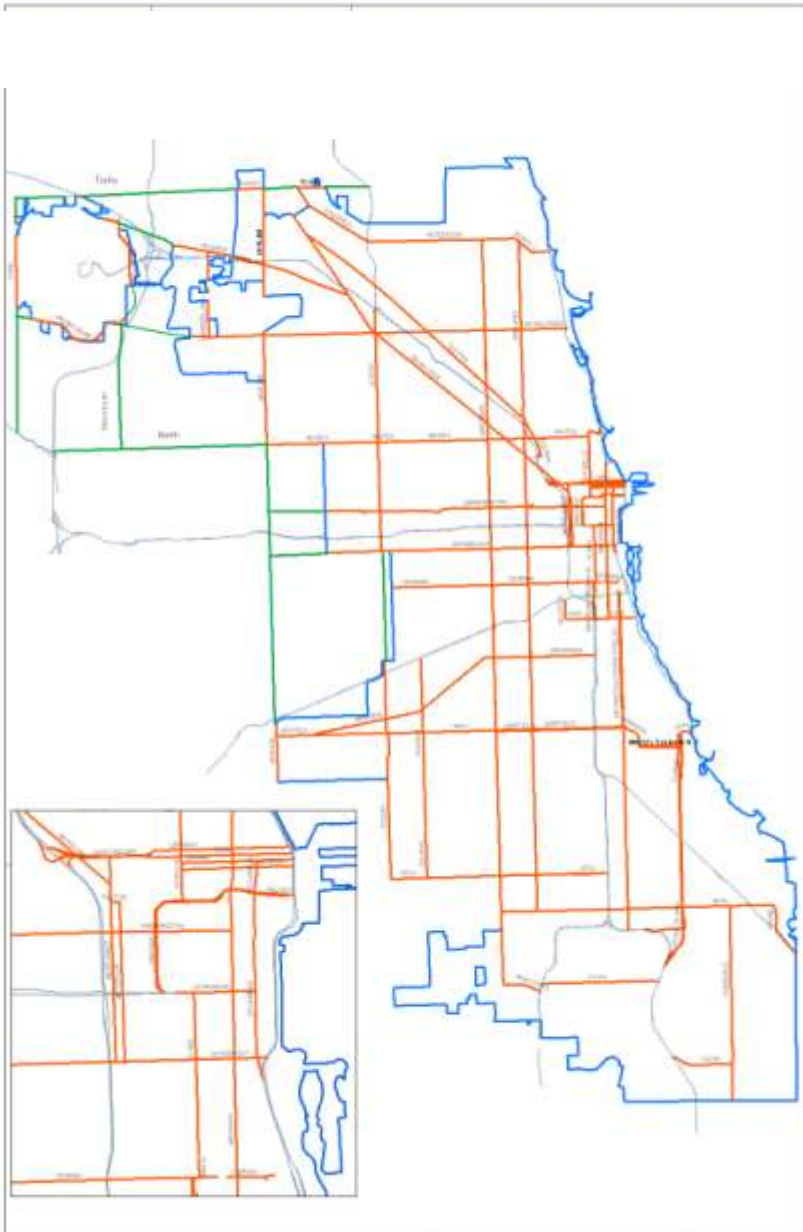

- About 300 miles of major arterials
- Includes Strategic Regional Arterials
- A connected network of routes to supplement expressways
- Can support responsive traffic control strategies

Operations Center

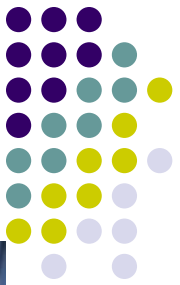

Chicago Incident Center



Signal (MIST), DMS, CCTV Workstations

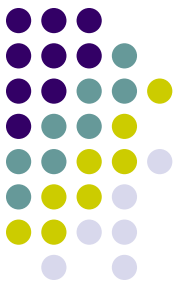

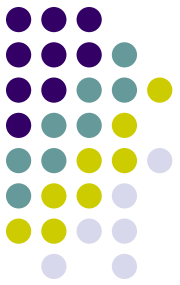



TMC - Four Phases

- **Phase 1 Concept engineering, ConOps – completed 2003**
- **Phase 2 Re-validate concept, requirements, functional specs, system manager – currently underway**
- **Phase 3 Construction, software development, integration – RFP in 2009, 18 months**
- **Phase 4 Operation –September 2010, in time for 2016 Olympics**

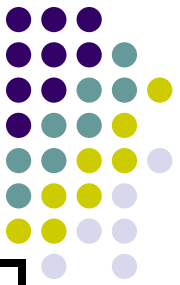
ATMS = 13 Subsystems



1) Incident Management Subsystem (IMS)	2) Video (CCTV) Subsystem	3) Variable Message Sign (VMS) Subsystem
4) Highway Advisory Radio (HAR) Subsystem	5) Map Display Subsystem (MDS)	6) Alarm Emergency Management Subsystem (AEMS)
7) Data Warehouse Subsystem	8) External Input Subsystem	9) External Output Subsystem
10) Workstations Subsystem (GUI)	11) Administrations Subsystem (Login, Permissions)	12) Traffic Signal Subsystem
13) Arterial Performance Monitoring Subsystem (APMS)	Others?	

Chicago OEMC ATMS Overview

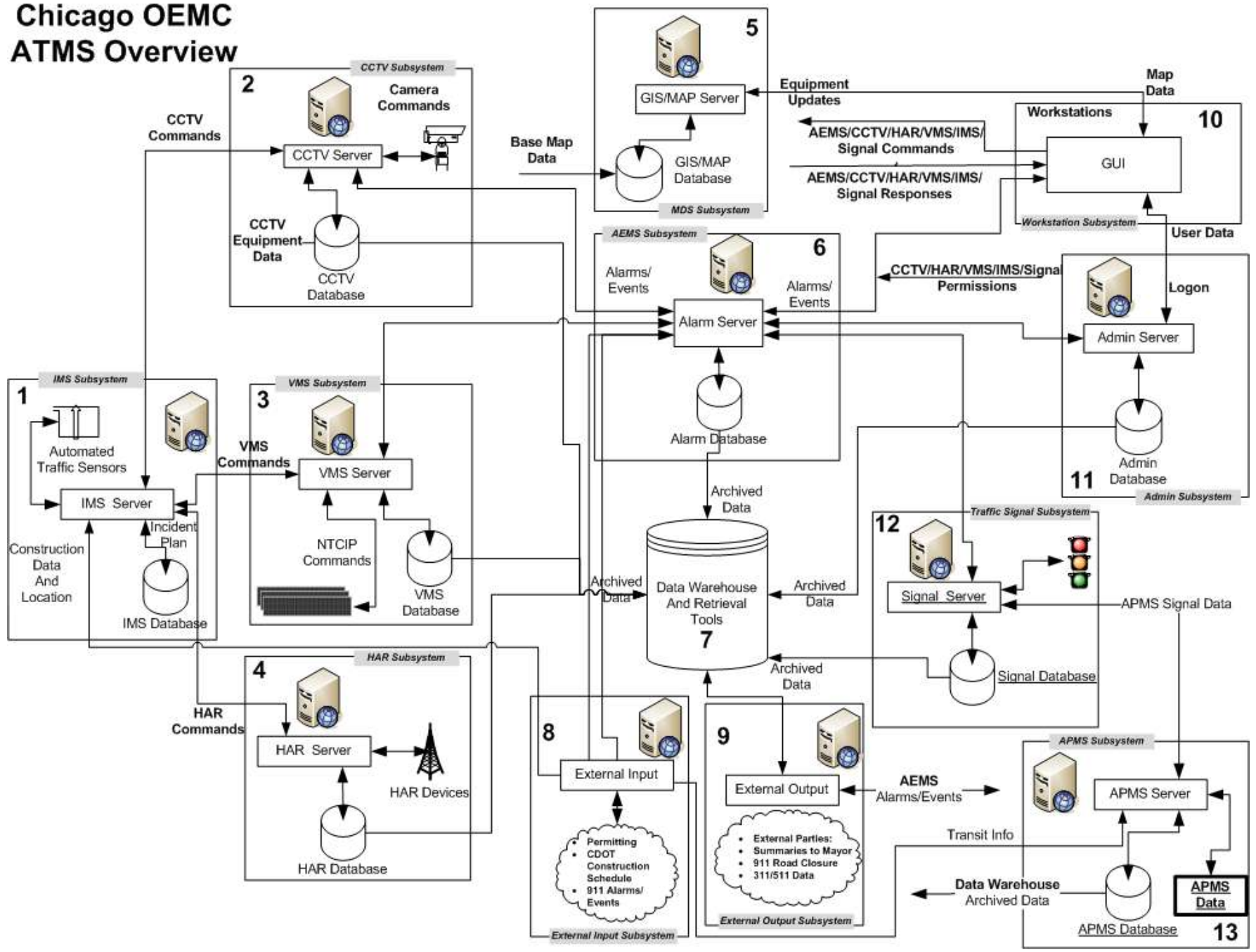

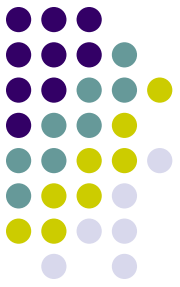

Project:
**Chicago Unified
Command Vehicle**



Project Lead:
**City of Chicago Office of
Emergency Management
and Communications**

Project Team:
**MorganFranklin Corp.
E-One Corp.**

Next steps

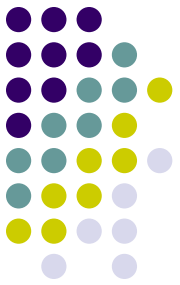

- **Continue system manager approach**
- **Finalize requirements & specifications**
- **RFP for system development and implementation (early 2009)**
- **Build out TMC systems (2009)**
 - Hardware
 - Software
 - Network
 - Staffing
 - Training
- **Test and operate (2009+)**

Thanks,

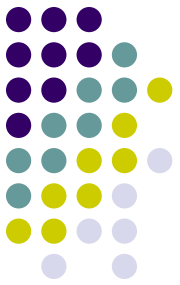

**David Zavattero, Deputy Director
Chicago Office of Emergency Management and
Communications (OEMC)
Traffic Management Authority**

dzavattero@cityofchicago.org