

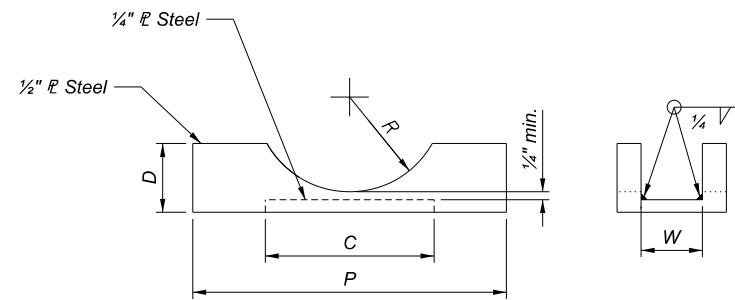

**NOTES:**

1. The design of the Semi-Overhead Sign Support presented on this drawing meets the requirements of the AASHTO LRFD Specifications for Structural Supports for Highway Signs, Luminaires, and Traffic Signals, First Edition 2015 (LRFDLTS-1) and all interim releases prior to the bid date of the project.
2. Dimensions noted as required shall be as indicated on the drawing and shall not be altered.
3. Calculations are required for any modifications to the information shown on this drawing. Modifications shall meet the requirements of LRFDLTS-1 and the design criteria shown in Note 22. Calculations shall be stamped by a Professional Engineer registered in the State of Ohio and shall be submitted for review and approval with the shop drawings.
4. For sign attachment assemblies to be furnished with this support, construction details, and location of handholes, see Standard Construction Drawings (SCDs) TC-22.10 and TC-22.20.
5. For foundation details, see SCD TC-21.21.
6. Steel for round tube arms shall conform to C&MS 730.01.
7. Signs with arms may be adjusted eccentric to the pole; however, a minimum of 2' of sign length shall remain to one side of the pole center line.
8. For modification of pole to support roadway lighting, see SCD HL-10.12.
9. The pole attachment to the base plate shall be welded using a full penetration weld.
10. A minimum of one bolt thread shall remain above the anchor nut.
11. For pole and base plate dimensions, see Sheet 2.
12. The design was based on Fatigue Category II. See Note 22 for additional design criteria.

(cont'd - see Sheet 2)



**CRADLE**

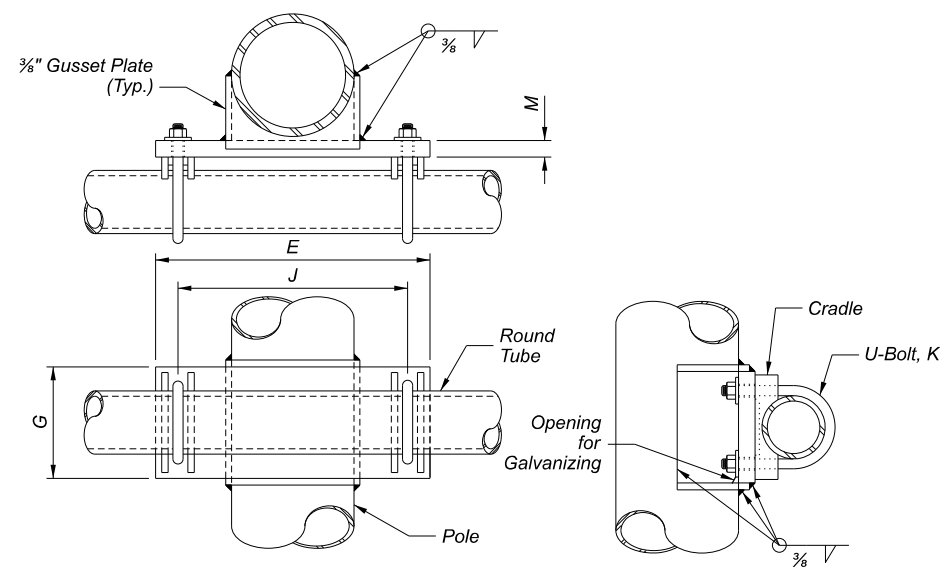
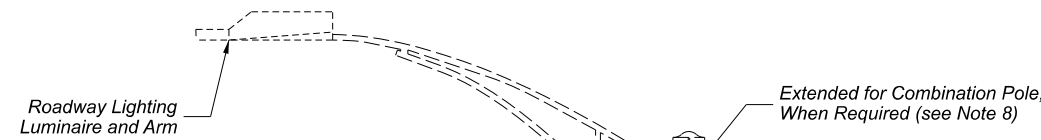

**ROUND ARM ATTACHMENT**

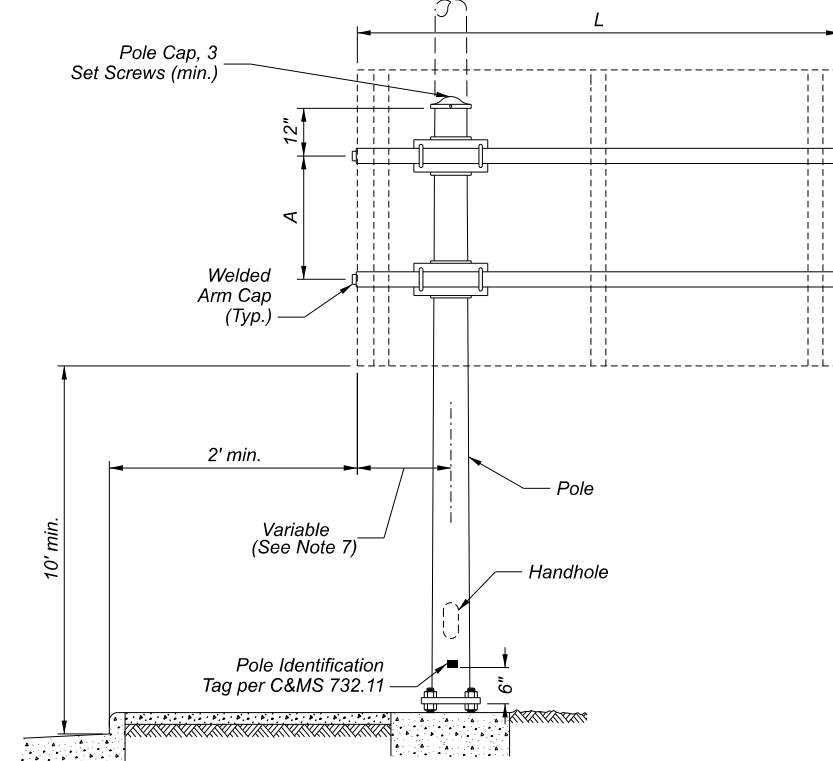

**NOTES:** (cont'd from Sheet 1)

13. Tapered poles shall be one piece assemblies conforming to ASTM A 595 Grade A (minimum yield strength of 55,000 psi) with a constant linear taper of 0.14 inch/foot. See Note 14 for Tube Pole material requirements.
14. All material shall meet the requirements of C&MS 730 with the following limitations:  
  
Steel hardware - Galvanizing - ASTM A 153 (Hot-dipped) (Not ASTM B 695 Class 50)
15. Nuts shall meet the requirements of C&MS 730.08 and shall also meet the requirements of ASTM A 563 Grade DH or A 194 Grade 2H.
16. Flat washers shall meet the requirements of C&MS 730.08 and shall also meet the requirements of ASTM F 436.
17. Anchor bolts shall meet the requirements of C&MS 632, 711.02, 730.02 and 732.11 except that 730.02 shall be modified to require the galvanizing limits to be the full length of the anchor bolts not at least 2 inches beyond the threads.
18. Anchor bolt nuts shall meet the requirements of ASTM A 563 Grade DH or A 194 Grade 2H.
19. Anchor bolt washers shall meet the requirements of ASTM F 436 Type 1 (Hot-dip galvanized) according to ASTM A 153.
20. Holes for high-strength bolts and bearing bolts shall meet the requirements of C&MS 513.19. Modifications to the holes must be approved by the Engineer. Enlarging or slotting holes to match mis-aligned anchor bolts will not be permitted.
21. All welds shall be inspected according to the requirements of C&MS 630.06 and AWS D1.1 Structural Welding Code - Steel. A report of the welding inspection shall be submitted to the ODOT Office of Material Management Structural Welding and Materials Engineer.

22. Design Criteria:

Load Parameters:

Wind Load: 700-year MRI Basix Wind Speed Map, 115 mph Design Wind Speed

Service Life: Infinite per LRFDLTS-1 11.9.3

Service I Wind Velocity: 76 mph per LRFDLTS-1 Table 3.4.1 and Figure 3.8-4b

ADT: Greater than 10,000

Serviceability Parameters:

Rake (Pole Tilt): H/180 (H = pole height)

Horizontal Deflection at Top of Pole: maximum 1.5% of pole height

Slope at Top of Pole: maximum of 0.35 inch/foot (1.67 degrees) per LRFDLTS-1 10.4.2.1

Fatigue Parameters:

Fatigue Category: II

Natural Wind Gust: Include

Truck-Induced Gust: Include

Galloping: Do not include

**LEGEND:**

\* = Required dimension see Note 2

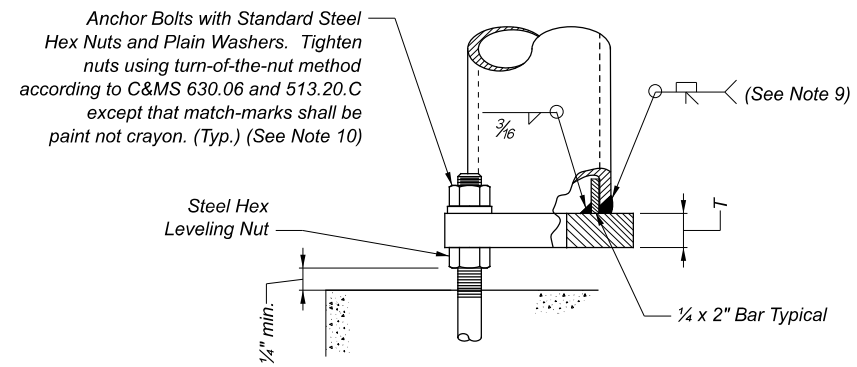

**POLE DETAILS**

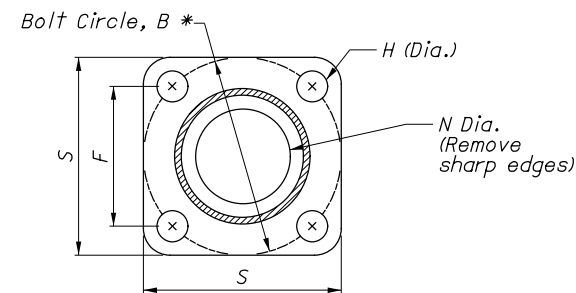

**BASE PLATE**

**THESE DESIGNS USE FULL PENETRATION WELDS AT THE BASE PLATE CONNECTIONS**

ALL DIMENSIONS IN INCHES, UNLESS OTHERWISE NOTED

DESIGN NO.	POLE HEIGHT (FT)	MAXIMUM SIGN AREA (SQ FT)	TAPERED POLE (STANDARD)		TUBE POLE (ALTERNATE)		ARM			ARM ATTACHMENT					CRADLE					ANCHOR BASE					
			BASE DIAMETER	MIN. WALL THICKNESS	DIAMETER	MIN. WALL THICKNESS	ROUND TUBE (NOTE 6)	L MAXIMUM (FT)	A (FT)	E	G	J	K	M	C	D	P	R	W	B*	F	S	T	H	N
2	16.5	100	10	.239	8 3/4	.312	4 1/2 x .237	12	2.5	18	8	16	%	1	4 1/2	1 1/2	6 1/2	2 1/4	1	13 1/2	9 5/16	14 1/4	1 1/2	1 3/4	8 1/2
3	17.5	150	12	.239	10 3/4	.307	5 5/16 x .258	15	3.0	18	8	16	%	1	5 1/2	1 3/4	7 1/2	2 3/4	1	16	11 5/16	17	2	2 1/2	10 1/2