

BEARING DETAIL

* - BEVEL = LONGITUDINAL GRADE x SIN (SKEW ANGLE)
** - BEVEL = LONGITUDINAL GRADE x COS (SKEW ANGLE)

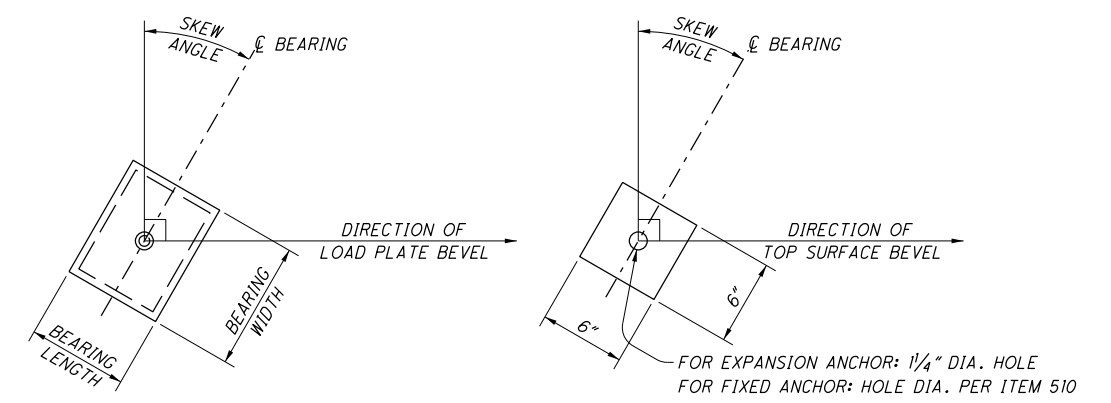

BEARING ORIENTATION

6"x6" PREFORMED FILLER ORIENTATION

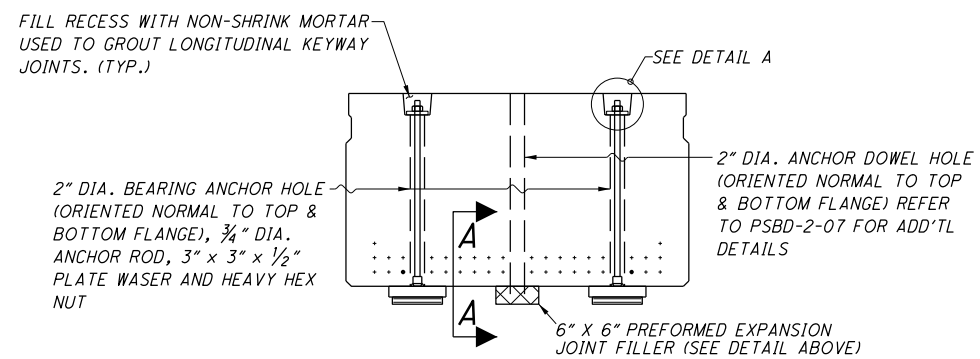

END ELEVATION

(BEAM END WITHOUT NOTCH)

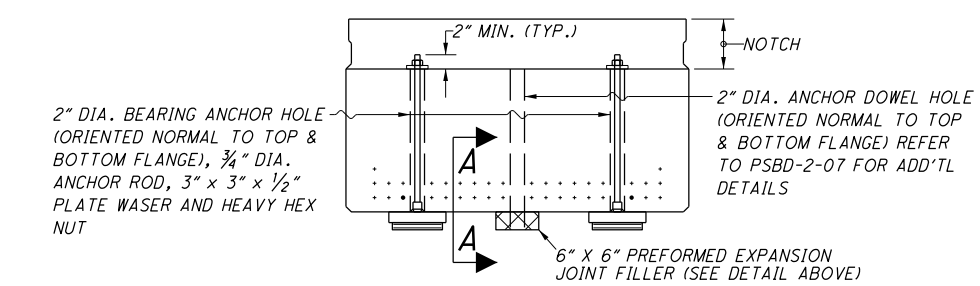

END ELEVATION

(BEAM END WITH NOTCH)

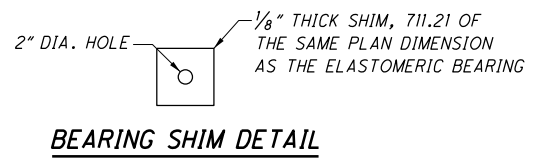

BEARING SHIM DETAIL

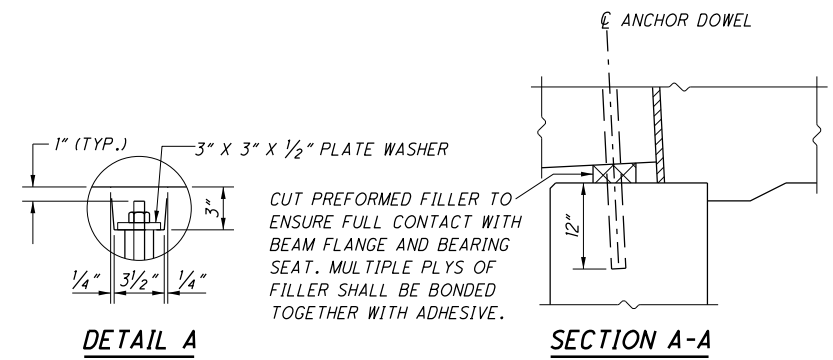

DETAIL A

SECTION A-A

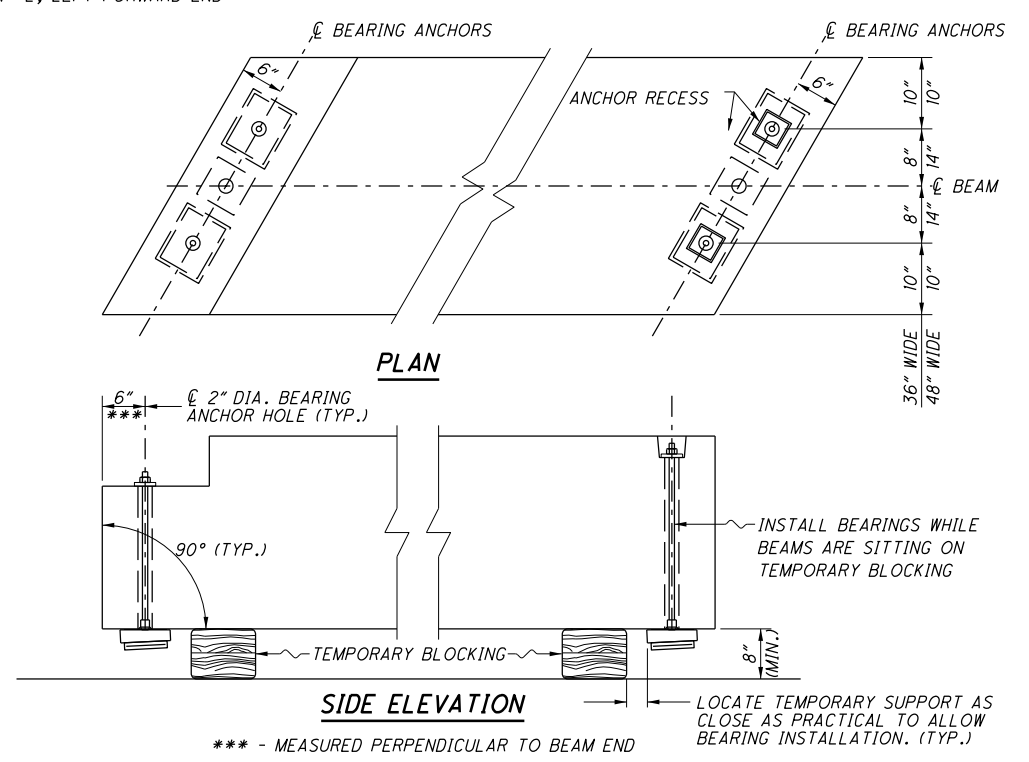

PLAN

SIDE ELEVATION

*** - MEASURED PERPENDICULAR TO BEAM END

NOTES

GENERAL: THE PURPOSE OF THIS STANDARD DRAWING IS TO MINIMIZE BEARING ROTATION CAUSED BY ROADWAY GRADE. THIS DRAWING IS NOT REQUIRED FOR ELASTOMERIC BEARING DESIGNS THAT CAN ACCOMMODATE THE ROADWAY GRADE ROTATION. THE PROJECT PLANS SHALL INCLUDE: LONGITUDINAL GRADE, SKEW ANGLE, BEARING DIMENSIONS, LOAD PLATE DIMENSIONS AND BEAM SIZES.

BOX BEAM BEARINGS SHALL BE DESIGNED FOR FOUR SOURCES OF ROTATION: ROADWAY GRADE; CAMBER; DEAD LOAD; AND LIVE LOAD. THE MAGNITUDE OF EACH SOURCE OF ROTATION MAY BE EQUAL AT EACH END OF THE BEAM; BUT, THE DIRECTION OF EACH SOURCE OF ROTATION MAY BE DIFFERENT. AT THE REAR END OF THE BOX, POSITIVE CAMBER WILL BE COUNTERCLOCKWISE; DEAD & LIVE LOAD WILL BE CLOCKWISE; NEGATIVE GRADE WILL BE CLOCKWISE; POSITIVE GRADE WILL BE COUNTERCLOCKWISE. AT THE FORWARD END OF THE BOX, POSITIVE CAMBER WILL BE CLOCKWISE; DEAD & LIVE LOAD WILL BE COUNTERCLOCKWISE; NEGATIVE GRADE WILL BE CLOCKWISE; POSITIVE GRADE WILL BE COUNTERCLOCKWISE.

DESIGNERS SHOULD ANALYZE THE EFFECT FROM ALL SOURCES OF ROTATION ON THE ELASTOMERIC BEARING DESIGN TO DETERMINE IF THIS STANDARD DRAWING IS REQUIRED.

BEARING INSTALLATION: BEARINGS MAY BE INSTALLED WHILE BEAMS ARE SUPPORTED ON TEMPORARY BLOCKING AS SHOWN HEREIN. TIGHTEN BEARING ANCHOR NUTS SUCH THAT THE GAP AT THE PERIMETER OF THE LOAD PLATE BETWEEN THE BOTTOM OF THE BEAM AND THE LOAD PLATE DOES NOT EXCEED 0.125 INCH AT ANY LOCATION. PROPERLY ALIGN BEARINGS ACCORDING TO MARKINGS.

WELDING: CONTROL WELDING SO THAT THE PLATE TEMPERATURE AT THE ELASTOMER BONDED SURFACE DOES NOT EXCEED 300°F AS DETERMINED BY USE OF PYROMETRIC STICKS OR OTHER TEMPERATURE MONITORING DEVICES. REPAIR GALVANIZED COATING DAMAGED BY WELDING ACCORDING TO 711.02.

LIFTING INSERTS: SHIFT LIFTING INSERTS AS NECESSARY TO CLEAR BEARING ANCHOR HOLES AND RECESS POCKETS BY 1/4" MINIMUM. REFER TO PSBD-2-07 FOR ADDITIONAL INFORMATION.

PREFORMED BEARING PADS: IN ADDITION TO THE PREFORMED BEARING PADS REQUIRED ABOVE EACH LOAD PLATE AS SHOWN HEREIN, SUPPLY PREFORMED BEARING PADS ACCORDING TO PSBD-2-07.

BEARING MARKINGS: PERMANENTLY MARK BOTH SIDES OF EACH LOAD PLATE WITH AN ARROW POINTING TO THE NEAREST BEAM END AS SHOWN IN THE BEARING DETAIL SIDE ELEVATION. PERMANENTLY LABEL EACH END OF THE LOAD PLATE WITH THE BEAM NUMBER, SPAN NUMBER AND LOCATION AS FOLLOWS:
EX. B2/S2/RR - BEAM LINE #2, SPAN #2, RIGHT REAR END
EX. B1/S2/LF - BEAM LINE #1, SPAN #2, LEFT FORWARD END

MATERIAL: FURNISH MATERIAL CONFORMING TO THE FOLLOWING:

LOAD PLATE: ASTM A709, GRADE 50, GALVANIZED ACCORDING TO C&MS 711.02

ELASTOMERIC BEARING: C&MS 711.23

BEARING SHIM: C&MS 711.21

INTERNALLY TREADED, END WELDED STUD: ASTM A 108 (F_y = 50 KSI), GALVANIZE ACCORDING TO C&MS 711.02. THREADS SHALL BE IN ACCORDANCE WITH ANSI B1.1 UNC-2B TO ACCEPT THE 3/4" DIA. THREADED ROD. WELD PER AWS D1.5.

BEARING ANCHOR RODS: 3/4" DIA. ASTM A449 GALVANIZED THREADED RODS. THREADS SHALL BE IN ACCORDANCE WITH ANSI B1.1 UNC-2B.

PLATE WASHER: ASTM A36, GALVANIZED ACCORDING TO C&MS 711.02

NUTS: ACCORDING TO C&MS 711.09.

GROUT: ACCORDING TO PSBD-2-07

PREFORMED FILLER: SHALL BE CORK IN ACCORDANCE WITH AASHTO M153, TYPE II OR SELF EXPANDING CORK IN ACCORDANCE WITH AASHTO M153, TYPE III

MEASUREMENT & PAYMENT:

THE DEPARTMENT WILL INCLUDE THE MORTAR USED FOR THE BEARING ANCHOR RECESS HOLES AND PREFORMED FILLER WITH THE BOX BEAMS FOR PAYMENT.

THE DEPARTMENT WILL PAY FOR ACCEPTED PREFORMED BEARING SHIMS AT THE CONTRACT PRICE AS FOLLOWS:

ITEM 516 EACH 1/8-INCH PREFORMED BEARING PADS

THE DEPARTMENT WILL PAY FOR ACCEPTED BEARING ASSEMBLIES INCLUDING LAMINATED ELASTOMERIC BEARINGS, LOAD PLATE, REBAR COUPLER, THREADED REBAR, HARDWARE, MATERIAL, AND LABOR AT THE CONTRACT PRICE AS FOLLOWS:

ITEM 516 EACH ELASTOMERIC BEARING WITH INTERNAL LAMINATES AND LOAD PLATE