

AASHTO TYPES 2, 3 & 4

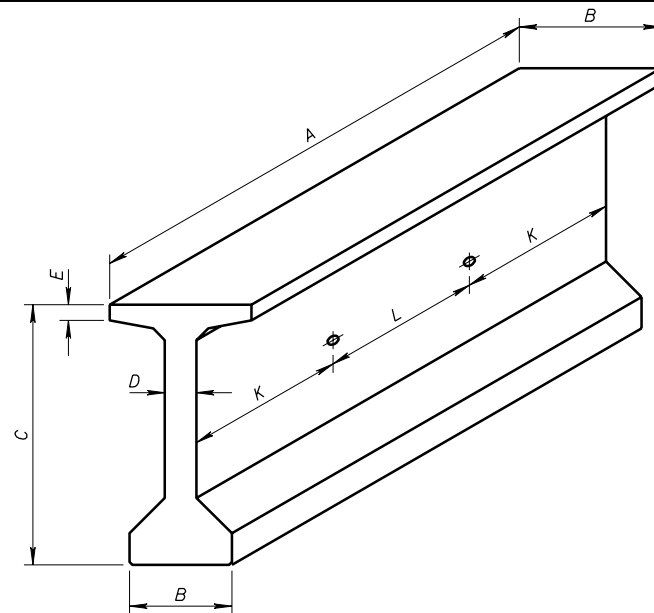

AASHTO MODIFIED TYPE 4 BEAMS

**BEAM DIMENSIONAL TOLERANCES**

	DESCRIPTION	TOLERANCES
A	LENGTH OF BEAM	$\frac{3}{4}$ "
B	WIDTH OF FLANGES INCLUDING FILLETS	$+\frac{3}{8}$ ", $-\frac{1}{4}$ "
C	TOTAL DEPTH	$+\frac{1}{2}$ ", $-\frac{1}{4}$ "
D	WIDTH OF WEB	$+\frac{3}{8}$ ", $-\frac{1}{4}$ "
E	DEPTH OF FLANGES AND DEPTH OF WEB (INCLUDING FILLETS)	$\pm\frac{1}{4}$ "
F	HORIZONTAL ALIGNMENT (DEVIATION FROM A STRAIGHT LINE PARALLEL TO $\phi$ OF MEMBER)	$\pm\frac{1}{8}$ " PER 10' - 0", 1" MAX.
G	CAMBER, DEVIATION FROM DESIGN CAMBER	$\pm\frac{1}{8}$ " PER 10' - 0", $\frac{1}{2}$ " MAX.
H	STIRRUP BARS, PROJECTION ABOVE TOP OF BEAM	$+\frac{1}{4}$ ", $-\frac{3}{4}$ "
I	STRAND POSITION, C.G. OF STRAND GROUP AND INDIVIDUAL STRANDS	$\pm\frac{1}{4}$ "
J	POSITION OF LIFTING DEVICES	$\pm 6$ "
K	SIDE INSERTS ( $\phi$ TO END)	$+\frac{1}{2}$ ", $-0$ "
L	SIDE INSERTS ( $\phi$ TO $\phi$ )	$\pm\frac{1}{2}$ "
M	BEAM ENDS DEVIATION FROM SQUARE, HORIZONTAL	$\pm\frac{1}{4}$ "
N	BEAM ENDS DEVIATION FROM SQUARE, VERTICAL	$\pm\frac{1}{8}$ " PER 12" OF BEAM HEIGHT
P	STIRRUP BARS, LONGITUDINAL SPACING (ANCHORAGE ZONE)	$\pm\frac{1}{4}$ "
Q	STIRRUP BARS, LONGITUDINAL SPACING	$\pm 1$ "

DIMENSIONAL VARIATION IN EXCESS OF THE TOLERANCES SHOWN MAY BE CAUSE FOR REJECTION OF THE MEMBER  
GENERALLY THE DIMENSIONS SHOULD BE WELL WITHIN THE TOLERANCE LIMIT.

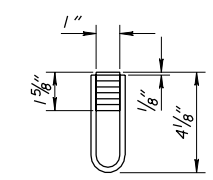

**SINGLE THREADED INSERT**  
(3,000 LB PROOF LOAD)

NOTE - THE GIRDER FABRICATOR MAY USE DOUBLE THREADED INSERTS IN LIEU OF TWO SINGLE INSERTS SPACED AT 4" ON CENTER AT THE CONCRETE INTERMEDIATE DIAPHRAGM LOCATIONS.

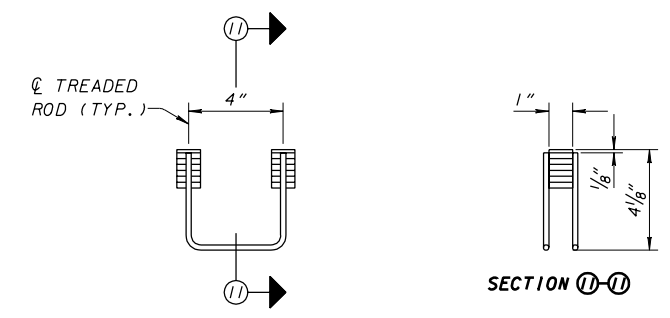

**DOUBLE THREADED INSERT**  
(6,000 LB PROOF LOAD)

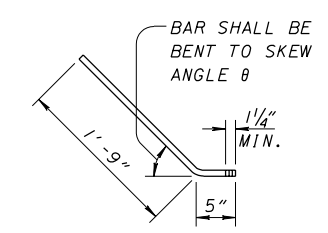

**3/4" DIA. x 2'-2" THREADED ROD**  
SHALL CONFORM TO 709.01, 709.03 OR 709.05 WITH THREADS FORMED PRIOR TO GALVANIZING.

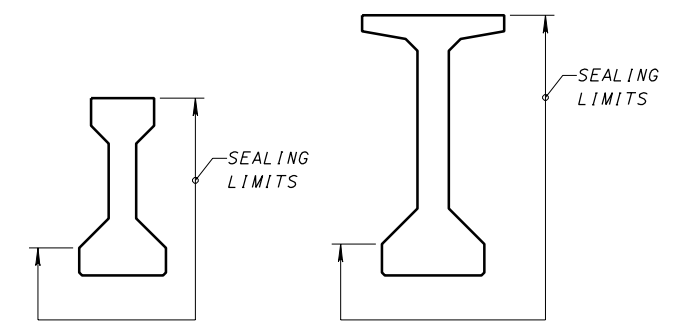

**SEALING OF FASCIA BEAMS**

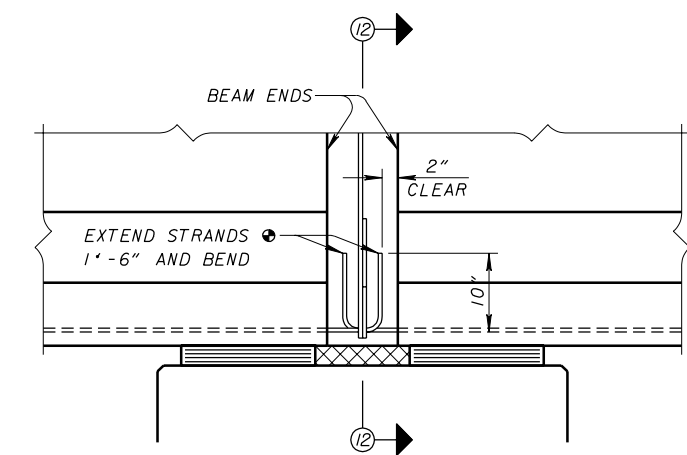

**EXTENDED STRAND DETAIL**

\* - THE NUMBER OF STRANDS TO BE BENT SHALL BE THE LARGER OF ONE HALF THE NUMBER OF ROW 1 STRANDS OR THE NUMBER OF STRANDS SUFFICIENT TO RESIST THE POSITIVE LIVE LOAD MOMENT AT THE PIER. ALTERNATE STRANDS IN ABUTTING BEAMS TO AVOID INTERFERENCE.

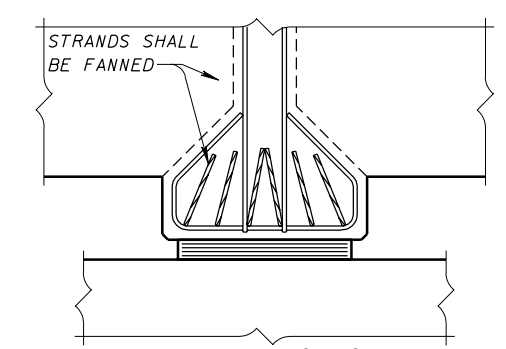

**SECTION 12-12**  
(PARTIAL PIER AND DIAPHRAGM SHOWN)

DESIGN AGENCY  
OFFICE OF  
STRUCTURAL ENGINEERING

---

STATE OF OHIO DEPARTMENT OF TRANSPORTATION  
09-07-99  
DATE

ADMINISTRATOR  
*Brad Fogwell*

---

DESIGNED SAM	CHECKED J.S./WTL	REVISED LMW
DRAWN SAM	PS/D-1-99	

---

REV/ISSUES  
10-20-00  
07-19-02  
07-18-03

---

STANDARD  
**PRESTRESSED CONCRETE I-BEAM**  
BRIDGE DETAILS

---

7 / 8