

END VIEW
(BEARING WITH NO LOAD PLATE)

END VIEW
(BEARING WITH LOAD PLATE)

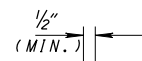

THE 3/4" CHAMFER SHALL BE MOVED TO THE TOP OF THE EMBEDDED SOLE PLATE FOR A LENGTH OF 1'-8" MEASURED FROM THE END OF THE BEAM.
TYPICAL LOCATION OF CHAMFER.
STEEL LOAD PLATE

DETAIL B

STEEL LOAD PLATES: A LAMINATED ELASTOMERIC BEARING WITHOUT A LOAD PLATE SHOULD BE THE FIRST OPTION UNLESS ROTATIONAL AND/OR GRADE REQUIREMENTS DICTATE THE USE OF A LOAD PLATE. A VULCANIZED BEVELED LOAD PLATE IS REQUIRED WHEN THE ROTATIONAL CAPACITY OF A BEARING IS EXCEEDED UNDER ANY LOADING CONDITION. WHEN A LOAD PLATE IS REQUIRED, THE FABRICATOR SHALL INSTALL THE EMBEDDED SOLE PLATE TO ALLOW FOR FIELD INSTALLATION OF THE BEARING. DURING FIELD WELDING, CONTROL THE TEMPERATURE AT THE ELASTOMER BONDED SURFACE TO A MAXIMUM OF 300° F AS DETERMINED BY THE USE OF PYROMETRIC STICKS OR OTHER TEMPERATURE MONITORING DEVICES.

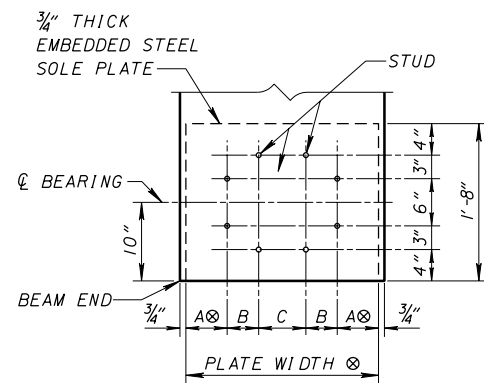

SECTION 2-2
(BEARING AND LOAD PLATE NOT SHOWN)

BOTTOM FLANGE WIDTH	PLATE WIDTH	A	B	C
1'-6"	1'-4 1/2"	3/4"	2"	6"
1'-10"	1'-8 1/2"	4/4"	4"	4"
2'-2"	2'-0 1/2"	5/4"	4"	6"

NOTE - END WELDED STUDS MAY BE MOVED SLIGHTLY IN ORDER TO AVOID REINFORCING STEEL AND PRESTRESSING STRANDS.

⊗ - IN ORDER TO ALLOW FOR FIT-UP, THE PLATE WIDTH MAY BE DECREASED BY 3/8". DIMENSION "A" SHALL BE CORRECTED ACCORDINGLY.

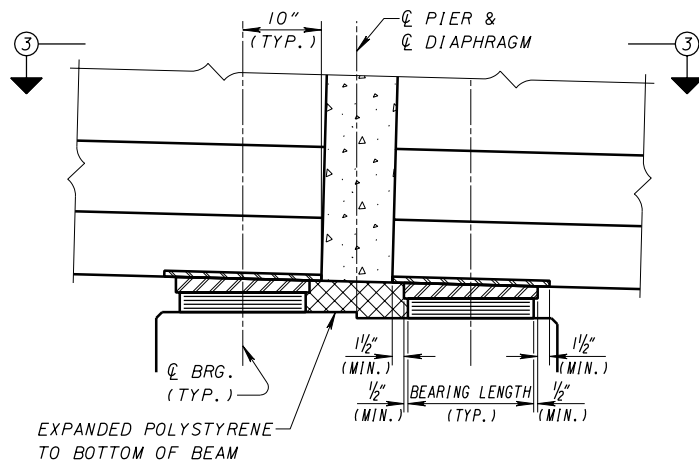

EXPANSION PIER DETAIL
(BEARING WITH LOAD PLATE)

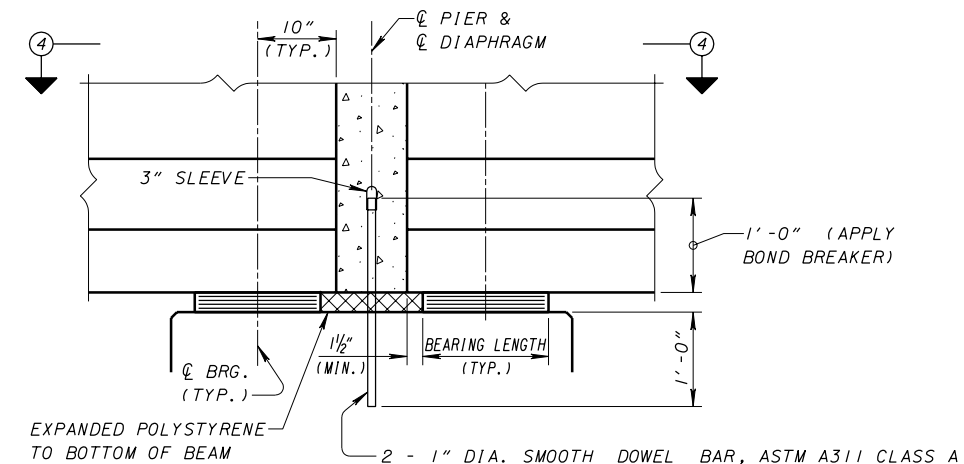

FIXED PIER DETAIL
(BEARING WITH NO LOAD PLATE)

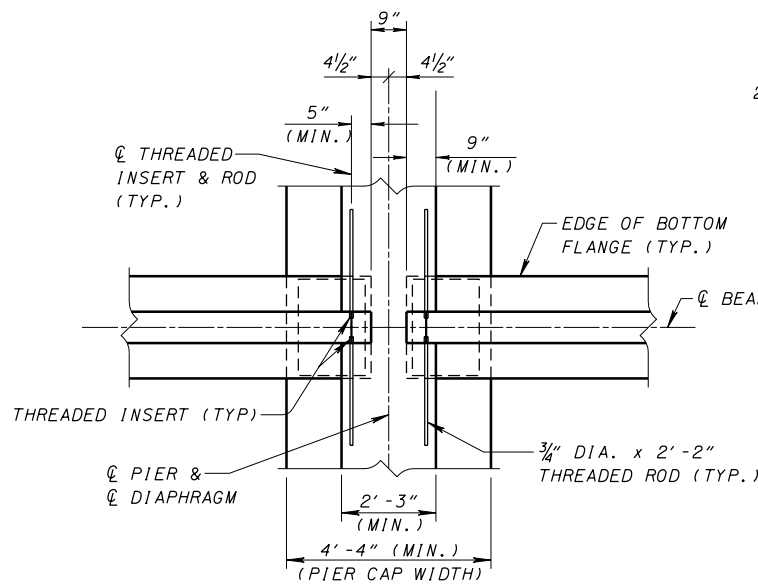

VIEW 3-3
(NO SKEW)

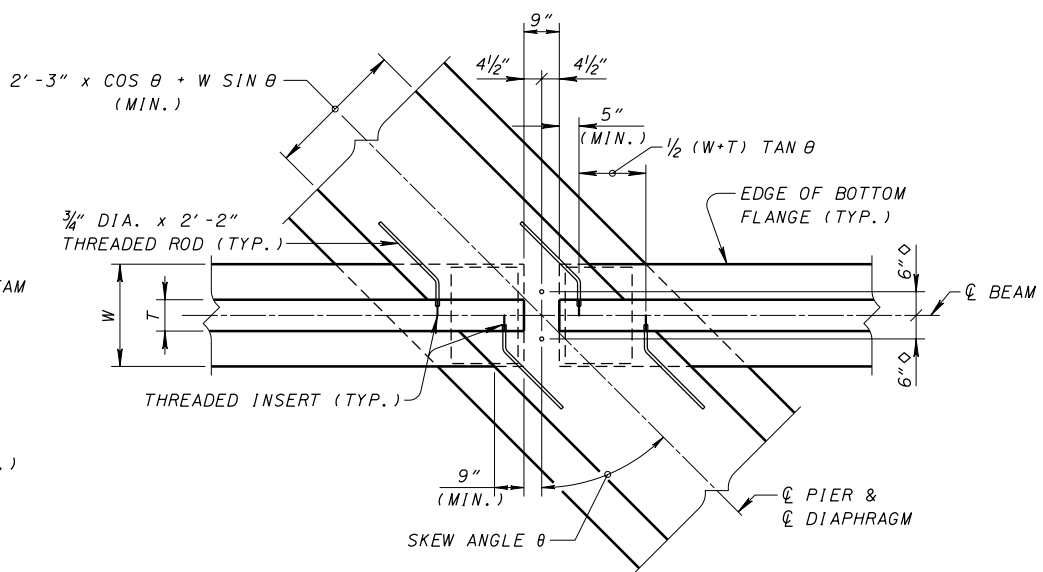

VIEW 4-4
(AT SKEWED PIER)

◇ - MEASURED TO CENTER OF 1" DIA. SMOOTH DOWEL BARS. DOWEL BARS SHALL BE OMITTED AT EXPANSION PIERS.
W = WIDTH OF BOTTOM FLANGE
T = THICKNESS OF WEB

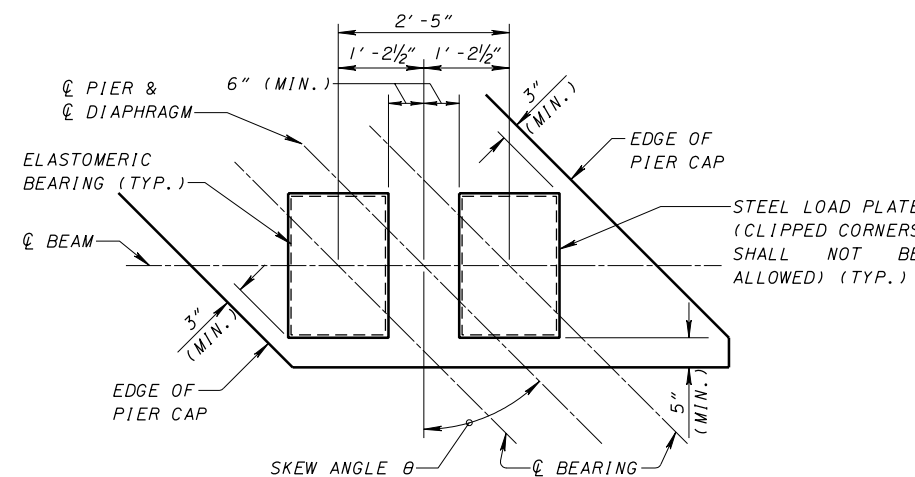

BEARING ORIENTATION AT PIERS
(BEAM NOT SHOWN)

SEE SHEET 5/8 FOR PIER DIAPHRAGM DETAILS.

SEE SHEET 7/8 FOR THREADED INSERT AND ROD DETAILS.