

PARTIAL PLAN OF BEAM CONNECTION OVER PIER

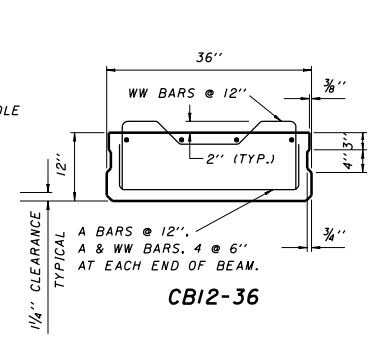

CB12-36

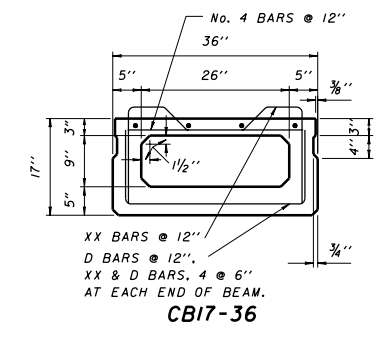

CB17-36

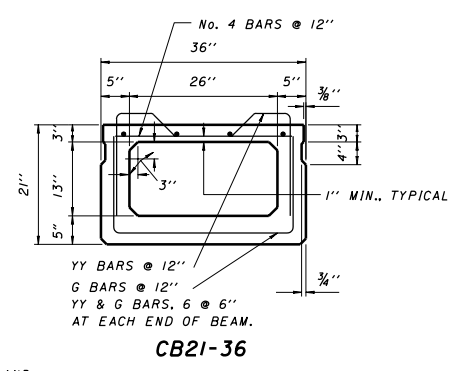

CB21-36

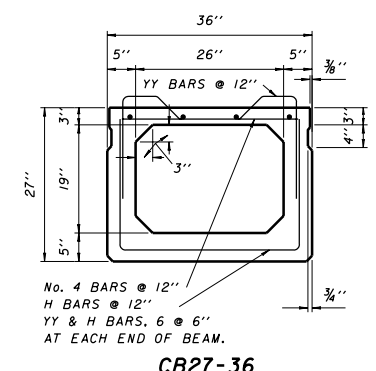

CB27-36

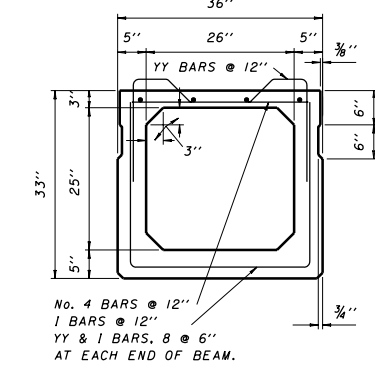

CB33-36

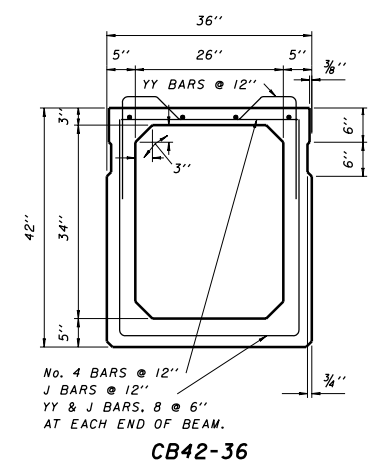

CB42-36

36" WIDE COMPOSITE BEAMS

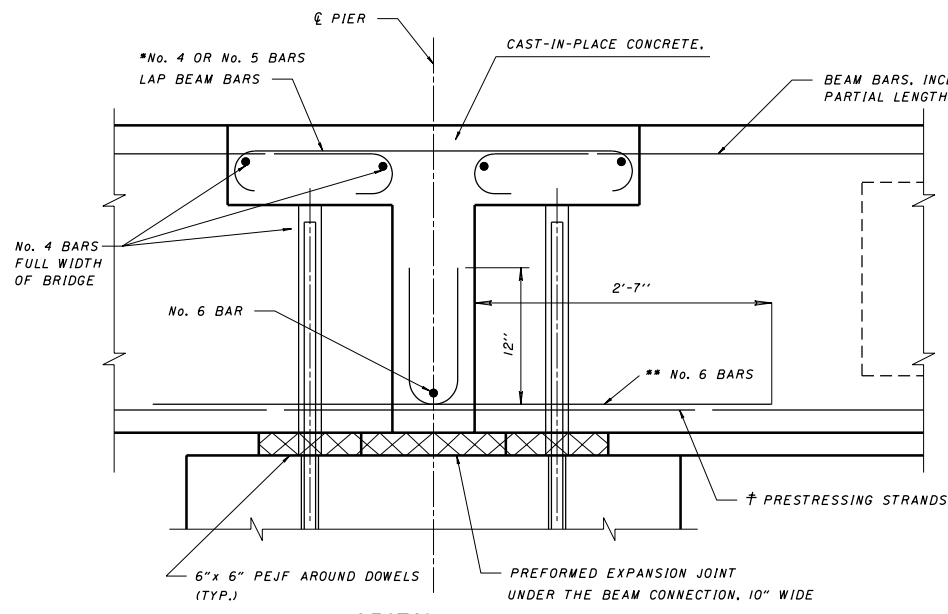

SECTION A-A

		SECTION PROPERTIES					
		48" WIDE COMPOSITE BOX BEAM					
		CB12-48	CB17-48	CB21-48	CB27-48	CB33-48	CB42-48
BEAM ONLY	A <sub>b</sub>	567.8	484.4	536.4	583.9	638.5	728.6
	I <sub>b</sub>	6,833	16,749	29,272	55,814	92,534	169,413
	Y <sub>b</sub>	5.98	7.94	9.77	12.18	14.86	19.02
	Z <sub>t</sub>	1,135	1,849	2,607	3,766	5,101	7,372
COMPOSITE SECTION	Z <sub>b</sub>	1,143	2,109	2,996	4,582	6,227	8,907
	I <sub>c</sub>	18,685	37,233	58,857	103,738	162,001	278,449
	Y <sub>c</sub>	8.34	11.52	13.73	16.87	20.10	24.87
	Z <sub>t</sub>	5,102	6,791	8,091	10,245	12,555	16,254
Z <sub>b</sub>	2,241	3,233	4,288	6,148	8,061	11,220	

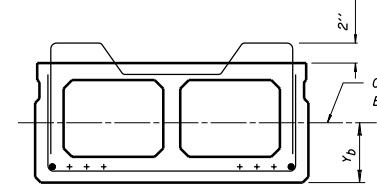

36" OR 48" WIDE COMPOSITE BEAM

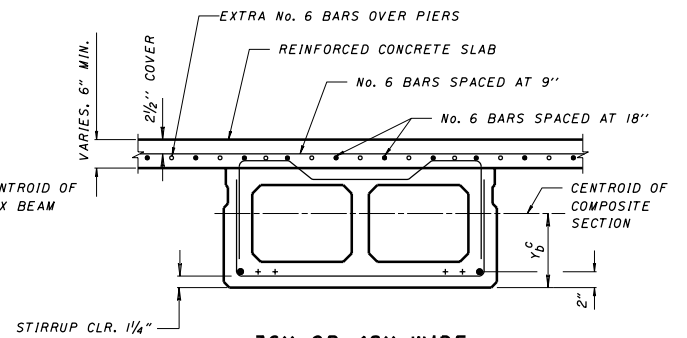

36" OR 48" WIDE COMPOSITE BEAM WITH SLAB

		SECTION PROPERTIES					
		36" WIDE COMPOSITE BOX BEAM					
		CB12-36	CB17-36	CB21-36	CB27-36	CB33-36	CB42-36
BEAM ONLY	A <sub>b</sub>	423.9	374.4	427.9	487.9	542.6	632.6
	I <sub>b</sub>	5,105	12,596	22,529	43,595	73,199	136,202
	Y <sub>b</sub>	5.97	7.81	9.65	12.39	15.12	19.36
	Z <sub>t</sub>	847	1,370	1,984	2,984	4,095	6,017
COMPOSITE SECTION	Z <sub>b</sub>	855	1,614	2,335	3,518	4,840	7,034
	I <sub>c</sub>	14,003	28,468	45,491	79,672	125,553	218,378
	Y <sub>c</sub>	8.34	11.35	13.47	16.67	19.82	24.51
	Z <sub>t</sub>	3,823	5,035	6,039	7,713	9,529	12,483
Z <sub>b</sub>	1,680	2,509	3,378	4,779	6,333	8,911	

NOTE: REINFORCING BAR DATA AND NOTES ARE SHOWN ON SHEET 3 OF 4.

SECTION PROPERTIES FOR COMPOSITE SECTIONS ARE COMPUTED WITH A SLAB THICKNESS OF 5". TOTAL THICKNESS OF SLAB IS 6" WHICH INCLUDES 1" MONOLITHIC WEARING SURFACE.

$E_{slab} = 0.90 E_{beam}$

- \* LAP BARS SAME SIZE AND NUMBER AS BEAM BARS. HOOKS MAY BE ROTATED FROM THE VERTICAL POSITION TO PROVIDE THE REQUIRED CLEARANCE.
- \*\* PROVIDE 6 No. 6 BARS EACH BEAM END IN 48" WIDE BEAMS AND 4 No. 6 BARS EACH BEAM END IN 36" WIDE BEAMS. No. 6 BARS SHALL BE LOCATED ON TOP OF STIRRUPS AND SHALL BE UNIFORMLY SPACED ACROSS THE BEAM.
- † AT THE FABRICATOR'S OPTION, STRANDS MAY BE EXTENDED AND BENT UP IN LIEU OF No. 6 BARS. 48" WIDE BEAMS WITH A TOTAL OF 12 OR MORE STRANDS SHALL HAVE A MINIMUM OF 6 STRANDS BENT UP. 48" WIDE BEAMS WITH LESS THAN 12 STRANDS TOTAL SHALL HAVE APPROXIMATELY ONE HALF OF THE TOTAL NUMBER OF STRANDS BENT UP. 36" WIDE BEAMS WITH A TOTAL OF 8 OR MORE STRANDS SHALL HAVE A MINIMUM OF 4 STRANDS BENT UP. 36" WIDE BEAMS WITH LESS THAN 8 STRANDS TOTAL SHALL HAVE APPROXIMATELY ONE HALF OF THE TOTAL NUMBER OF STRANDS BENT UP.

NOTE: THE PRESTRESSING STRANDS WHICH ARE BENT UP SHALL BE STAGGERED IN ABUTTING BEAM ENDS TO AVOID INTERFERENCE.