

REFER TO RAILING STANDARD BRIDGE DRAWINGS FOR ADDITIONAL RAILING DETAILS. REINFORCEMENT NOT SHOWN.

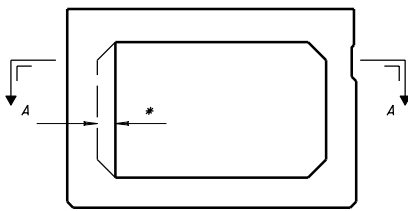

SECTION SHOWING WALL THICKENING AT RAILING ANCHORS

GENERAL NOTES:

- GENERAL:** THIS STANDARD DRAWING PROVIDES DESIGN AND GENERAL CONSTRUCTION DETAILS FOR PRESTRESSED CONCRETE BOX BEAM BRIDGES. THE DETAILS IN THIS STANDARD ARE APPLICABLE TO STRUCTURES WITH SKEW ANGLES OF 30° OR LESS. AS A MINIMUM, THE PROJECT PLANS FOR EACH STRUCTURE SHALL INCLUDE THE FOLLOWING DETAILS:
1. THE DESIGNER SHALL CHOOSE A 28-DAY CONCRETE STRENGTH BETWEEN 5500 PSI AND 7000 PSI; A RELEASE STRENGTH BETWEEN 4000 PSI AND 5000 PSI; AND A NOMINAL STRAND AREA OF 0.153 IN² OR 0.167 IN². THE DESIGNER SHALL USE THESE VALUES IN THE DESIGN AND LIST THESE VALUES IN THE STRUCTURE GENERAL NOTES.
 2. A BEAM LAYOUT PLAN SHOWING: SPAN LENGTH; BEAM LENGTH; SKEW ANGLE; FIXED AND EXPANSION ENDS OF BEAMS; LOCATION OF ANCHOR DOWELS; SIZE, LOCATION AND HARDNESS OF ELASTOMERIC BEARING PADS; LOCATION OF DIAPHRAGM CENTERLINES; AND LOCATIONS OF RAILING POSTS.
 3. A TRANSVERSE CROSS SECTION THROUGH THE DECK.
 4. A BEAM ELEVATION/LONGITUDINAL CROSS SECTION SHOWING THE STIRRUP SPACING AND VARIABLE TOPPING THICKNESS IN SUFFICIENT DETAIL.
 5. A CROSS SECTION OF THE BEAM SHOWING BEAM TYPE AND SIZE; SIZE, NUMBER, STRENGTH AND LOCATION OF STRANDS; DEBONDED STRAND REQUIREMENTS; ALL REINFORCING STEEL DETAILS; AND THE DESIGN DATA.
 6. EXPANSION JOINT DETAILS.
 7. ALL PLAN QUANTITY PAY ITEMS REQUIRED TO PROPERLY COVER THE COST OF FABRICATION, ERECTION AND CONSTRUCTION OF THE BEAMS.
 8. DETAILS OF ABUTMENTS AND PIERS.
 9. SEALING OF CONCRETE SURFACE LIMITS AND SEALER TYPE.
 10. ALL OTHER DETAILS AND INFORMATION NECESSARY TO COMPLETE THE PLANS.

ANCHOR DOWELS SHALL BE 1" DIAMETER SMOOTH STEEL RODS RODS CONFORMING TO ASTM A311, GRADE 1018. THE DESIGNER SHALL INDICATE ON THE PLANS WHICH BEAM ENDS ARE TO BE ANCHORED AND IF THE ANCHOR IS FIXED OR EXPANSION. LOCATE THE ANCHOR DOWEL HOLES AND PRESTRESSING STRANDS TO AVOID MUTUAL INTERFERENCE. THE LATERAL SPACING OF THE HOLES IN THE BEAM SHALL BE SUCH THAT THE ANCHOR DOWELS CLEAR THE ELASTOMERIC BEARING AND ARE AS CLOSE TO THE CENTERLINE OF BEAM AS POSSIBLE.

AFTER TENSIONING OF THE TRANSVERSE TIE RODS, DRILL 1/16" MINIMUM DIAMETER DOWEL HOLES FOR FIXED DOWELS OR 1/4" MINIMUM DIAMETER HOLES FOR EXPANSION DOWELS INTO THE ABUTMENT OR PIER SEAT. CLEAN AND DRY DOWEL HOLES AND INSTALL DOWELS.

ELASTOMERIC BEARINGS: FOUR ELASTOMERIC BEARINGS ARE REQUIRED PER BEAM. POSITION AS SHOWN ON SHEET 4 OF 4.

PREFORMED BEARING PADS: WHERE THE ENGINEER DEEMS THAT SHIMS ARE REQUIRED, INSTALL PREFORMED BEARING PADS, 7/16" THICK AND OF THE SAME PLAN DIMENSIONS AS THE ELASTOMERIC BEARINGS.

BEAM ENDS: APPLY ITEM 512 TYPE B WATERPROOFING TO THE BOX BEAM ENDS THAT ARE NOT COMPLETELY ENCASED IN CONCRETE.

NOTCHES: PROVIDE NOTCHES IN THE BEAM ENDS AT ABUTMENTS TO ACCOMMODATE EXPANSION JOINT ANCHORAGES AS SHOWN ON STANDARD BRIDGE DRAWINGS EXJ-3-82 AND EXJ-5-93 AND AT PIERS TO ACCOMMODATE CONTINUITY AS SHOWN ON SHEET 4 OF 4.

DRIP GROOVES ON THE UNDERSIDE OF THE FASCIA BEAM ARE NOT PERMITTED.

SURFACE PREPARATION FOR MORTAR: THE FABRICATOR SHALL SANDBLAST THE KEYWAY SURFACES WITHIN FOUR DAYS OF SHIPMENT TO THE PROJECT SITE. THE SANDBLASTING SHALL YIELD A VISUAL APPEARANCE AND TEXTURE EQUAL OR ROUGHER THAN 100 GRIT SANDPAPER OVER THE ENTIRE KEYWAY SURFACE. WHEN STAINS ARE VISIBLE BEFORE BLASTING THE CONCRETE, USE A DEGREASER TO ENSURE REMOVAL OF GREASE, OILS AND OTHER SIMILAR CONTAMINANTS. THE DEGREASER SHALL BE WATER SOLUBLE SO IT CAN BE REMOVED BEFORE THE BLASTING BEGINS. BEFORE MORTARING, REMOVE ALL DIRT, DUST, GREASE, OIL AND OTHER FOREIGN MATERIAL FROM THE SURFACES USING A HIGH PRESSURE WASH OF AT LEAST 1000 PSI AT A DELIVERY RATE OF AT LEAST 4 GAL./MIN.

MORTAR: MORTAR OR GROUT FOR TIE ROD RECESSES, ANCHOR DOWEL HOLES AND KEYWAYS BETWEEN PRESTRESSED CONCRETE BOX BEAMS, SHALL BE A NON-SHRINK TYPE AS DESCRIBED IN THE ALTERNATES BELOW. DURING THE GROUTING OPERATION, PREPARE AT LEAST THREE, 3" DIAMETER BY 6" LONG TEST CYLINDERS OF THE GROUTING MATERIAL. SUBMIT THE CYLINDERS TO THE LABORATORY TO DETERMINE THE MINIMUM COMPRESSIVE STRENGTH OF THE GROUT.

ALTERNATE 1 - OPEN TO TRAFFIC LATER THAN 7 DAYS AFTER GROUTING:

FURNISH MORTAR CONFORMING TO 705.22 OR TO PROPOSAL NOTE FOR HIGH EARLY STRENGTH KEYWAY GROUT. AFTER THE TIE RODS ARE TIGHTENED, PREPARE, PLACE AND CURE THE MORTAR ACCORDING TO THE MANUFACTURER'S SPECIFICATIONS. PLACE MORTAR IN A MANNER THAT ENSURES COMPLETE AND SOLID FILLING. THE MINIMUM STRENGTH OF THE MORTAR SHALL BE 5000 PSI BEFORE CONSTRUCTION OR VEHICULAR TRAFFIC IS ALLOWED ON THE BEAMS.

ALTERNATE 2 - PART WIDTH CONSTRUCTION OR OPEN TO TRAFFIC WITHIN 7 DAYS AFTER GROUTING:

FURNISH MORTAR CONFORMING TO PROPOSAL NOTE FOR HIGH EARLY STRENGTH GROUT. AFTER THE TIE RODS ARE TIGHTENED, PREPARE, PLACE AND CURE THE MORTAR ACCORDING TO THE MANUFACTURER'S SPECIFICATIONS. PLACE MORTAR IN A MANNER THAT ENSURES COMPLETE AND SOLID FILLING. THE MINIMUM STRENGTH OF THE MORTAR SHALL BE 5000 PSI BEFORE CONSTRUCTION OR VEHICULAR TRAFFIC IS ALLOWED ON THE BEAMS.

COMPOSITE BRIDGES:

1. SURFACE PREPARATION: THOROUGHLY CLEAN THE TOP SURFACE OF THE BEAMS OF ALL DIRT, DUST AND OTHER FOREIGN MATERIALS WITH WATER, AIR UNDER PRESSURE OR ANY OTHER METHOD THAT PRODUCES SATISFACTORY RESULTS. THOROUGHLY DRENCH THE SURFACE WITH CLEAN WATER. BEFORE PLACING THE CONCRETE, ALLOW THE SURFACE TO DRY TO A DAMP CONDITION.
2. SLAB PLACEMENT: COMPOSITE SLAB POURS ON MULTISPAN SPAN BRIDGES SHALL BE AS LONG AS PRACTICAL. IF NECESSARY, PLACE CONSTRUCTION JOINTS NEAR MIDSPAN, PERPENDICULAR TO THE CENTERLINE OF THE ROADWAY. WHEN STRUCTURAL EXPANSION JOINTS ARE LOCATED AT THE PIERS, PLACE COMPOSITE SLAB BETWEEN THESE JOINTS WITHOUT ADDITIONAL CONSTRUCTION JOINTS EXCEPT AS NOTED IN 511.

BASIS OF PAYMENT: ALL COSTS ASSOCIATED WITH FURNISHING AND INSTALLING THE KEYWAY GROUT, THE ANCHOR DOWELS AND THE PREFORMED EXPANSION JOINT FILLER BETWEEN THE BEARINGS, IS CONSIDERED INCIDENTAL TO THE BOX BEAMS.

THE DEPARTMENT WILL PAY FOR FURNISHING AND INSTALLING TYPE B WATERPROOFING SEPARATELY.

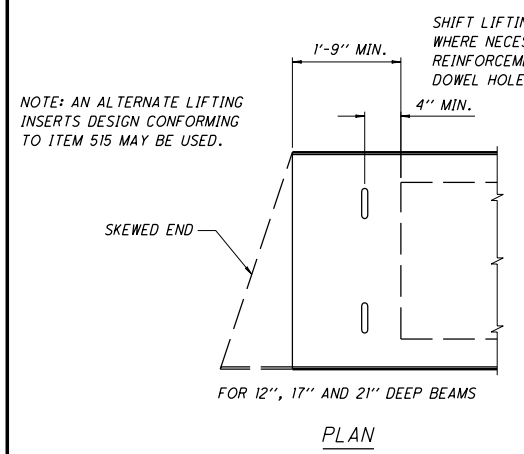

PLAN

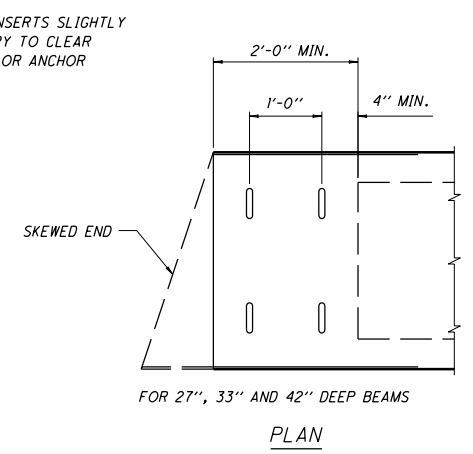

PLAN

BEAM LIFTING INSERTS AT PIER

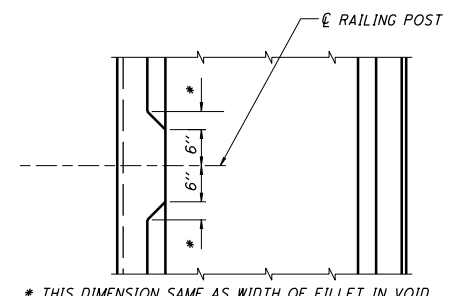

SECTION A-A

* THIS DIMENSION SAME AS WIDTH OF FILLET IN VOID.

DESIGN STRESSES:

PRESTRESSED CONCRETE - F'C = * (28-DAY)

F'CI = ** (RELEASE)

CAST-IN-PLACE CONCRETE - F'C = 4500 PSI

REINFORCING STEEL - MIN. YIELD STRENGTH = 60,000 PSI. ALL REINFORCING STEEL IN THE COMPOSITE SLAB AND BARS PROJECTING FROM THE PRESTRESSED BOX BEAMS SHALL CONFORM TO 709.00.

PRESTRESSING STRAND - FURNISH MATERIAL CONFORMING TO 711.27 (ASTM A416), GRADE 270, LOW RELAXATION, UNCOATED, SEVEN WIRE STRAND. STRANDS SHALL BE 0.5 INCH DIAMETER WITH A TOTAL CROSS-SECTIONAL AREA OF EITHER 0.153 IN² OR 0.167 IN² ***

* - THE DESIGNER SHALL SPECIFY A 28-DAY COMPRESSIVE STRENGTH IN THE RANGE OF 5500 PSI MINIMUM TO 7000 PSI MAXIMUM AND LIST THE VALUE IN THE STRUCTURE'S GENERAL NOTES.

** - THE DESIGNER SHALL SPECIFY A RELEASE STRENGTH IN THE RANGE OF 4000 PSI MINIMUM TO 5000 PSI MAXIMUM AND LIST THE VALUE IN THE STRUCTURE'S GENERAL NOTES.

*** - THE DESIGNER SHALL SPECIFY THE STRAND AREA IN THE STRUCTURE'S GENERAL NOTES.

TRANSVERSE TIE RODS SHALL BE 1" DIAMETER STEEL RODS CONFORMING TO ASTM A311, GRADE 1018, AND THREADED AT EACH END. PROVIDE A NUT AND WASHER AT EACH END. THREADS MAY BE CUT OR ROLLED. IF ROLLED THREADS ARE USED, THE MINIMUM DIAMETER AT THE ROOT OF THE THREADS SHALL BE 0.83". INSTALL AND TORQUE RODS TO APPROXIMATELY 250 FT-LBS. AFTER TIGHTENING, FILL THE RECESSES IN THE FASCIA BEAMS WITH NON SHRINK MORTAR OF THE SAME COLOR AS THE BEAM. TIE NO MORE THAN THREE BEAMS TOGETHER WITH ONE TRANSVERSE TIE ROD.

GALVANIZING: GALVANIZE ANCHOR DOWEL BARS, INSERTS, TIE RODS, NUTS AND WASHERS ACCORDING TO 711.02.

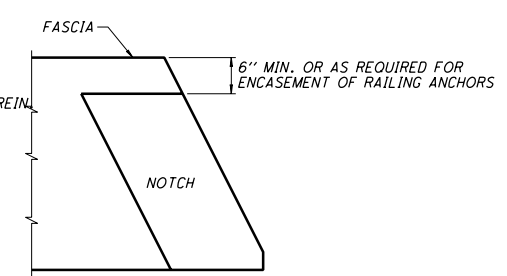

PLAN-FASCIA BEAM WITH NOTCH

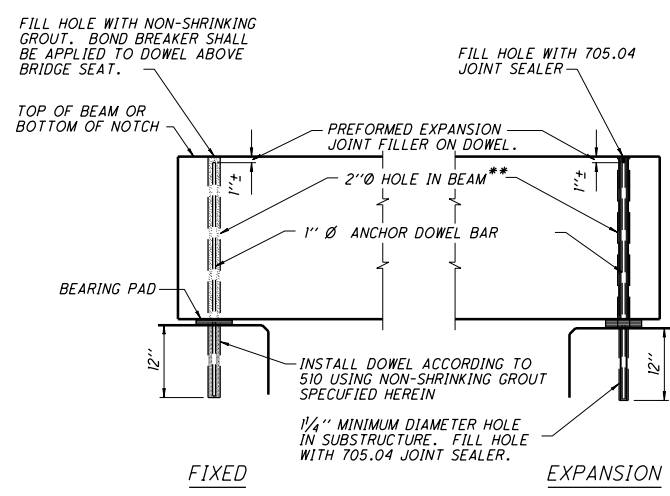

FIXED

EXPANSION

DOWEL CLEARS ELASTOMERIC BEARING

END VIEW

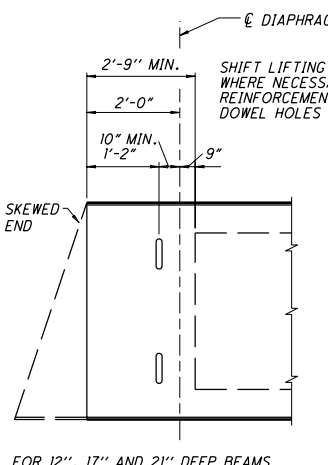

PLAN

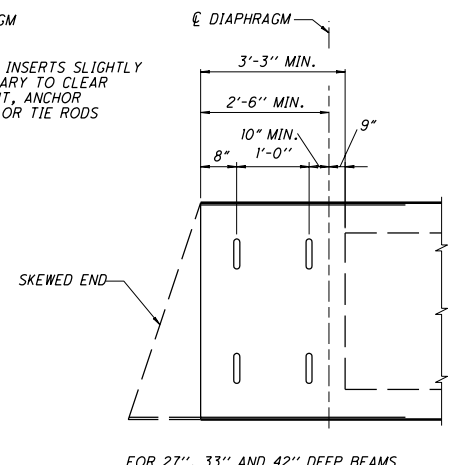

PLAN

BEAM LIFTING INSERTS AT ABUTMENT

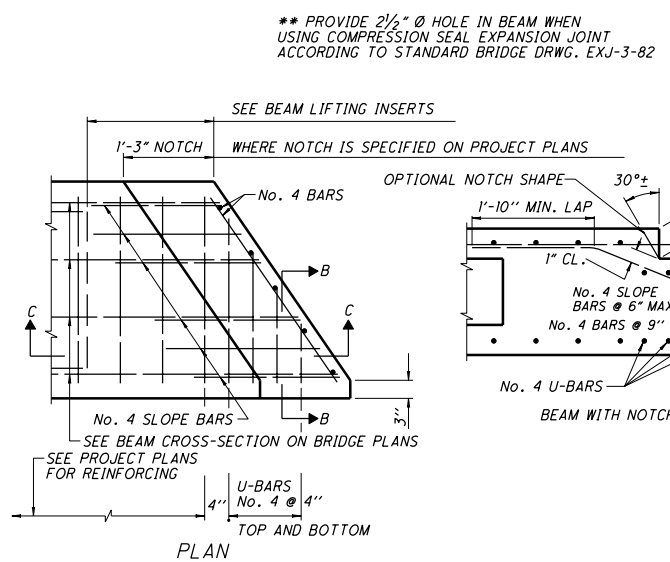

PLAN

ANCHOR DOWELS

SECTION C-C

DETAILS AND REINFORCEMENT OF BEAM ENDS

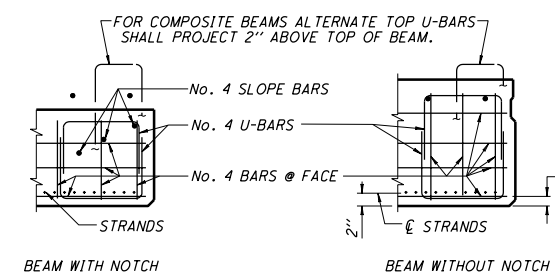

BEAM WITH NOTCH

BEAM WITHOUT NOTCH

SECTION B-B

NOTE: THE FABRICATOR'S SHOP DRAWINGS SHALL SHOW COMPLETE DETAILS OF THE BEAM REINFORCING.