

END VIEW
(BEARING WITH NO LOAD PLATE)

END VIEW
(BEARING WITH LOAD PLATE)

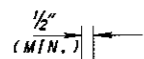

THE $\frac{3}{4}$ " CHAMFER SHALL BE MOVED TO THE TOP OF THE EMBEDDED SOLE PLATE FOR A LENGTH OF 1'-8" MEASURED FROM THE END OF THE BEAM.
TYPICAL LOCATION OF CHAMFER.
STEEL LOAD PLATE

DETAIL B

STEEL LOAD PLATES: A LAMINATED ELASTOMERIC BEARING WITHOUT A LOAD PLATE SHOULD BE THE FIRST OPTION UNLESS ROTATIONAL AND GRADE REQUIREMENTS DEMAND THE USE OF A LOAD PLATE. A VULCANIZED BEVELED LOAD PLATE IS REQUIRED WHEN THE INCLINATION OF THE UNDERSIDE OF THE GIRDER, UNDER FULL UNFACTORED DEAD LOAD, EXCEEDS 0.01 RADIAN. THE DESIGN PLANS SHALL REQUIRE THE I-BEAM TO INCLUDE THE EMBEDDED SOLE PLATE FOR FIELD INSTALLATION OF THE BEARING. FIELD WELDING SHALL BE CONTROLLED SO THE TEMPERATURE AT THE ELASTOMER BONDED SURFACE SHALL NOT EXCEED 300° F AS DETERMINED BY THE USE OF PYROMETRIC STICKS OR OTHER TEMPERATURE MONITORING DEVICES.

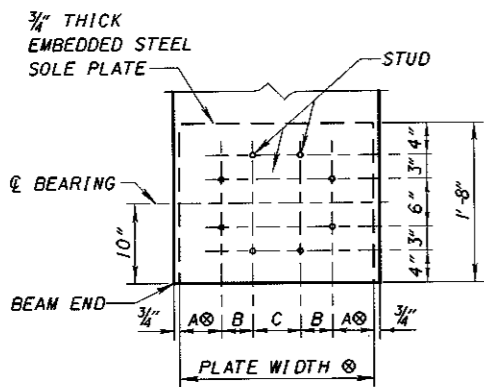

SECTION 2-2
(BEARING AND LOAD PLATE NOT SHOWN)

BOTTOM FLANGE WIDTH	PLATE WIDTH	A	B	C
1'-6"	1'-4 1/2"	3 1/4"	2"	6"
1'-10"	1'-8 1/2"	4 1/4"	4"	4"
2'-2"	2'-0 1/2"	5 1/4"	4"	6"

NOTE - END WELDED STUDS MAY BE MOVED SLIGHTLY IN ORDER TO AVOID REINFORCING STEEL AND PRESTRESSING STRANDS.

⊙ - IN ORDER TO ALLOW FOR FIT-UP, THE PLATE WIDTH MAY BE DECREASED BY $\frac{3}{8}$ ". DIMENSION "A" SHALL BE CORRECTED ACCORDINGLY.

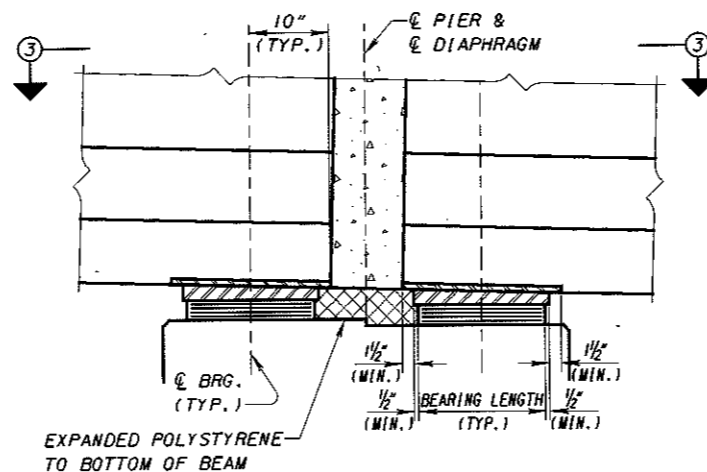

EXPANSION PIER DETAIL
(BEARING WITH LOAD PLATE)

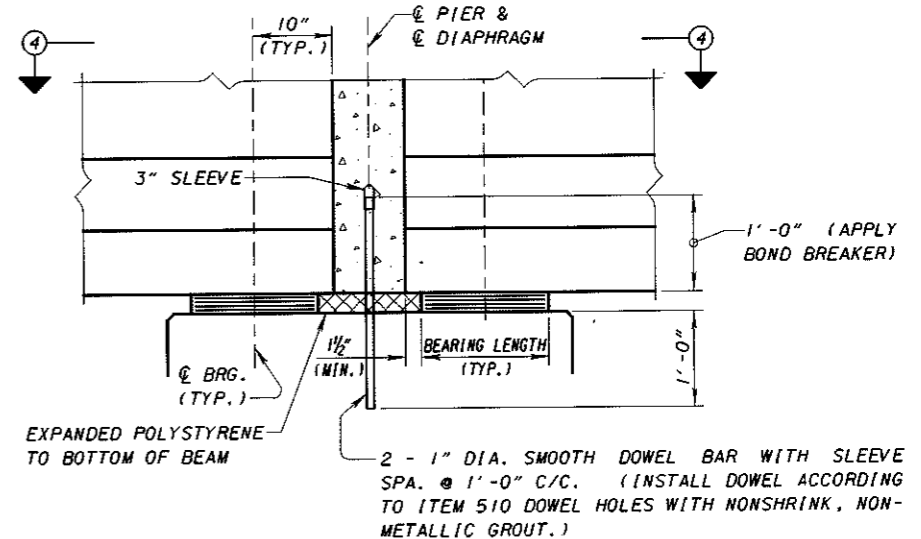

FIXED PIER DETAIL
(BEARING WITH NO LOAD PLATE)

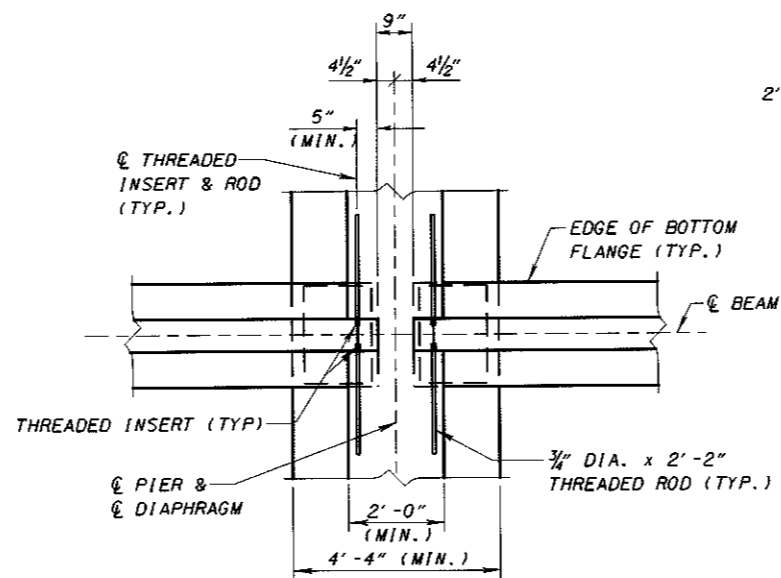

VIEW 3-3
(NO SKEW)

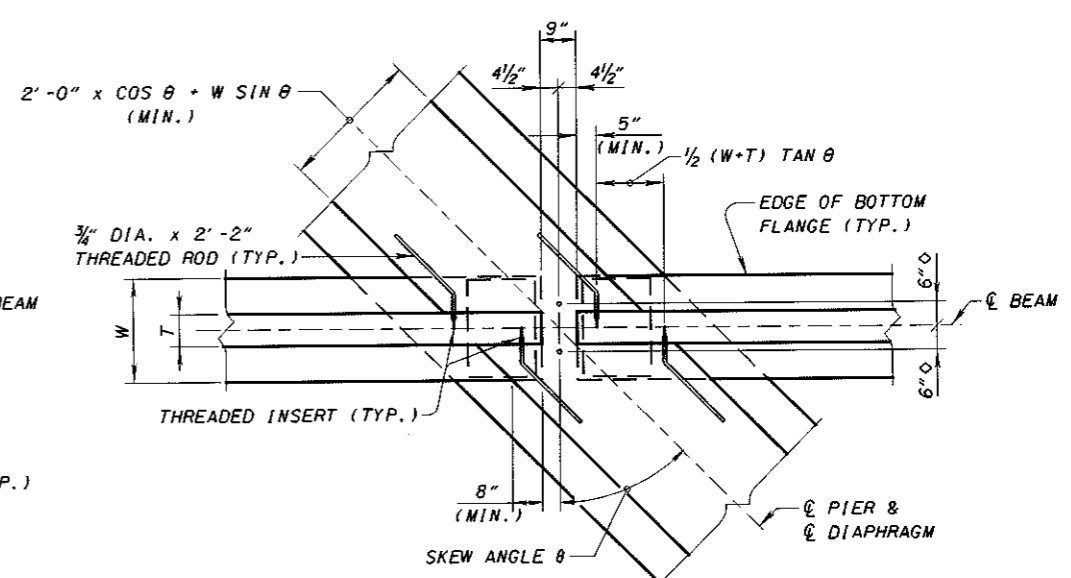

VIEW 4-4
(AT SKEWED PIER)

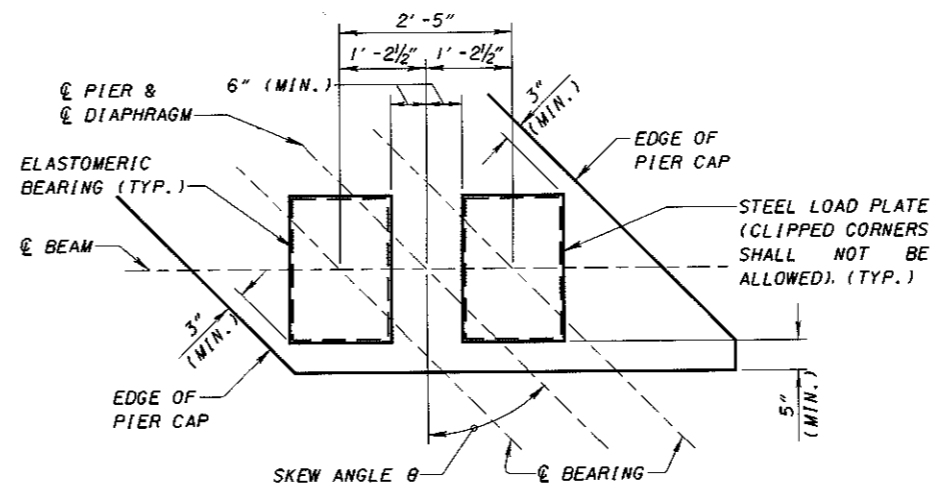

BEARING ORIENTATION AT PIERS
(BEAM NOT SHOWN)

⊙ - MEASURED TO CENTER OF 1" DIA. SMOOTH DOWEL BARS. DOWEL BARS SHALL BE OMITTED AT EXPANSION PIERS.
W - WIDTH OF BOTTOM FLANGE
T - THICKNESS OF WEB

SEE SHEET 5/8 FOR PIER DIAPHRAGM DETAILS.

SEE SHEET 7/8 FOR THREADED INSERT AND ROD DETAILS.