

PLAN VIEW  
APPROACH SLAB PRESSURE RELIEF JOINT

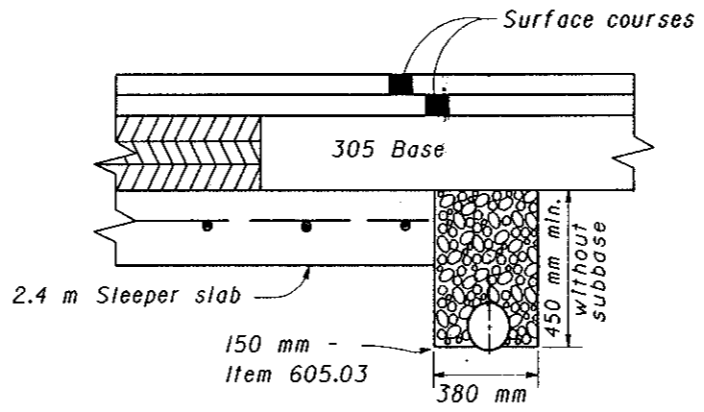

ALTERNATE PAVEMENT DETAIL  
For details not shown, see Section A-A

REINFORCING STEEL LIST				Bending Diagram
Mark	Shape	No.	Length	
R15M01	St.	8	S-.15 m	
R15M02	St.	⊗S	$\frac{2250 \text{ mm}}{\cos \theta}$	
*R15M03	Bt.	S-2	1300 mm	

⊗S = Length of sleeper slab (in meters) ÷ .3  
R15M01 bars may be furnished in segments with a 485 mm bar lap between segments.

APPROACH SLAB PRESSURE RELIEF JOINTS are to be provided when the abutments are integral or semi integral design and the approach pavement is rigid.

ASPHALT CONCRETE, 402 or 404, shall be compacted in equal lifts not Exceeding 75 mm with compaction equipment as approved by the Engineer. Surface of the asphalt concrete shall be flush to the concrete pavement surface. (Tolerance +5 mm -0 mm)

BARRICADES shall be provided during construction until approach slab relief joint has been completed and filled with asphalt.

UNDERDRAIN: Perforated metal pipe underdrain, 707.01 Type III or 707.21 Type III, shall be placed under the pavement side of the approach slab relief joint as detailed. The underdrain shall be outletted to a longitudinal drain, a catch basin or through the embankment or ditch in slope. It shall be installed in accordance with 605 and paid for under Item Special, Approach Slab Pressure Relief Joint.

MEASUREMENT of the pressure relief joint for pay purposes shall be along the centerline of the joint, edge to edge of pavement or back to back of curbs. Payment shall be per linear foot for Item Special, Approach Slab Pressure Relief Joint and shall include all labor, equipment and materials necessary to complete the relief joint.

T = thickness of approach slab as required by project plans  
T' = design pavement thickness as shown on plans

For reinforcing in approach slabs refer to project plans.

★ The surface of the subbase shall be finished smooth and be flush or slightly higher than the surface of the sleeper slab

◆ Care shall be taken in the area beneath the polyethylene film to be sure the surface of the subbase or subgrade is finished smooth and is flush with or slightly higher than the surface of the sleeper slab.

\* R15M03 required only if approach slab pressure relief joint is not to be used for pavement expansion.

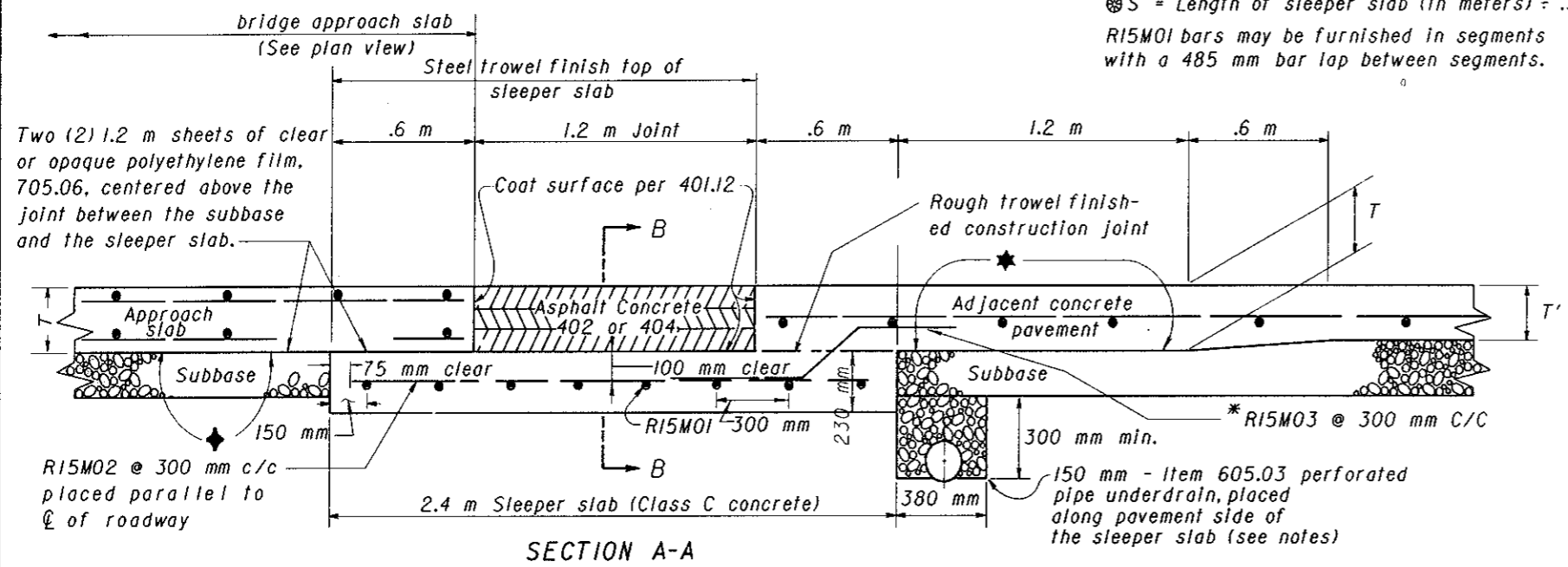

SECTION A-A

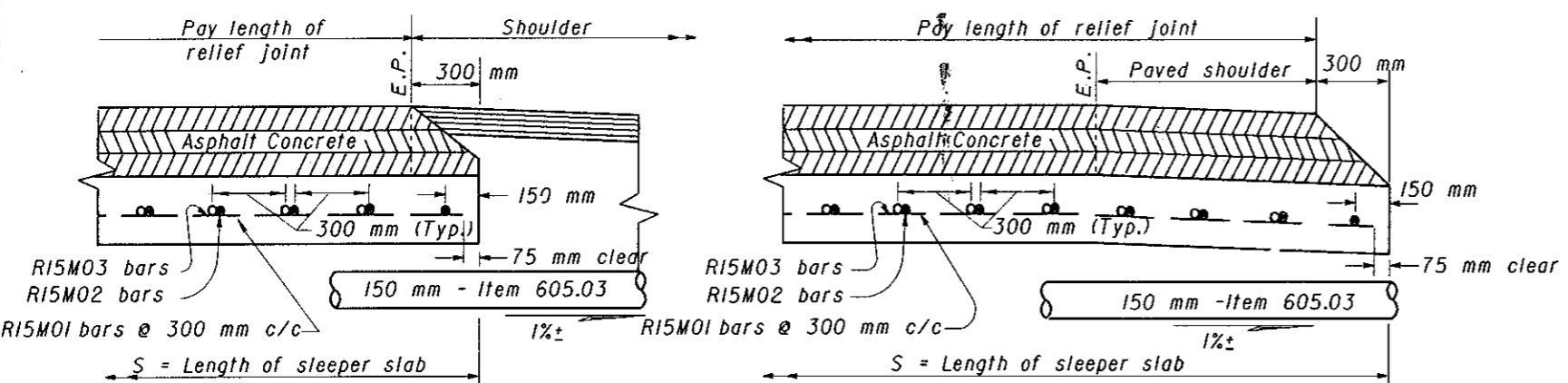

SECTION B-B WITH ASPHALT SHOULDERS

SECTION B-B WITH CONCRETE SHOULDERS