

TABLE A

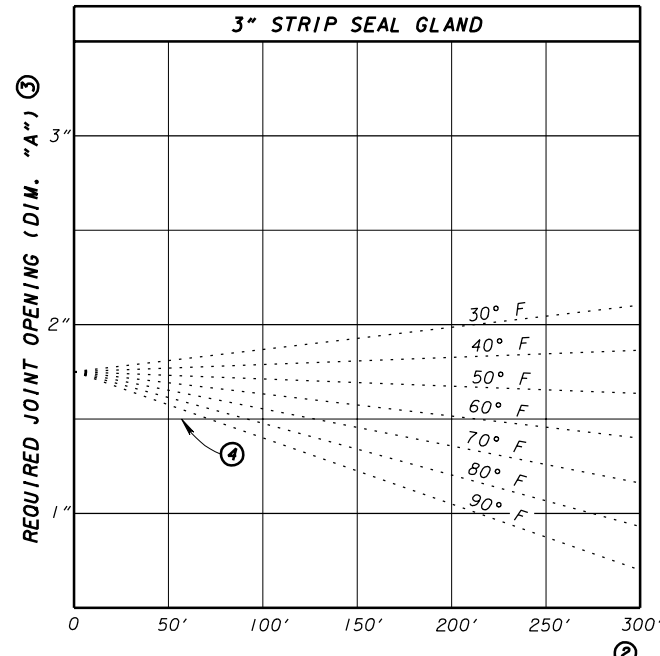

TABLE B

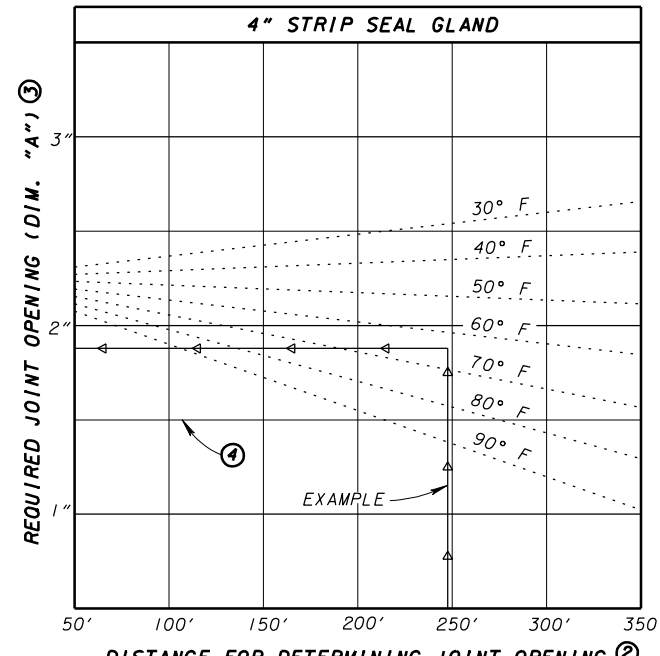

TABLE C

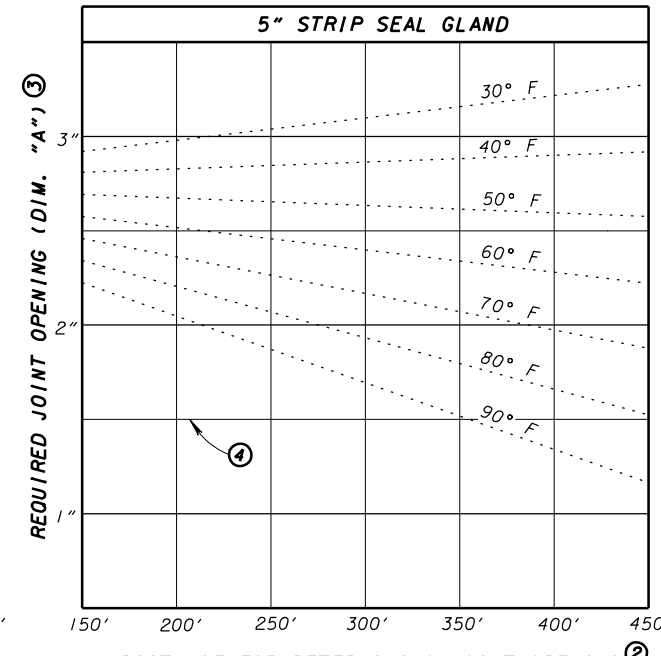

TABLE D

LEGEND

- ① - THIS IS THE ACTUAL DISTANCE FROM THE CENTERLINE OF JOINT TO THE THERMAL NEUTRAL POINT OF THE SUPERSTRUCTURE MEASURED ALONG THE CENTERLINE OF ROADWAY. THIS DIMENSION SHALL BE A MAXIMUM OF 299' FOR 60° SKEWS, 342' FOR 45° SKEWS, 385' FOR 30° SKEWS AND 427' FOR 0° THRU 15° SKEWS. THE THERMAL NEUTRAL POINT OF THE SUPERSTRUCTURE IS THAT POINT WHICH HAS ZERO HORIZONTAL MOVEMENT DURING TEMPERATURE CHANGES.
- ② - THIS DISTANCE FOR EXPANSION JOINTS HAVING SKEW ANGLES OF 15° OR LESS IS THE ACTUAL DISTANCE TO THE THERMAL NEUTRAL POINT OF THE SUPERSTRUCTURE ALONG THE CENTERLINE OF ROADWAY. THIS DISTANCE FOR EXPANSION JOINTS HAVING SKEW ANGLES OVER 15° BUT NOT GREATER THAN 60° IS ARRIVED AT BY MULTIPLYING THE ABOVE DEFINED DISTANCE ALONG THE CENTERLINE OF ROADWAY BY THE COSINE OF THE EXPANSION JOINT SKEW ANGLE.
- ③ - THIS IS THE JOINT OPENING (DIMENSION "A") REQUIRED AT THE TIME OF ABUTMENT BACKWALL CONCRETE PLACEMENT, BASED ON THE DAY'S ANTICIPATED PEAK AMBIENT TEMPERATURE.
- ④ - MINIMUM JOINT OPENING (DIMENSION "A") AT TIME OF SEAL GLAND INSTALLATION SHALL NOT BE LESS THAN 1 1/2". IF THE JOINT OPENING IS LESS, INSTALLATION SHALL BE POSTPONED UNTIL THE TEMPERATURE DROPS A SUFFICIENT AMOUNT TO ALLOW THE MINIMUM 1 1/2" OPENING.

EXAMPLE

GIVEN - THE DISTANCE FROM THE CENTERLINE OF THE JOINT TO THE THERMAL NEUTRAL POINT OF THE SUPERSTRUCTURE ALONG THE CENTERLINE OF THE ROADWAY IS 287.5'. THE SKEW ANGLE OF THE EXPANSION JOINT IS 30° AND THE ANTICIPATED AMBIENT TEMPERATURE AT TIME OF JOINT INSTALLATION IS 65° F.

FIND - REQUIRED STRIP SEAL GLAND SIZE AND THE JOINT OPENING (DIMENSION "A") AT THE TIME OF JOINT ARMOR INSTALLATION.

SOLUTION -

- (A) ENTER TABLE "A" AT ① WITH 287.5' AND FIND THAT THE REQUIRED STRIP SEAL GLAND SIZE IS 4 INCHES.
- (B) ENTER TABLE "C" AT ② WITH 287.5' X COSINE OF 30° = 248.98' AND FIND REQUIRED JOINT OPENING AT 65° F IS 1.86".

NOTE: STEP (B) REQUIRED ONLY AT TIME OF CONSTRUCTION.

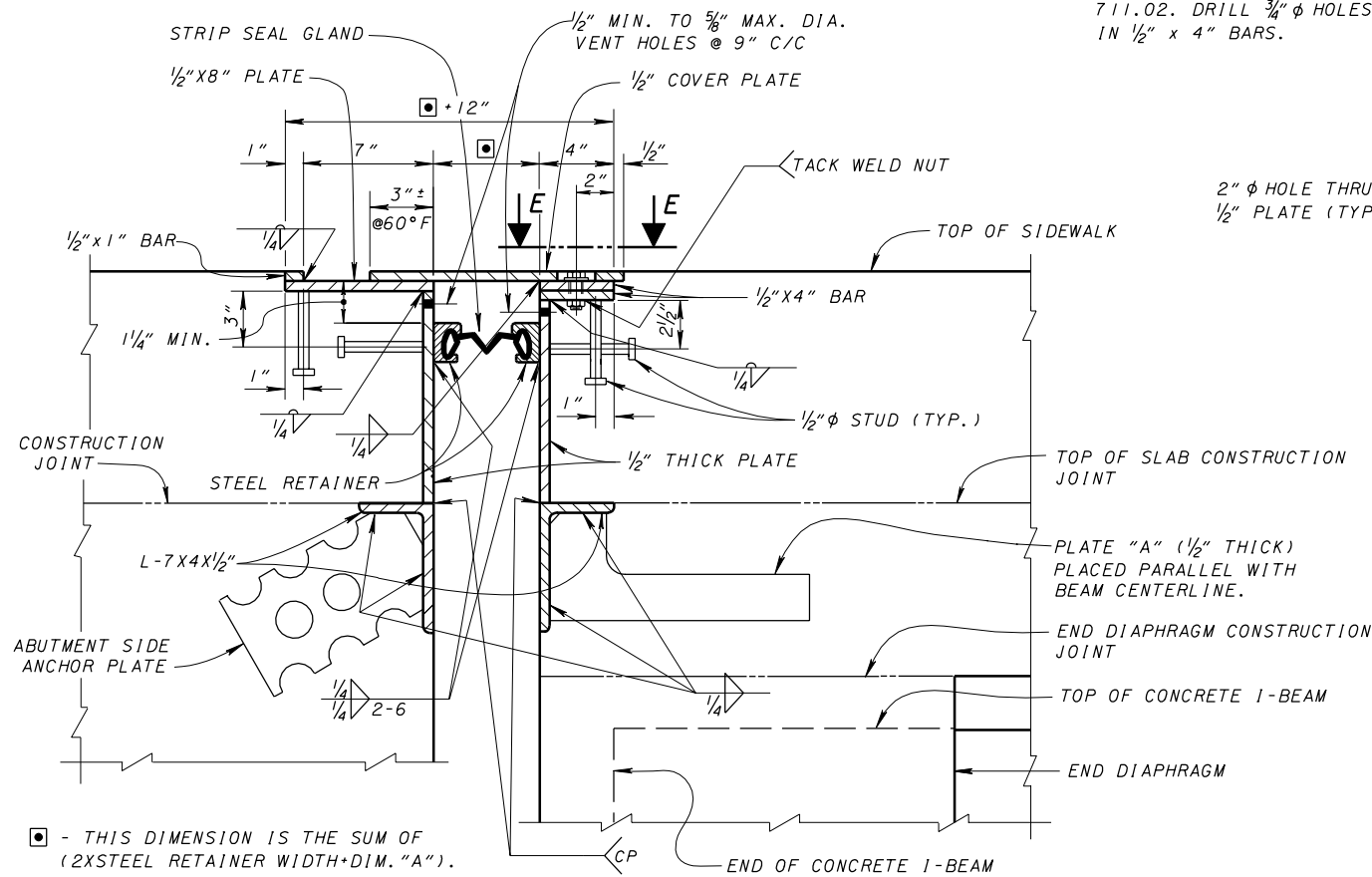

SECTION Y-Y

4 5/8" φ x 2" BOLTS, ASTM A307 WITH HEX NUTS AND WASHER GALVANIZED PER 711.02. DRILL 3/4" φ HOLES IN 1/2" x 4" BARS.

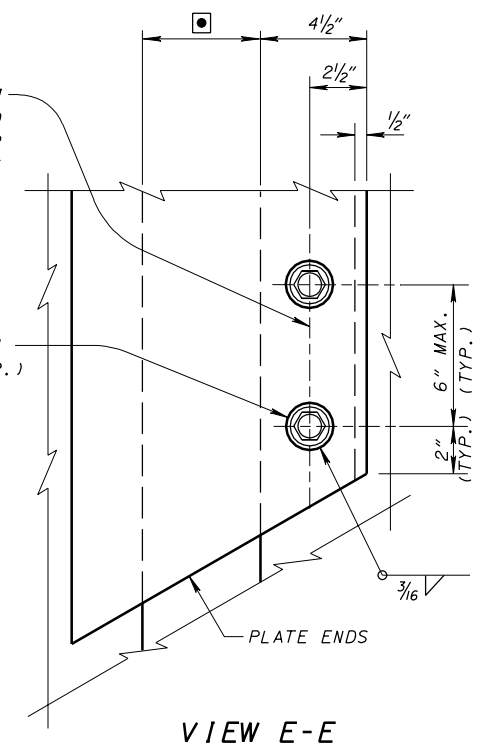

VIEW E-E