

**PARTIAL PLAN AT ABUTMENT**

BRIDGE WITH SINGLE SLOPE CONCRETE BRIDGE RAILING  
(SBR-1-13 RAILING IS SHOWN, BR-1-13 RAILING IS SIMILAR)

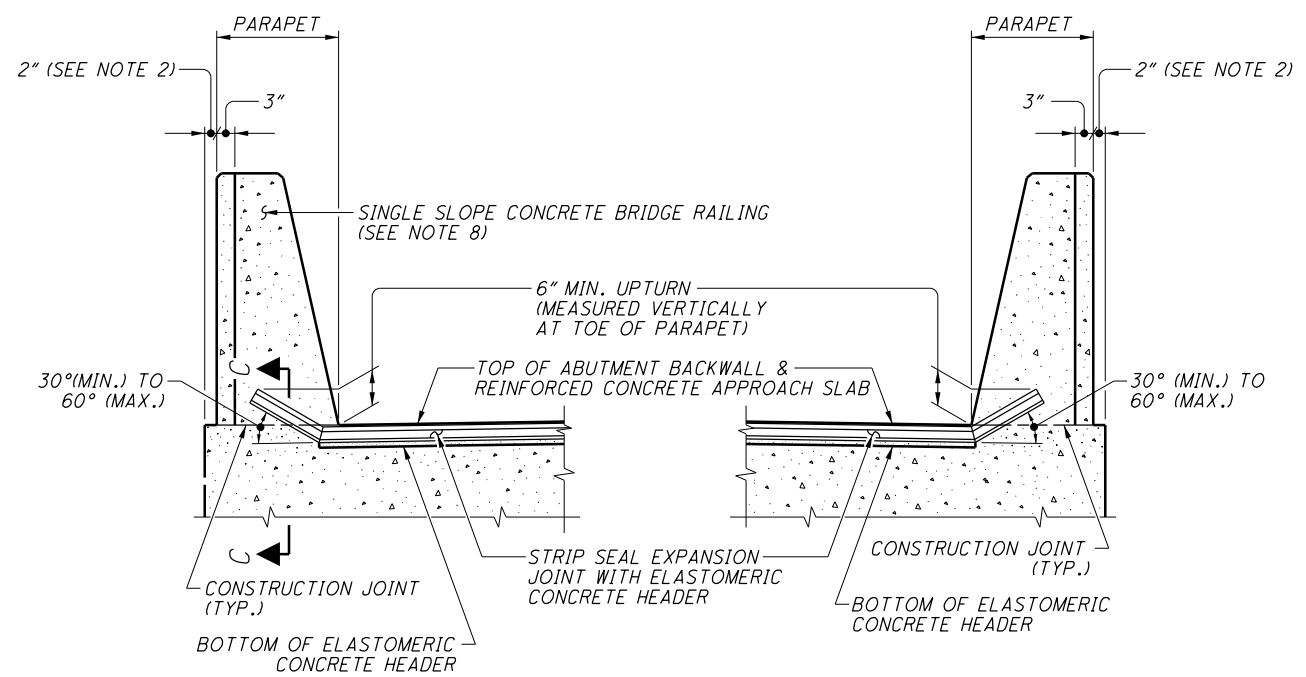

**SECTION B-B**

REINFORCING STEEL NOT SHOWN  
SBR-1-13 RAILING IS SHOWN, BR-1-13 RAILING IS SIMILAR

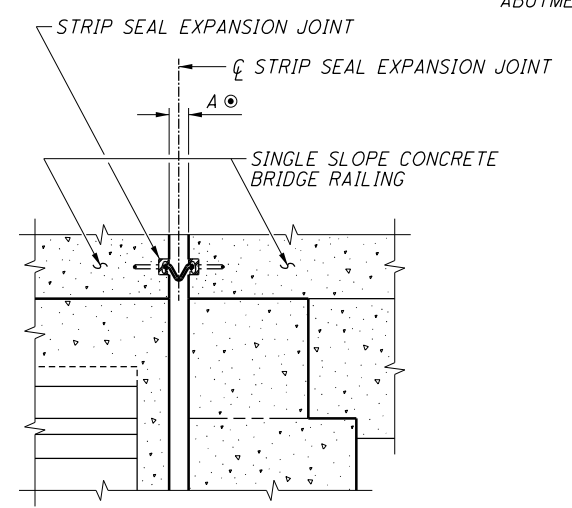

**SECTION C-C**

REINFORCING STEEL NOT SHOWN

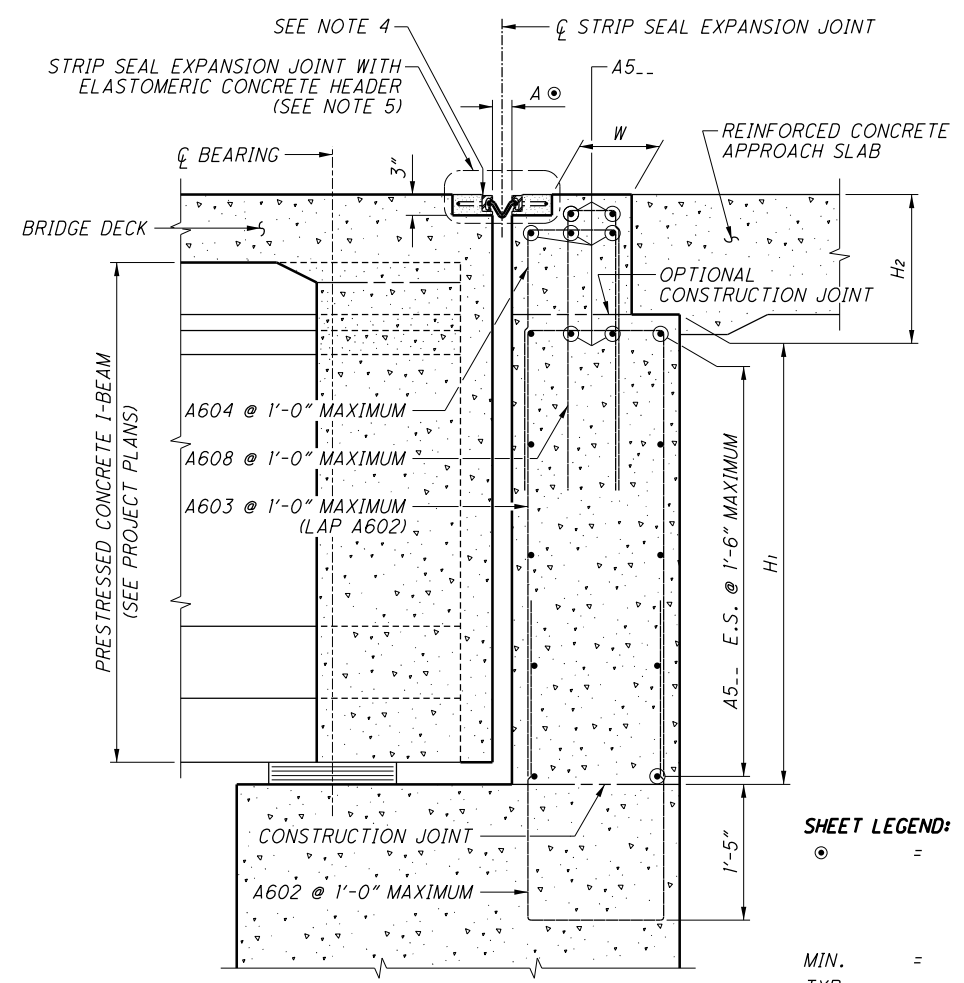

**SECTION A-A**

ABUTMENT BREAST WALL REINFORCING STEEL NOT SHOWN  
SEE NOTE 3

**SHEET LEGEND:**

- ⊕ = DETERMINE DIMENSION "A" FROM TABLE PROVIDED IN PROJECT PLANS (SEE NOTE 7)
- MIN. = MINIMUM
- TYP. = TYPICAL
- W, H<sub>1</sub>, H<sub>2</sub> = SEE NOTE 6

EPOXY COATED REINFORCING STEEL		
MARK	LENGTH	TYPE
A5--	⊕	STR
A601	NOT USED	
A602	11'-7"	BENT
A603	(2H <sub>1</sub> ) + 7"	BENT
A604	(2H <sub>2</sub> ) + 3'-5"	BENT
A605	NOT USED	
THROUGH A607		
A608	W + (2H <sub>2</sub> ) + 4'-6"	BENT

  

BENDING DIAGRAMS	
A	A602 THROUGH A604, A608 (SEE NOTE 6)
B	A602 THROUGH A604, A608 (SEE NOTE 6)
A602	1'-5"
A603	1'-5"
A604	11"
A608	W - 4"

⊕ SEE PROJECT PLANS.

**NOTES:**

1. PROVIDE 6'-0" CLOSURE POUR AT THE CONCRETE BRIDGE RAILING ADJACENT TO THE STRIP SEAL EXPANSION JOINT TO ACCOMMODATE THE INSTALLATION OF STRIP SEAL GLAND UNDERNEATH THE CONCRETE BRIDGE RAILING. (SEE GENERAL NOTES)
2. FOR REINFORCED CONCRETE APPROACH SLAB, SEE STD. BRIDGE DWG. AS-1-15 AND STD. BRIDGE DWG. AS-2-15.
3. FOR TYPICAL ABUTMENT DETAILS, SEE STD. BRIDGE DWG. A-1-69.
4. SEE DETAIL C ON SHEET [3/5] FOR ELASTOMERIC CONCRETE HEADER AND JOINT SEAL STEEL RETAINER DIMENSIONS.
5. FOR STRIP SEAL EXPANSION JOINT NOTE, SEE SHEET [3/5].
6. SEE PROJECT PLANS FOR DIMENSIONS OF W, H<sub>1</sub>, AND H<sub>2</sub>.
7. FOR AN EXAMPLE ON HOW TO DETERMINE STRIP SEAL GLAND OPENING DIMENSION, SEE SHEET [4/5].
8. FOR NEW JERSEY SHAPE AND SINGLE SLOPE CONCRETE BRIDGE RAILINGS, SEE STD. BRIDGE DWG. BR-1-13 AND STD BRIDGE DWG. SBR-1-13, RESPECTIVELY.
9. PAYMENT FOR EPOXY COATED REINFORCING STEEL SHALL BE INCLUDED WITH ITEM 509 - EPOXY COATED REINFORCING STEEL.
10. FOR GENERAL NOTES, SEE SHEET [5/5].

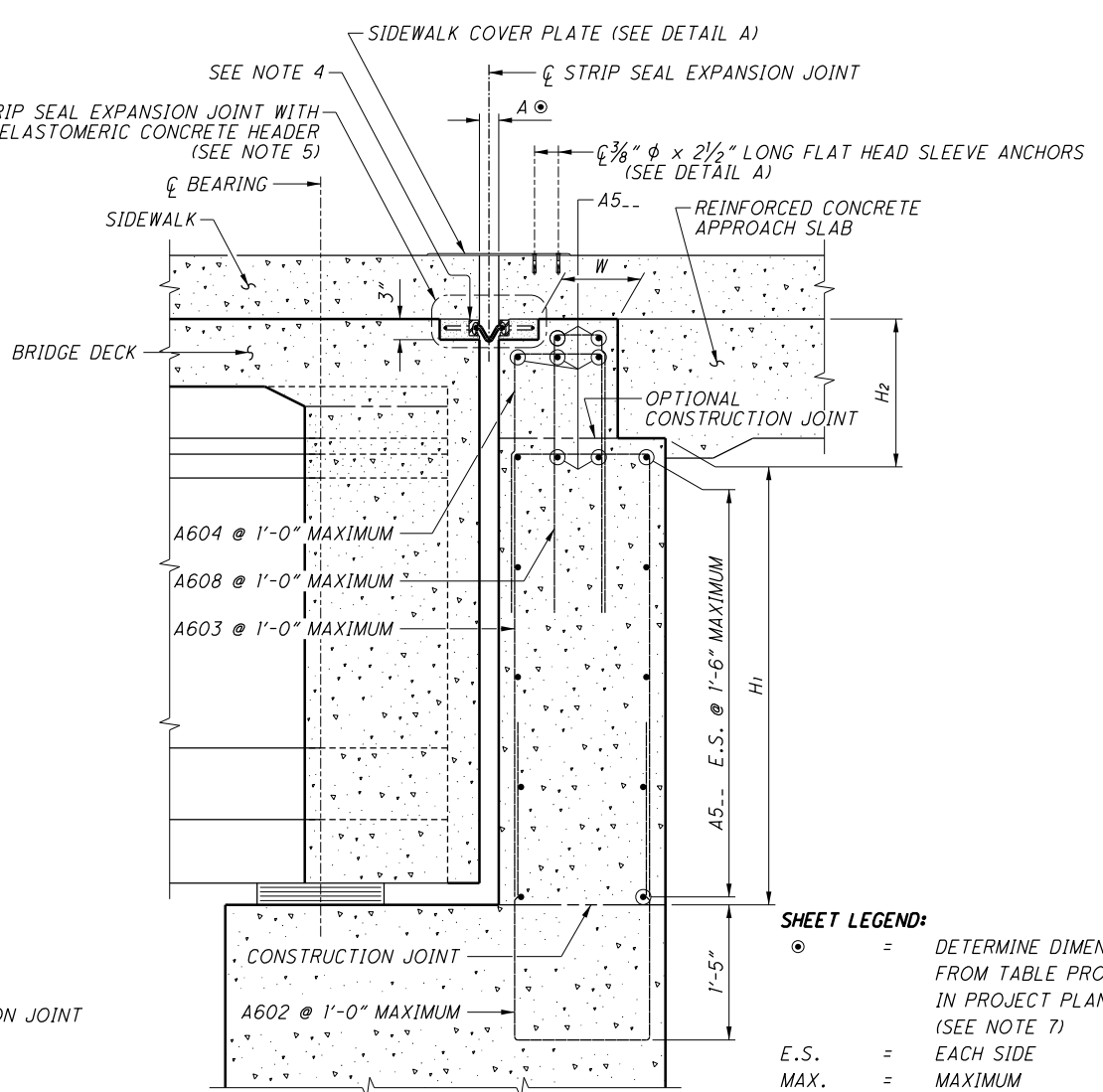
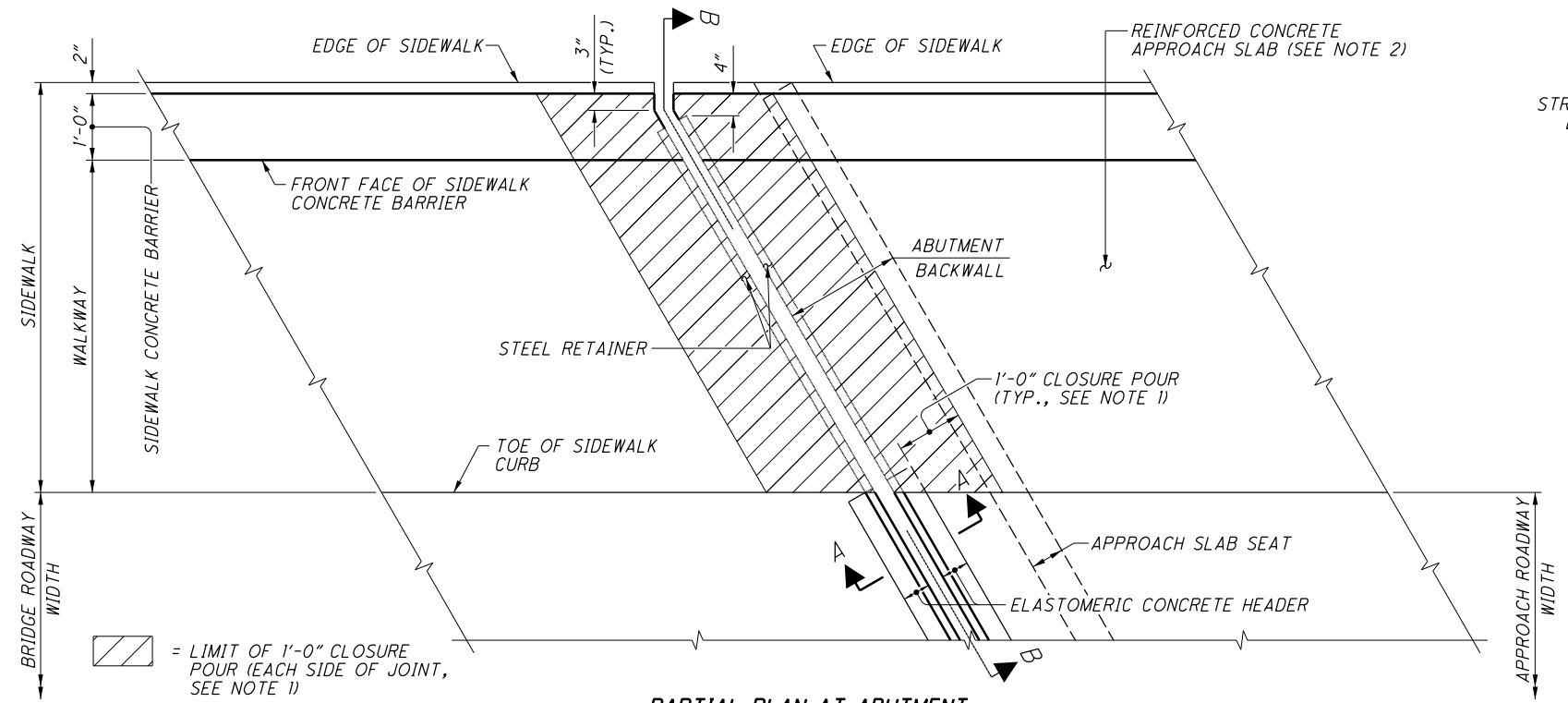

**SHEET LEGEND:**

- ⊙ = DETERMINE DIMENSION "A" FROM TABLE PROVIDED IN PROJECT PLANS (SEE NOTE 7)
- E.S. = EACH SIDE
- MAX. = MAXIMUM
- MIN. = MINIMUM
- SPA. = SPACES
- TYP. = TYPICAL
- W, H<sub>1</sub>, H<sub>2</sub> = SEE NOTE 6

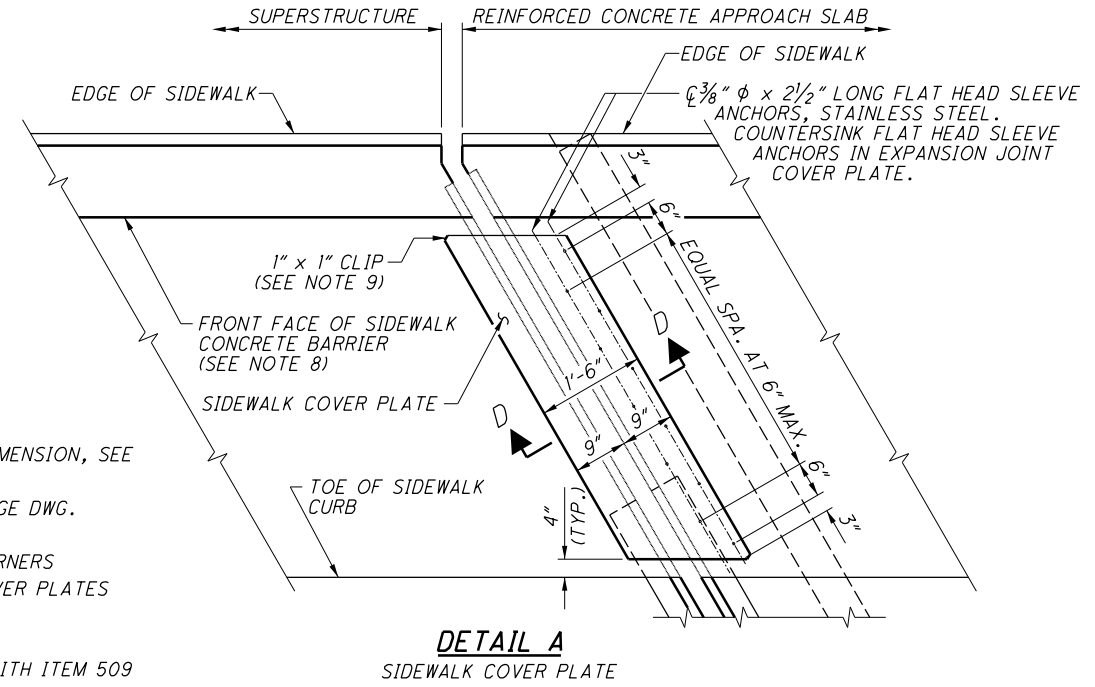
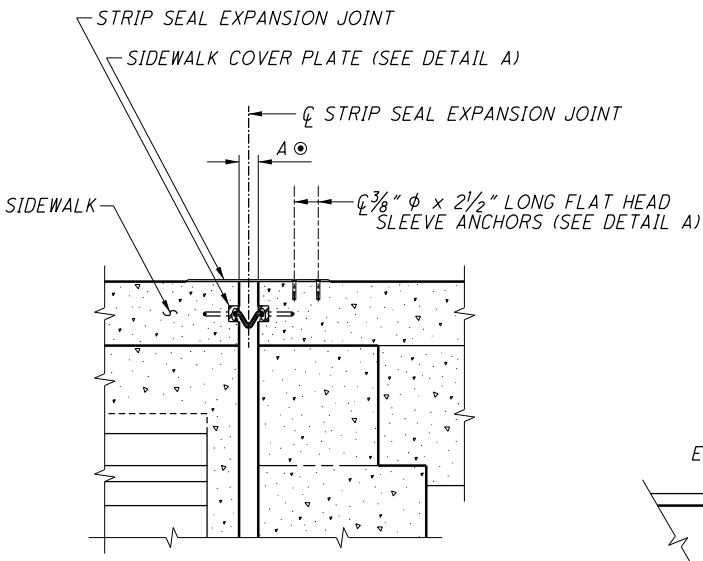
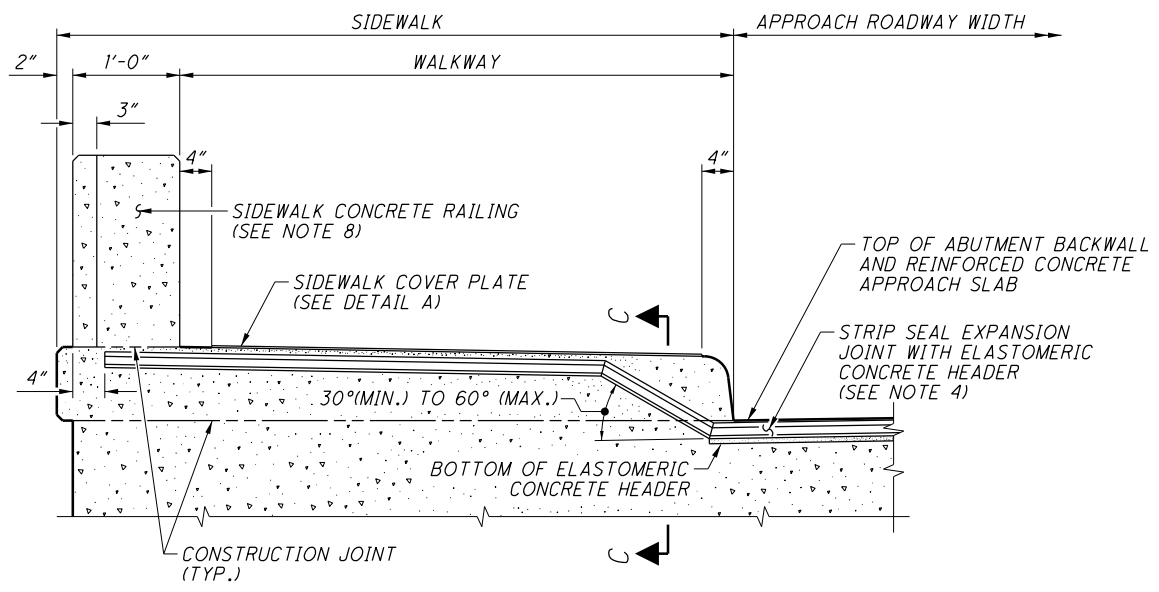

- NOTES:**
1. PROVIDE 1'-0" CLOSURE POUR, MEASURED FROM THE EDGE OF THE ELASTOMERIC CONCRETE HEADER AND PERPENDICULAR TO THE SKEW AS SHOWN IN THE PARTIAL PLAN VIEW AT ABUTMENT, TO ACCOMMODATE THE INSTALLATION OF STRIP SEAL EXPANSION JOINT AT THE SIDEWALK. (SEE GENERAL NOTES)
  2. FOR REINFORCED CONCRETE APPROACH SLAB, SEE STD. BRIDGE DWG. AS-1-15 AND STD. BRIDGE DWG. AS-2-15.
  3. FOR TYPICAL ABUTMENT DETAILS, SEE STD. BRIDGE DWG. A-1-69.
  4. SEE DETAIL C ON SHEET [3/5] FOR ELASTOMERIC CONCRETE HEADER AND JOINT SEAL STEEL RETAINER DIMENSIONS.
  5. FOR STRIP SEAL EXPANSION JOINT NOTE AND SECTION D-D, SEE SHEET [3/5].
  6. SEE PROJECT PLANS FOR DIMENSIONS OF W, H<sub>1</sub>, AND H<sub>2</sub>.

7. FOR AN EXAMPLE ON HOW TO DETERMINE STRIP SEAL GLAND OPENING DIMENSION, SEE SHEET [4/5].
8. FOR BRIDGE SIDEWALK RAILING WITH CONCRETE BARRIER, SEE STD. BRIDGE DWG. BR-2-15.
9. SIDEWALK COVER PLATES SHALL BE CLIPPED 1" x 1" AT ACUTE ANGLE CORNERS ONLY. FOR 0° SKEW BRIDGES, ALL FOUR (4) CORNERS OF SIDEWALK COVER PLATES SHALL BE CLIPPED 1" x 1".
10. FOR EPOXY COATED REINFORCING STEEL LIST, SEE SHEET [7/5].
11. PAYMENT FOR EPOXY COATED REINFORCING STEEL SHALL BE INCLUDED WITH ITEM 509 - EPOXY COATED REINFORCING STEEL.
12. FOR GENERAL NOTES, SEE SHEET [5/5].

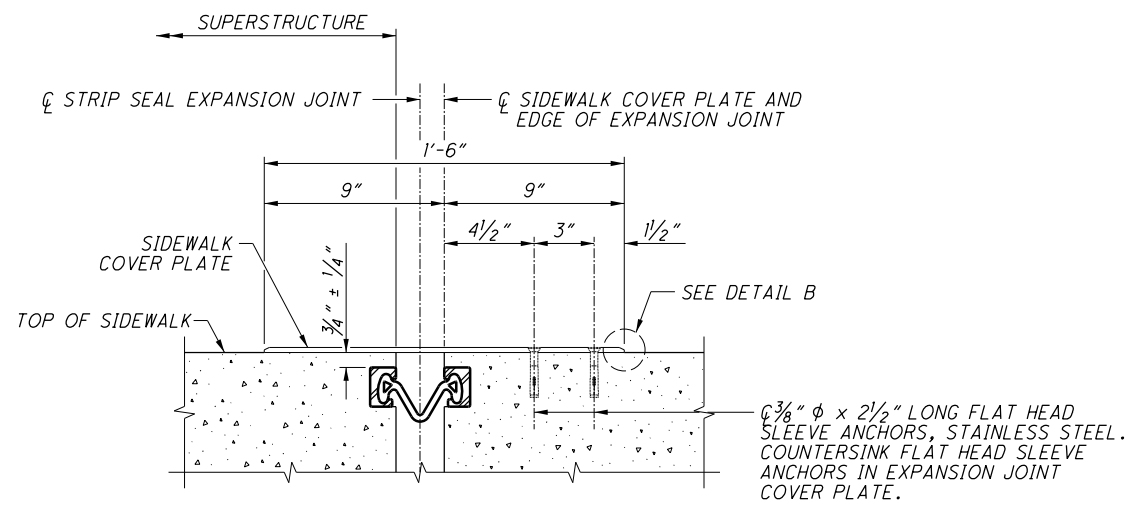

**SECTION D-D**

SIDEWALK REINFORCING STEEL NOT SHOWN

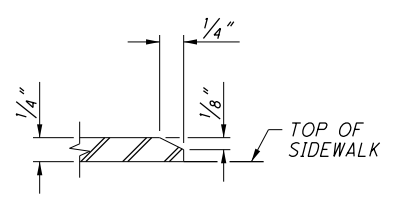

**DETAIL B**

SIDEWALK COVER PLATE - BEVEL DETAIL

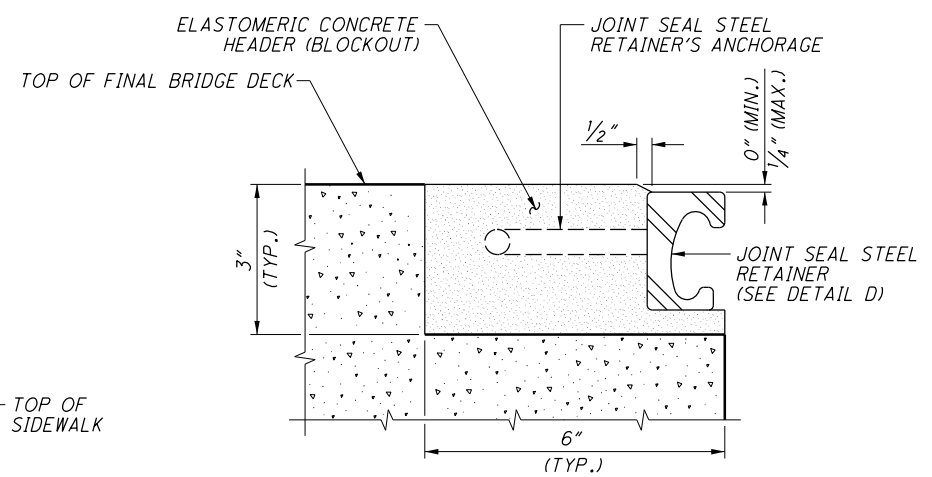

**DETAIL C**

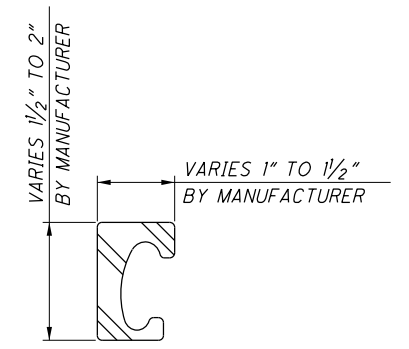

**DETAIL D**

STEEL RETAINER DETAIL

**ITEM 516 - SIDEWALK COVER PLATE:**

FURNISH 3/8" THICK, SLIP RESISTANT GALVANIZED SIDEWALK COVER PLATES FABRICATED FROM STRUCTURAL STEEL MEETING ASTM A709, GRADE 36 OR 50.

FABRICATE STEEL COVER PLATES IN ACCORDANCE WITH DETAILS SHOWN IN THIS STANDARD BRIDGE DRAWING.

AFTER SHOP FABRICATION, HOT-DIP GALVANIZE SLIP RESISTANT COVER PLATES IN ACCORDANCE WITH CMS 711.02 AND COVER PLATE MANUFACTURER'S RECOMMENDATIONS, EXCEPT AS NOTED HEREIN.

SIDEWALK COVER PLATES SHALL BE ANTI-SLIP STEEL SURFACE CONSISTING OF A RANDOM HATCH MATRIX OR OTHER SUITABLE PATTERN. CHECKER PLATE OR DIAMOND PLATE IS NOT ALLOWED NOR ARE SURFACE APPLIED SLIP RESISTANT TAPES, FILMS, NON-METALLIC COATINGS, AND OTHER SIMILAR MATERIALS.

BEVEL ALL PLATE EDGES AS SHOWN IN DETAIL B ON THIS SHEET. TRANSVERSE EDGES MUST BE IN CONTACT WITH SIDEWALK SURFACES AFTER INSTALLATION.

PROVIDE 3/8" DIA. x 2 1/2" LONG, FLAT HEAD SLEEVE ANCHORS, STAINLESS STEEL MEETING THE REQUIREMENTS OF ASTM F593, GROUP 1, ALLOY 304. COUNTERSINK FLAT HEAD SLEEVE ANCHORS IN SLIP-RESISTANT SIDEWALK COVER PLATE. SHOP DRILL HOLES IN SIDEWALK COVER PLATE AS PER SLEEVE ANCHOR MANUFACTURER'S RECOMMENDATIONS. INSTALL SLEEVE ANCHORS FLUSH WITH, OR SLIGHTLY RECESSED BELOW TOP SURFACE OF EXPANSION JOINT COVER PLATE.

SEAL THE SURFACE OF THE SIDEWALK WITHIN THE LIMITS OF THE COVER PLATE WITH AN EPOXY-URETHANE SEALER AS SPECIFIED IN CMS 512.03. ADDITIONALLY, SEAL THE UNDERSIDE OF THE SIDEWALK COVER PLATE WITH THE SAME EPOXY-URETHANE SEALER PRIOR TO ITS INSTALLATION. SURFACE PREPARATION OF THE SIDEWALK COVER PLATE IS WAIVED.

AFTER INSERTION OF THE ANCHOR AND PRIOR TO TIGHTENING, PLACE CAULKING UNDER THE HEAD OF THE SCREW IN SUFFICIENT QUANTITY SO AS TO COMPLETELY SEAL THE ANCHOR FROM MOISTURE INTRUSION. REMOVE EXCESS MATERIAL WITHOUT DAMAGE TO THE SURFACE COATING OF THE SIDEWALK COVER PLATE PRIOR TO ITS DRYING. THE CAULK IS TO BE A POLYURETHANE OR POLYMERIC MATERIAL CONFORMING TO ASTM C920, TYPE S.

**SHEET NOTES:**

- FOR LOCATION OF SECTION D-D, SEE SHEET [2/5].
- FOR LOCATIONS OF DETAIL C, SEE SHEETS [1/5] AND [2/5].
- FOR AN EXAMPLE ON HOW TO DETERMINE JOINT SEAL OPENING DIMENSION, SEE SHEET [4/5].
- FOR GENERAL NOTES, SEE SHEET [5/5].

**ITEM 516 - SIDEWALK COVER PLATE (CONT.):**

SIDEWALK COVER PLATES CAN ACCOMMODATE UP TO 6" MAXIMUM EXPANSION JOINT MOVEMENT, MEASURED IN PERPENDICULAR DIRECTION FROM THE CENTERLINE OF BEARINGS.

THE DEPARTMENT WILL MEASURE SIDEWALK COVER PLATE BY THE NUMBER OF POUNDS

THE DEPARTMENT WILL PAY FOR ACCEPTED QUANTITIES AT THE CONTRACT PRICE BY THE NUMBER OF POUNDS FOR ITEM 516 - SIDEWALK COVER PLATE.

**ITEM 516 - STRIP SEAL EXPANSION JOINT ANCHORED WITH ELASTOMERIC CONCRETE:**

INSTALL THE STRIP SEAL EXPANSION JOINT SYSTEM IN ACCORDANCE WITH THE MANUFACTURER'S SPECIFICATIONS AND INSTALLATION PROCEDURES. AN EXPERIENCED TECHNICAL REPRESENTATIVE OF THE MANUFACTURER SHALL BE PRESENT TO SUPERVISE ALL PHASES OF MATERIAL INSTALLATION TO ENSURE THAT THE JOINT SEAL IS BEING INSTALLED PROPERLY.

SELECT BOTH THE STRIP SEAL EXPANSION JOINT SYSTEM AND ELASTOMERIC CONCRETE FROM ONE OF THE MANUFACTURERS LISTED BELOW:

WATSON BOWMAN ACME CORP.  
95 PINEVIEW DRIVE  
AMHERST, NY 14228-2121  
PHONE: (716) 691-7566  
FAX: (716) 691-9239

- WABOCRETE STRIPSEAL EXPANSION JOINT SYSTEM, TYPE A OR TYPE E STEEL EDGE MEMBER:

MODEL NUMBER	MAX. MOVEMENT RATING	MIN. INSTALLATION WIDTH (DIMENSION "A")
CRETE SE-300	3"	1 1/2"
CRETE SE-400	4"	1 1/2"
CRETE SE-500	5"	2"

D.S. BROWN COMPANY  
300 EAST CHERRY STREET  
NORTH BALTIMORE, OH 45872-1227  
PHONE: (419) 257-3561  
FAX: (419) 257-2200

- DELCRETE STRIP SEAL JOINT SYSTEM WITH STEELFLEX SSE2M OR SSA2 RAIL PROFILE:

MODEL NUMBER	MAX. MOVEMENT RATING	MIN. INSTALLATION WIDTH (DIMENSION "A")
A2R-400	4"	2"
A2R-XTRA	5"	2"

**ITEM 516 - STRIP SEAL EXPANSION JOINT ANCHORED WITH ELASTOMERIC CONCRETE (CONT.):**

THE NEOPRENE STRIP SEAL GLAND, ELASTOMERIC CONCRETE HEADER, JOINT SEAL STEEL RETAINER (STEEL RAIL PROFILE) LUBRICANT-ADHESIVE, AND STEEL RETAINER'S ANCHORAGE METHOD ARE AN INTEGRAL JOINT SYSTEM THAT SHALL BE DESIGNED AND SUPPLIED BY THE SAME MANUFACTURER.

FOR STRUCTURES WITHOUT REINFORCED CONCRETE SIDEWALK, SET THE TOP OF THE JOINT SEAL STEEL RETAINER BETWEEN 0" TO 1/4" (MAX.) BELOW FINAL SURFACE ELEVATION AS SHOWN IN DETAIL C ON THIS SHEET. THE JOINT SEAL SHALL BEND UPWARD INSIDE THE CONCRETE BRIDGE RAILING FOR A MINIMUM OF 6" UPTURN MEASURED VERTICALLY FROM THE TOE OF THE CONCRETE BRIDGE RAILING AND AT AN ANGLE BETWEEN 30° AND 60° MEASURED FROM THE HORIZONTAL LINE AT THE BEND POINT AS SHOWN IN SECTION B-B, SHEET [1/5].

FOR STRUCTURES WITH REINFORCED CONCRETE SIDEWALK, THE JOINT SEAL SHALL BEND UPWARD INSIDE THE SIDEWALK TO AN ELEVATION 3/4" ± 1/4" BELOW THE TOP SURFACE OF THE SIDEWALK AND AT AN ANGLE BETWEEN 30° AND 60° MEASURED FROM THE HORIZONTAL LINE AT THE BEND POINT AS SHOWN IN SECTION B-B, SHEET [2/5]. PROVIDE TEMPORARY SUPPORT DURING THE INSTALLATION OF JOINT SEAL IN THE SIDEWALK PRIOR TO CLOSURE POUR.

SUPPLY THE MANUFACTURER'S JOINT SEAL INSTALLATION PROCEDURES, TECHNICAL DATA INCLUDING TEST RESULTS, AND SPECIFICATIONS TO THE ENGINEER AT LEAST SEVEN (7) DAYS BEFORE CONSTRUCTION OF THE JOINT BEGINS. THE DEPARTMENT'S ACCEPTANCE IS NOT REQUIRED.

THE DEPARTMENT WILL MEASURE THE ARMORLESS PREFORMED JOINT SEAL BY THE NUMBER OF FEET ALONG THE ENTIRE LENGTH OF INSTALLED JOINT SEAL.

THE DEPARTMENT WILL PAY FOR THE ACCEPTED QUANTITIES AT THE CONTRACT PRICE BY THE NUMBER OF FEET FOR ITEM 516 - STRIP SEAL EXPANSION JOINT ANCHORED WITH ELASTOMERIC CONCRETE.

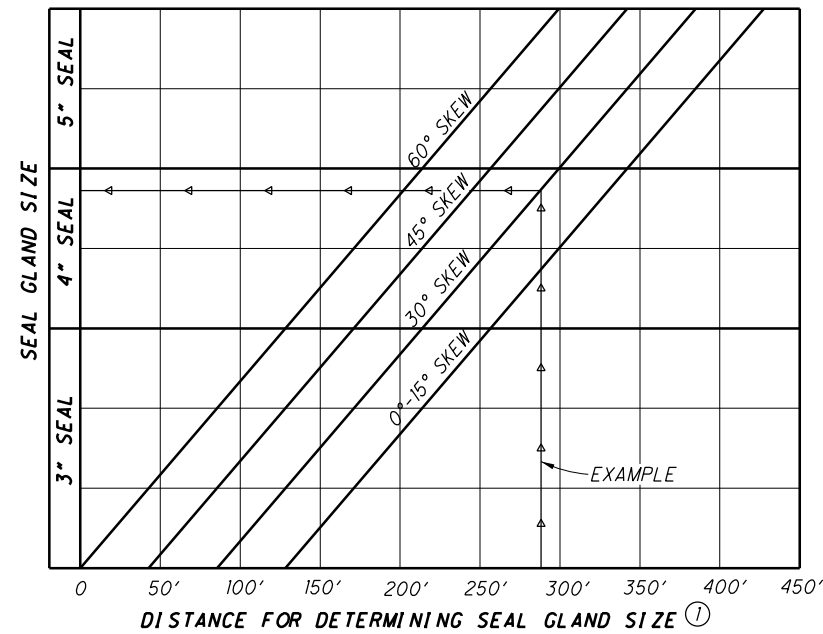

TABLE A

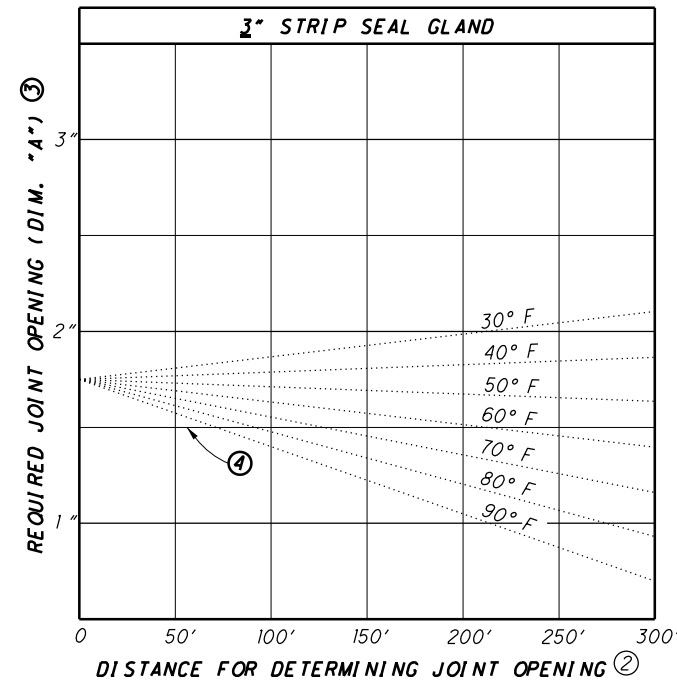

TABLE B

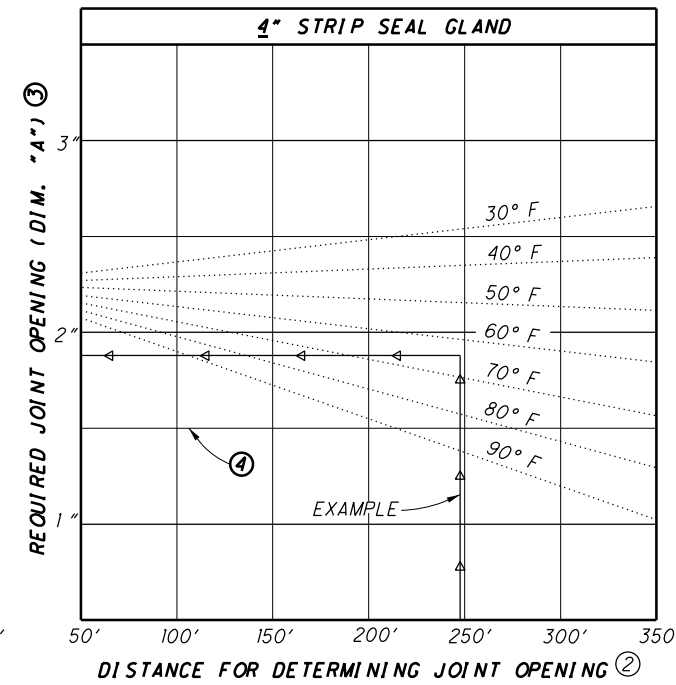

TABLE C

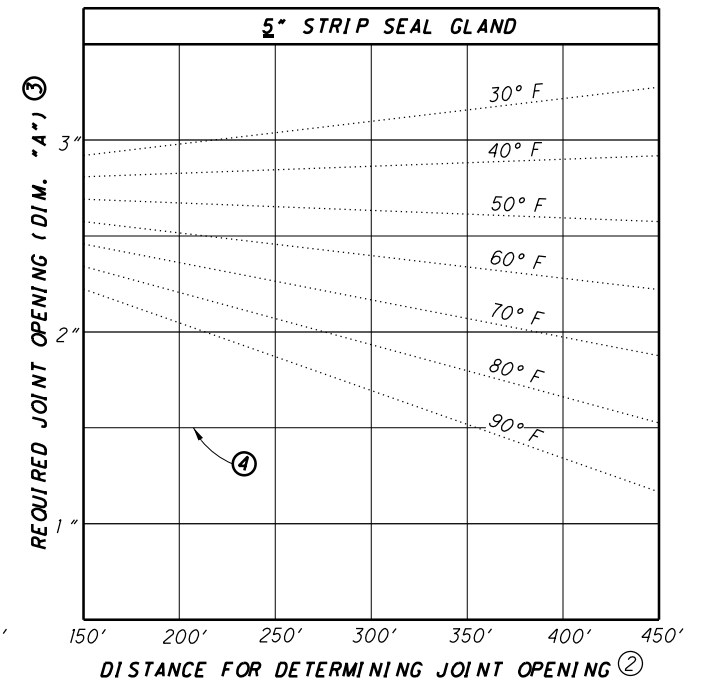

TABLE D

**LEGEND**

- ① - THIS IS THE ACTUAL DISTANCE FROM THE CENTERLINE OF JOINT TO THE THERMAL NEUTRAL POINT OF THE SUPERSTRUCTURE MEASURED ALONG THE CENTERLINE OF ROADWAY. THIS DIMENSION SHALL BE A MAXIMUM OF 299 FEET FOR 60° SKEWS, 342 FEET FOR 45° SKEWS, 385 FEET FOR 30° SKEWS, AND 427 FEET FOR 0° THROUGH 15° SKEWS. THE THERMAL NEUTRAL POINT OF THE SUPERSTRUCTURE IS THAT POINT WHICH HAS ZERO HORIZONTAL MOVEMENT DURING TEMPERATURE CHANGES.
- ② - THIS DISTANCE FOR EXPANSION JOINTS HAVING SKEW ANGLES OF 15° OR LESS IS THE ACTUAL DISTANCE TO THE THERMAL NEUTRAL POINT OF THE SUPERSTRUCTURE ALONG THE CENTERLINE OF ROADWAY. THIS DISTANCE FOR EXPANSION JOINTS HAVING SKEW ANGLES OVER 15°, BUT NOT GREATER THAN 60° IS ARRIVED AT BY MULTIPLYING THE ABOVE DEFINED DISTANCE ALONG THE CENTERLINE OF ROADWAY BY THE COSINE OF THE EXPANSION JOINT SKEW ANGLE.
- ③ - THIS IS THE JOINT OPENING (DIMENSION "A") REQUIRED AT THE TIME OF ABUTMENT BACKWALL CONCRETE PLACEMENT, BASED ON THE DAY'S ANTICIPATED PEAK AMBIENT TEMPERATURE.
- ④ - MINIMUM JOINT OPENING (DIMENSION "A") AT THE TIME OF SEAL GLAND INSTALLATION SHALL NOT BE LESS THAN THE DIMENSION SHOWN ON SHEET [4/5]. IF THE JOINT OPENING IS LESS, INSTALLATION SHALL BE POSTPONED UNTIL THE TEMPERATURE DROPS A SUFFICIENT AMOUNT TO ALLOW THE MINIMUM JOINT INSTALLATION WIDTH (DIMENSION "A").

**EXAMPLE**

GIVEN - THE DISTANCE FROM THE CENTERLINE OF THE JOINT TO THE THERMAL NEUTRAL POINT OF THE SUPERSTRUCTURE ALONG THE CENTERLINE OF THE ROADWAY IS 287.5 FEET. THE SKEW ANGLE OF THE EXPANSION JOINT IS 30° AND THE ANTICIPATED AMBIENT TEMPERATURE AT THE TIME OF JOINT INSTALLATION IS 65° F.

FIND - THE REQUIRED STRIP SEAL GLAND SIZE AND THE JOINT OPENING (DIMENSION "A") AT THE TIME OF JOINT ARMOR INSTALLATION.

SOLUTION - (A) ENTER TABLE "A" AT ① WITH 287.5 FEET AND FIND THAT THE REQUIRED STRIP SEAL GLAND SIZE IS 4 INCHES.

(B) ENTER TABLE "C" AT ② WITH (287.5 FEET) x (COSINE OF 30°) = 248.98 FEET AND FIND THE REQUIRED JOINT OPENING AT 65° IS 1.86 INCHES.

NOTE: STEP (B) IS ONLY REQUIRED AT TIME OF CONSTRUCTION.

# GENERAL NOTES

**GENERAL:**

THIS STANDARD DRAWING PROVIDES DESIGN AND GENERAL CONSTRUCTION DETAILS. THE PROJECT PLANS SHALL LIST DIMENSION "A" FOR TEMPERATURES BETWEEN 30°F AND 90°F, OTHER PERTINENT DETAILS, AND SPECIAL NOTES THAT ARE SPECIFIC TO THE STRUCTURE.

**DESCRIPTION:**

PERFORM WORK IN ACCORDANCE WITH CMS 516 EXCEPT AS NOTED HEREIN.

**DESIGN DATA (STRIP SEAL SYSTEM):**

DESIGN LOADING: HL-93

**DESIGN STRESSES (ABUTMENT):**

EPOXY COATED REINFORCING STEEL - MIN. YIELD STRENGTH = 60 KSI

**NEOPRENE STRIP SEAL GLAND:**

FURNISH STRIP SEAL GLAND MEETING THE REQUIREMENTS OF ASTM D5973. PROVIDE TO THE ENGINEER SEVEN (7) DAYS BEFORE STARTING WORK, CERTIFIED TEST DATA CONFORMING TO CMS 101.03. ACCEPTANCE IS NOT REQUIRED.

LUBRICANT-ADHESIVE: USE A LUBRICANT-ADHESIVE TO INSTALL THE GLAND, PROVIDED BY THE MANUFACTURER OF THE NEOPRENE STRIP SEAL GLAND.

INSTALLATION: INSTALL STRIP SEAL EXPANSION JOINT SYSTEM AFTER ALL CORRECTIVE DECK WORK HAS BEEN COMPLETED, INCLUDING GRINDING.

**JOINTS IN NEOPRENE STRIP SEAL GLAND:**

FURNISH NEOPRENE STRIP SEAL GLAND IN ONE CONTINUOUS PIECE UNLESS OTHERWISE APPROVED BY THE ENGINEER.

**STEEL RETAINERS:**

FURNISH SOLID SHAPE STEEL RETAINERS, AS SHOWN IN DETAIL D, SHEET [3/5], THAT ARE EXTRUDED, HOT ROLLED OR MACHINED. RETAINERS MANUFACTURED FROM BENT PLATE OR BUILT-UP PIECES ARE NOT ACCEPTABLE. THE MANUFACTURER SHALL SPECIFY THE INTERNAL DIMENSIONS OF THE STEEL RETAINER TO ACHIEVE A POSITIVE SEAL AND ANCHORAGE.

AT JOINT UPTURNS, ESPECIALLY ON SKEWED BRIDGE DECKS, THE USE OF SPLIT RETAINERS MAYBE NECESSARY TO ENSURE PROPER NEOPRENE STRIP SEAL GLAND INSTALLATION. WHERE THE SPLIT RETAINERS ARE REQUIRED, THE MANUFACTURER SHALL OBTAIN THE ENGINEER'S ACCEPTANCE FOR THE DESIGN.

BEFORE NEOPRENE STRIP SEAL GLAND IS INSTALLED, CORRECT ANY DEFECT IN THE STEEL RETAINER OR THE ACTUAL STRIP SEAL EXPANSION JOINT THAT COULD CAUSE DAMAGE TO THE NEOPRENE STRIP SEAL GLAND.

**STEEL RETAINERS (CONT.):**

STRUCTURAL STEEL MATERIAL FOR STEEL RETAINERS SHALL BE ASTM A709, GRADE 36, 50, OR 50W.

**CLOSURE POURS:** THE CLOSURE POURS ALLOW FOR INSTALLATION OF THE EXPANSION JOINT SYSTEM AFTER THE CONCRETE RAILINGS AND SIDEWALK ARE INSTALLED.

FOR PROJECTS WITH INERTIAL PROFILING SURFACE SMOOTHNESS REQUIREMENTS, THE EXPANSION JOINT SYSTEM SHALL BE INSTALLED AFTER ALL SURFACE SMOOTHNESS CORRECTIVE WORK HAS BEEN PERFORMED.

FOR PROJECTS WITHOUT INERTIAL PROFILING SURFACE SMOOTHNESS REQUIREMENTS, THE CONCRETE RAILINGS AND SIDEWALK MAY BE COMPLETED WITHOUT CLOSURE POURS.

**JOINTS IN STEEL RETAINERS:**

WELDS SHALL BE WATER TIGHT, PARTIAL PENETRATION WELDS AROUND THE OUTER PERIPHERY OF THE ABUTTING SURFACES. GRIND FLUSH ALL WELDS IN CONTACT WITH THE NEOPRENE STRIP SEAL GLAND. DO NOT USE SHORT PIECES OF STEEL RETAINERS LESS THAN 6'-0" LONG, UNLESS REQUIRED AT CURBS OR SIDEWALKS. DO NOT PROVIDE ADDITIONAL SPLICES IN RETAINERS AT THE CURB OR SIDEWALK SECTIONS OTHER THAN THOSE DETAILED IN THE STANDARD BRIDGE DRAWINGS.

**STRIP SEAL EXPANSION JOINT COATING:**

COAT STEEL PARTS OF THE STRIP SEAL EXPANSION JOINT ASSEMBLY ACCORDING TO CMS 516.

**STEEL RETAINER TEMPORARY SUPPORTS:**

THE FABRICATOR SHALL DESIGN, PROVIDE, AND INSTALL TEMPORARY SUPPORTS TO RESIST SHIPPING, ERECTION, AND CONSTRUCTION FORCES WITHOUT DAMAGE TO THE STEEL RETAINERS OR COATING. THESE SUPPORTS SHALL BE ADJUSTABLE IN THE FIELD TO ACCOUNT FOR VARIABLE TEMPERATURE SETTINGS AND HEIGHT ADJUSTMENTS. INSTALL THE TEMPORARY SUPPORTS AFTER THE FABRICATION AND STRIP SEAL EXPANSION JOINT COATING IS COMPLETE.

**NOTES TO DESIGNER:**

PROJECT PLANS SHALL LIST DIMENSION "A" AS SHOWN IN SECTION A-A, SHEETS [1/5] AND [2/5] FOR TEMPERATURES BETWEEN 30°F AND 90°F IN 10°F INCREMENTS.

NEOPRENE STRIP SEAL GLAND AT FIXED BEARINGS SHALL BE THE SAME SIZE AS AT THE EXPANSION BEARINGS WITH A DIMENSION "A" OF 2 INCHES AT ANY AMBIENT TEMPERATURE.

LIMITATION: SKEW ANGLES SHALL NOT BE GREATER THAN 60°.