

PART PLAN AT ABUTMENT

FOR SQUARE OR LOW SKEWED (15° OR LESS) BRIDGES WITH DEFLECTOR PARAPET RAILING

(BR-1 RAILING IS SHOWN, SBR-1-13 SHALL BE SIMILAR)

FOR SECTION X-X SEE SHEET [2 / 5].

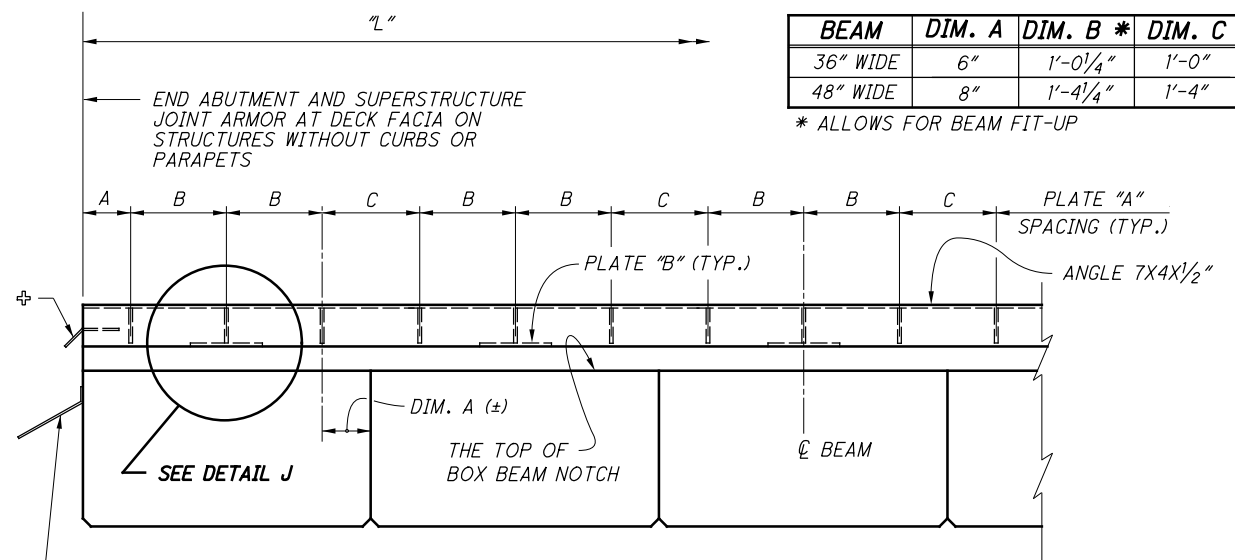

BEAM	DIM. A	DIM. B * DIM. C
36" WIDE	6"	1'-0 1/4" 1'-0"
48" WIDE	8"	1'-4 1/4" 1'-4"

* ALLOWS FOR BEAM FIT-UP

STAINLESS STEEL DEFLECTOR, REFER TO STANDARD BRIDGE DRAWING EXJ-3-82 FOR ALL PERTINENT INFORMATION.

NOTE: WHERE THE TOTAL WIDTH OUT TO OUT OF BOX BEAMS IS EQUAL TO THE BRIDGE ROADWAY WIDTH, JOINT ARMOR SHALL BE OF SUFFICIENT LENGTH TO ALLOW FOR FIT-UP OF BEAMS. SEE FORMULA FOR LENGTH "L".

L = LENGTH OF JOINT, EDGE TO EDGE OF DECK (FEET)
 $= [(N-1)(1/2) + N(W)] / (12 \cos \theta)$
 N = NUMBER OF BEAMS
 W = NOMINAL WIDTH OF BEAMS (INCHES)
 θ = SKEW ANGLE OF JOINT

END OF SUPERSTRUCTURE

WITHOUT CURBS OR PARAPETS

⊕ - STEEL DRIP STRIP. SEE STANDARD BRIDGE DRAWING. (NOT INCLUDED WITH EXPANSION JOINT FOR PAYMENT.)

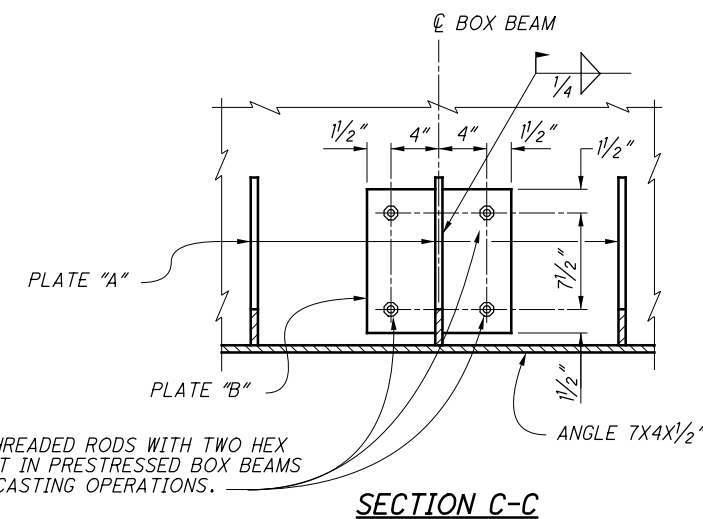

5/8" φ THREADED RODS WITH TWO HEX NUTS SET IN PRESTRESSED BOX BEAMS DURING CASTING OPERATIONS.

SECTION C-C

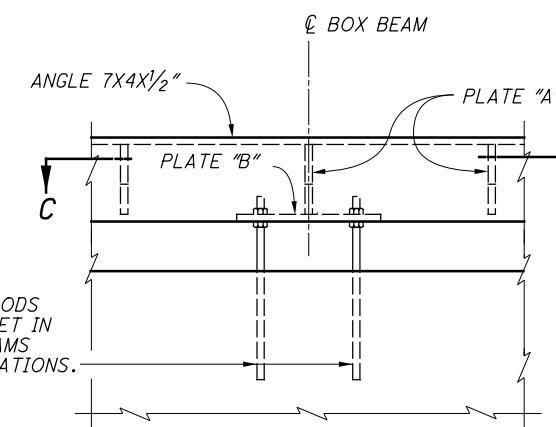

2 - 5/8" φ THREADED RODS WITH TWO HEX NUTS SET IN PRESTRESSED BOX BEAMS DURING CASTING OPERATIONS.

DETAIL J

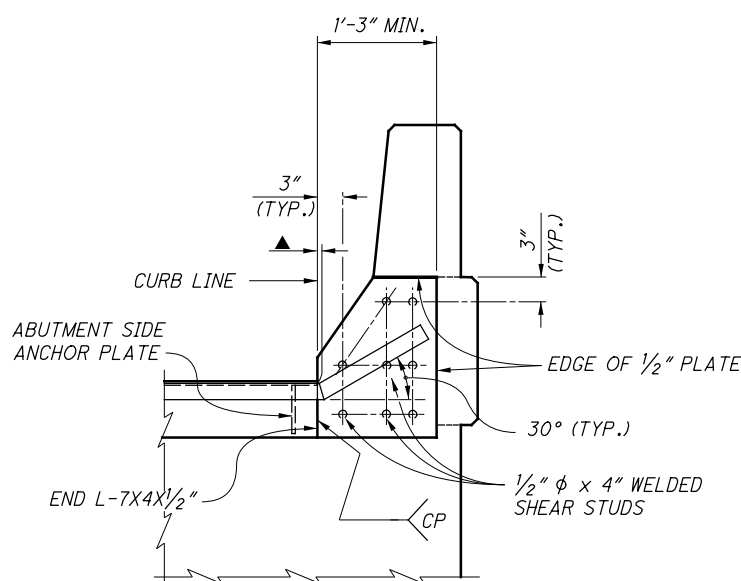

SECTION A-A

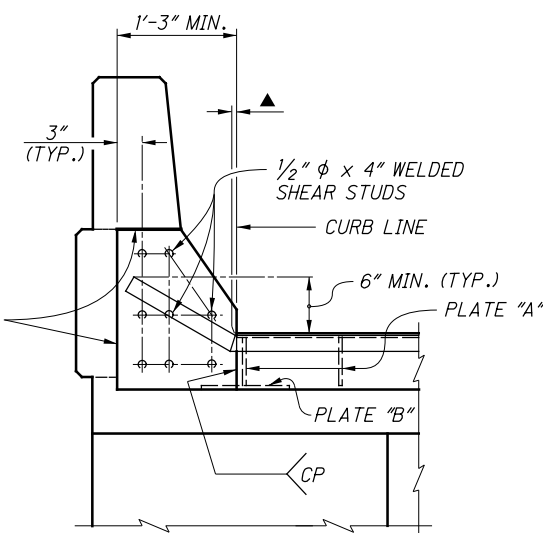

SECTION B-B

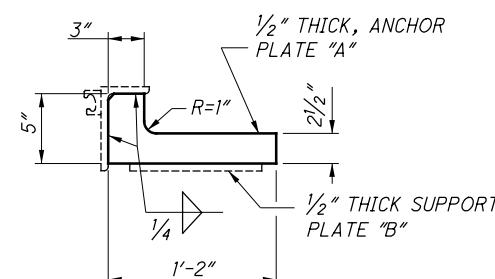

DETAIL OF PLATE "A"

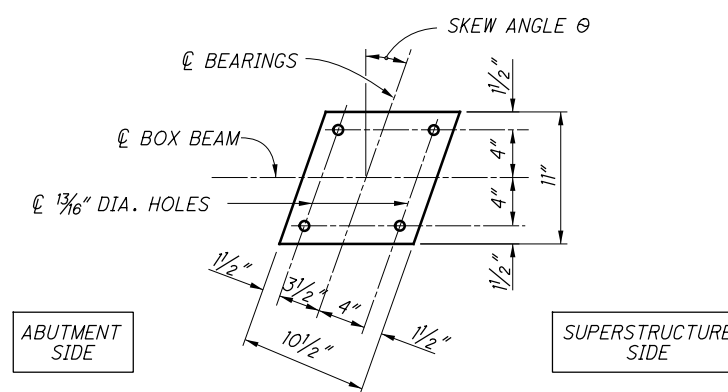

PLAN OF PLATE "B"

▲ - 0" MIN. TO 1/2" MAX. AT BREAKPOINT IN RETAINER FOR SQUARE BRIDGES. ON SKEWED BRIDGES THIS DIMENSION WILL ONLY APPLY TO THE SIDE OF JOINT ASSEMBLY WHICH IS NEAREST TO THE CURB LINE. (SEE SHEET [2 / 5].)

BEAM AGENCY: OFFICE OF STRUCTURAL ENGINEERING

STATE OF OHIO DEPARTMENT OF TRANSPORTATION
 01-20-94
 DATE

ENGINEER OF BRIDGES: [Signature]

DESIGNED	AJM	DESIGNED	AJM
CHECKED	JS	CHECKED	JS
REVIEWED	WTL/LMW	REVIEWED	WTL/LMW

EXJ-5-93

STANDARD STRIP SEAL EXPANSION JOINTS CONCRETE BOX BEAM STRUCTURES

1 / 5

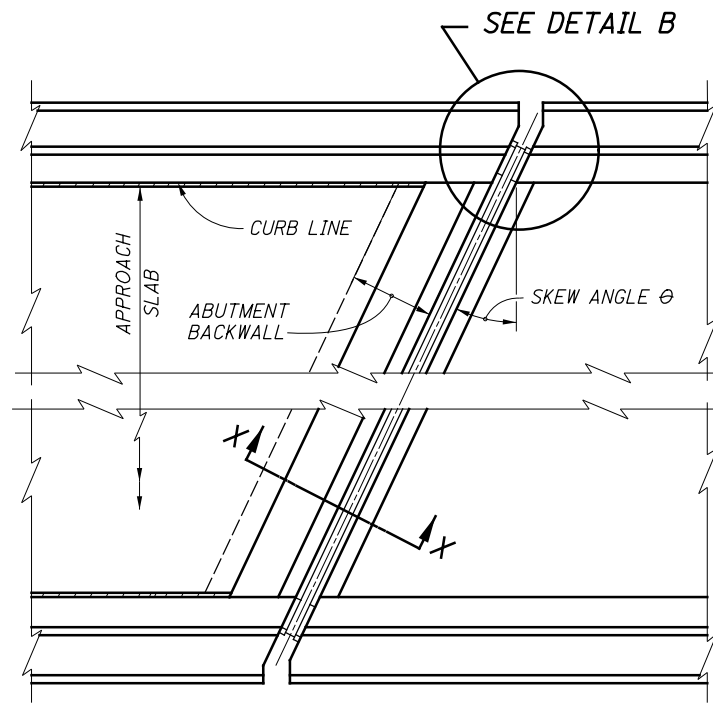

PLAN AT ABUTMENT

FOR SKEWED BRIDGES (OVER 15°)
WITH DEFLECTOR PARAPET RAILING

(BR-1 RAILING IS SHOWN, SBR-1-13 SHALL BE SIMILAR)

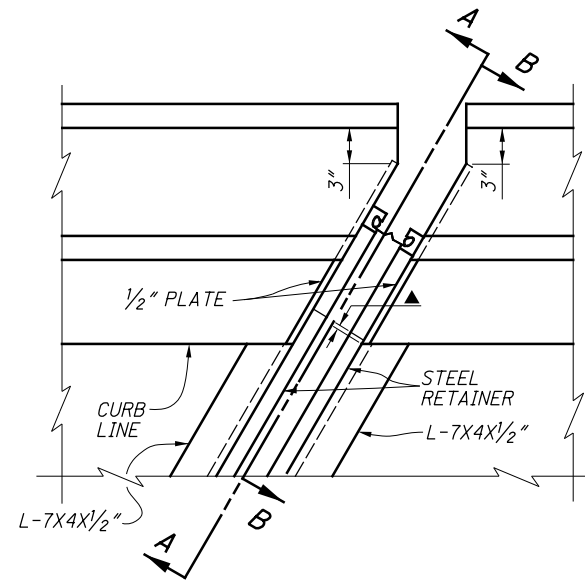

DETAIL B

SEE SHEET [1/5] FOR DEFINITION OF "A", SECTION A-A AND SECTION B-B. SECTION A-A AND SECTION B-B ARE SIMILAR FOR SQUARE AND SKEWED BRIDGES EXCEPT FOR THE CONCRETE FORMING AT THE EDGE OF THE PARAPET.

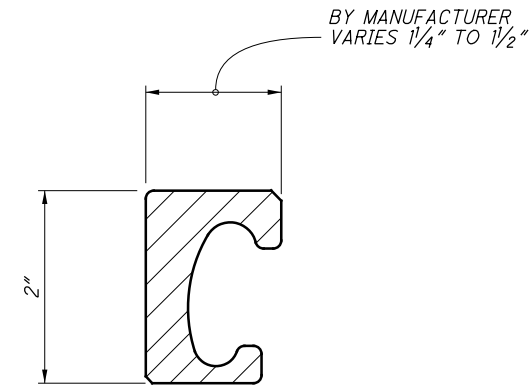

RETAINER DETAIL

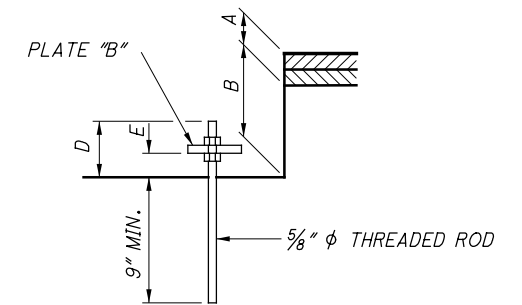

DETAIL K

A = ASPHALT CONCRETE WEARING SURFACE THICKNESS (OR COMPOSITE SLAB THICKNESS) AT NOTCH.
 B = 5" NOTCH FOR 17" BEAMS OR 7" NOTCH FOR 21" THRU 42" BEAMS.
 D = A + B - 4" (SHALL BE SHOWN ON THE PROJECT PLANS)
 E = A + B - 6" (IF DIM. "E" IS LESS THAN 3", A BED OF NON-SHRINK GROUT, CMS 705.22, SHALL BE PLACED AND COMPACTED UNDER EACH PLATE "B" AFTER FINAL VERTICAL ADJUSTMENT.)

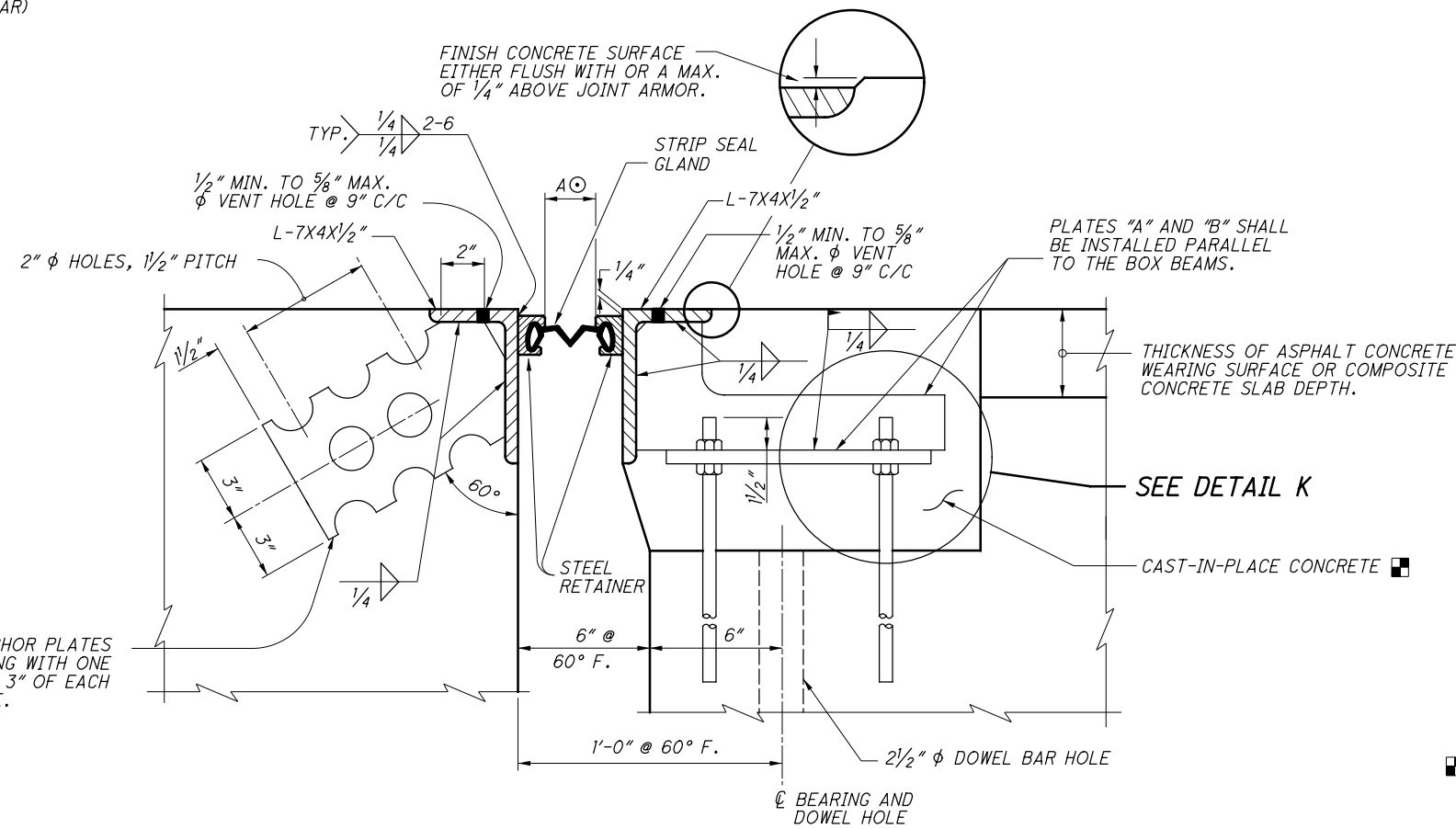

SECTION X-X

3/8" X 6" X 11" ANCHOR PLATES @ 1'-6" SPACING WITH ONE PLATE WITHIN 3" OF EACH END OF ANGLE.

⊙ - DIMENSION "A" SHALL BE DETERMINED FROM TABLE "B", TABLE "C" OR TABLE "D" ON SHEET [4/5].

SEE SHEET [1/5] FOR SECTION A-A AND B-B

■ - SURFACE TEXTURE ON DECK JOINTS SHALL BE PARALLEL WITH THE JOINT FOR SKEWED BRIDGES WITH ASPHALT CONCRETE WEARING SURFACE. THE CONCRETE MINIMUM COMPRESSIVE STRENGTH - 4.5 KSI.

DESIGN AGENCY	OFFICE OF STRUCTURAL ENGINEERING
STATE OF OHIO DEPARTMENT OF TRANSPORTATION	DATE 01-20-94
REVIEWED	WTL/LMW
CHECKED	JS
DESIGNED	AJM
REVISIONS	02-19-91 07-19-02 01-18-13 01-19-18
STANDARD	EXJ-5-93
STRIP SEAL EXPANSION JOINTS CONCRETE BOX BEAM STRUCTURES	
2	5

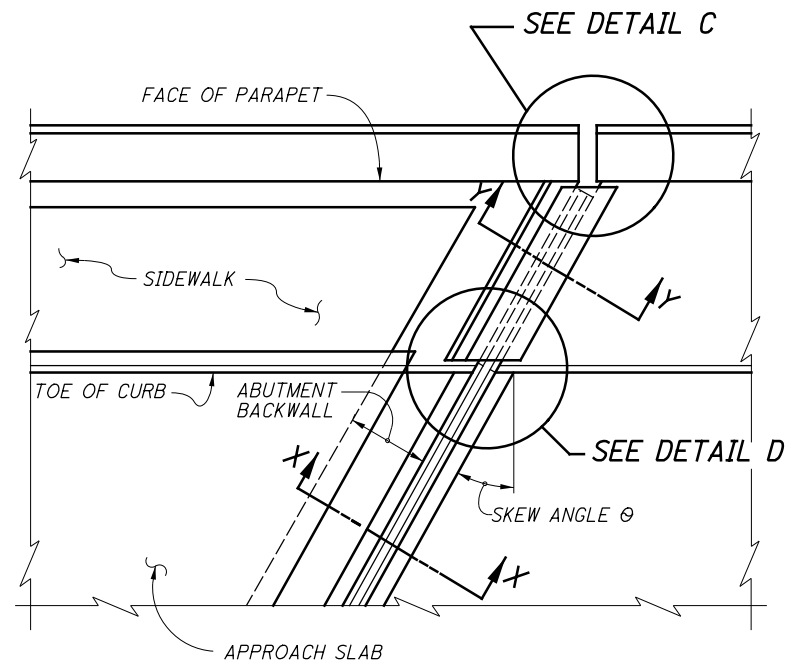

**PART PLAN AT ABUTMENT
FOR BRIDGES WITH SIDEWALK
PARAPET RAILING**

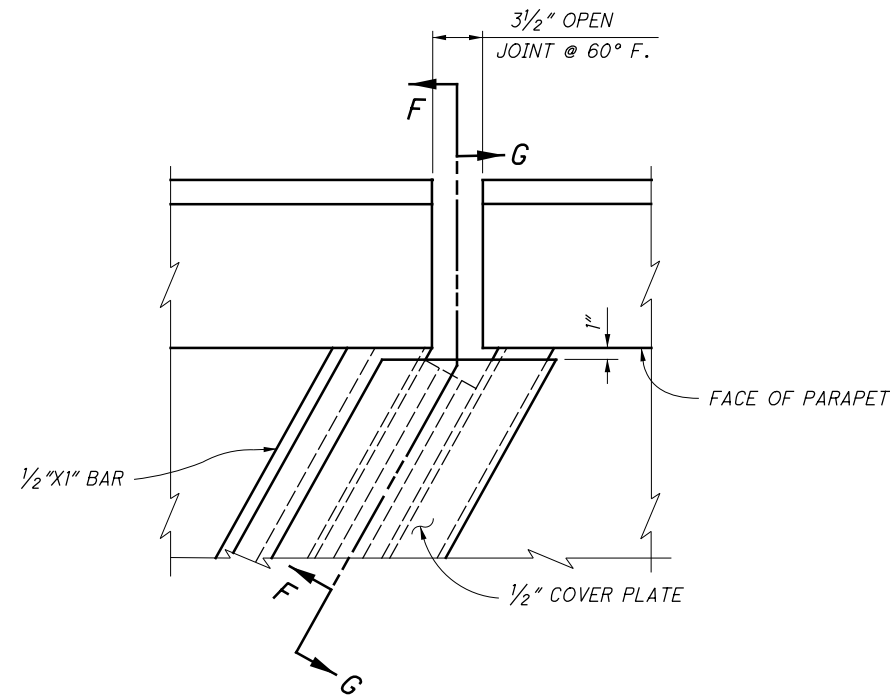

DETAIL C

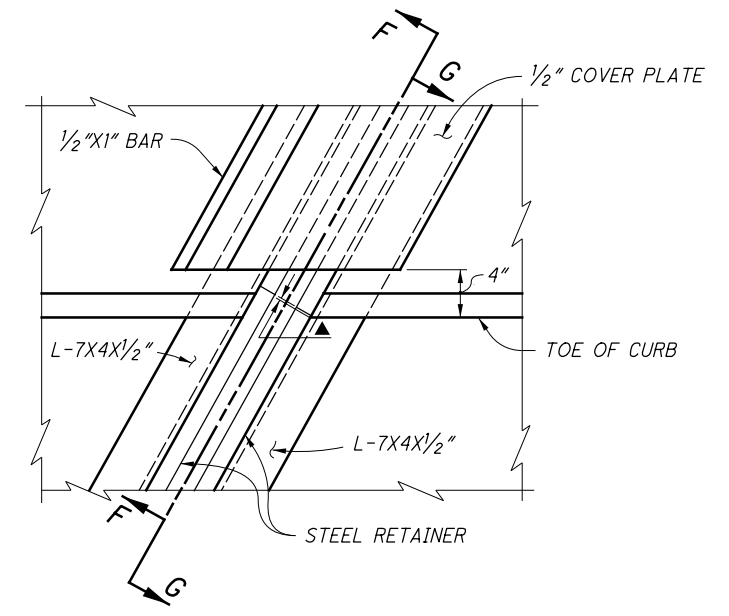

DETAIL D

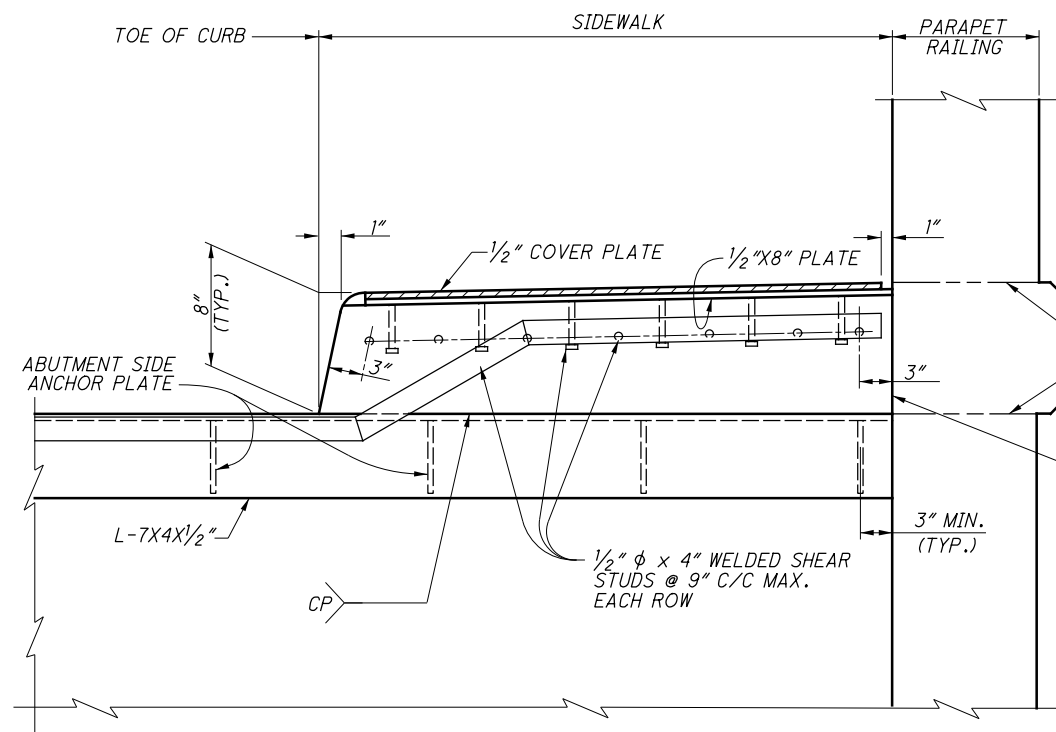

SECTION F-F

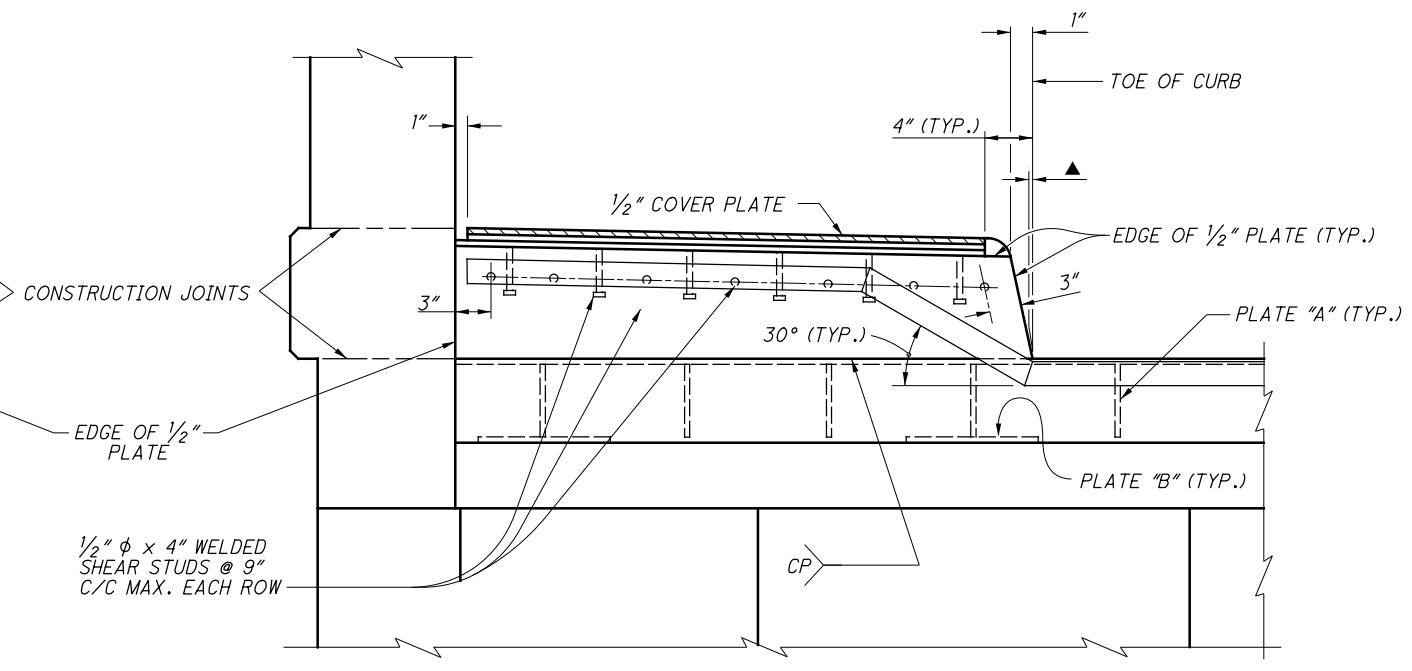

SECTION G-G

▲ - 0" MIN. TO 1/2" MAX. AT BREAKPOINT IN RETAINER FOR SQUARE BRIDGES. ON SKEWED BRIDGES THIS DIMENSION WILL ONLY APPLY TO THE SIDE OF JOINT ASSEMBLY WHICH IS NEAREST TO THE CURB LINE (SEE DETAIL "D" ABOVE).

FOR SECTION X-X SEE SHEET 2 / 5 .

FOR SECTION Y-Y SEE SHEET 4 / 5 .

DESIGNED AJM	CHECKED JS	REVIEWED WTL/LMW	DATE	OFFICE OF STRUCTURAL ENGINEERING
			01-20-94	
STATE OF OHIO DEPARTMENT OF TRANSPORTATION			ENGINEER OF BRIDGES	
REVISIONS				
02-20-91				
07-19-02				
01-18-13				
01-19-18				
STRIP SEAL EXPANSION JOINTS CONCRETE BOX BEAM STRUCTURES			EXJ-5-93	
STANDARD				
				3 / 5

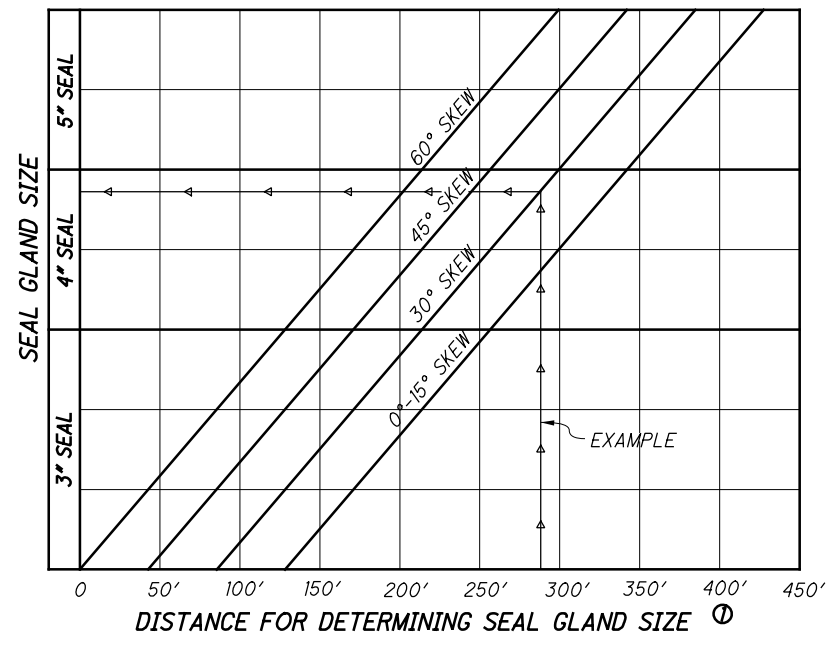

TABLE A

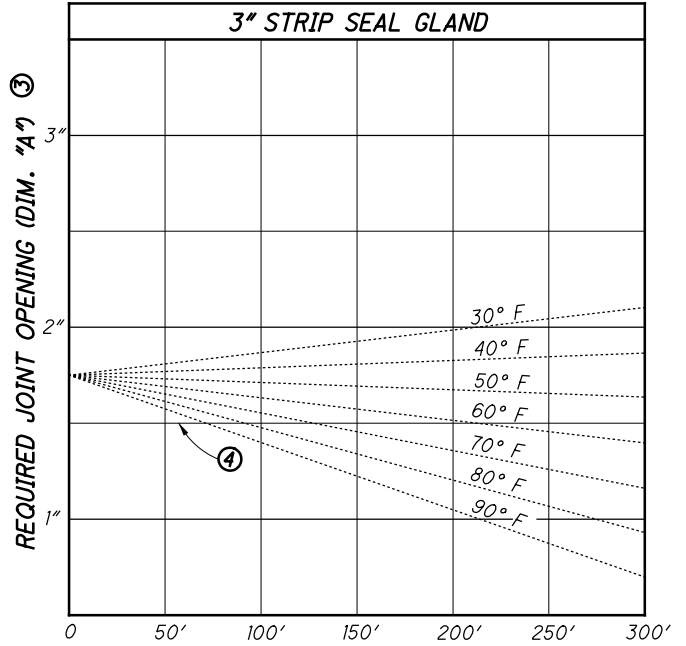

TABLE B

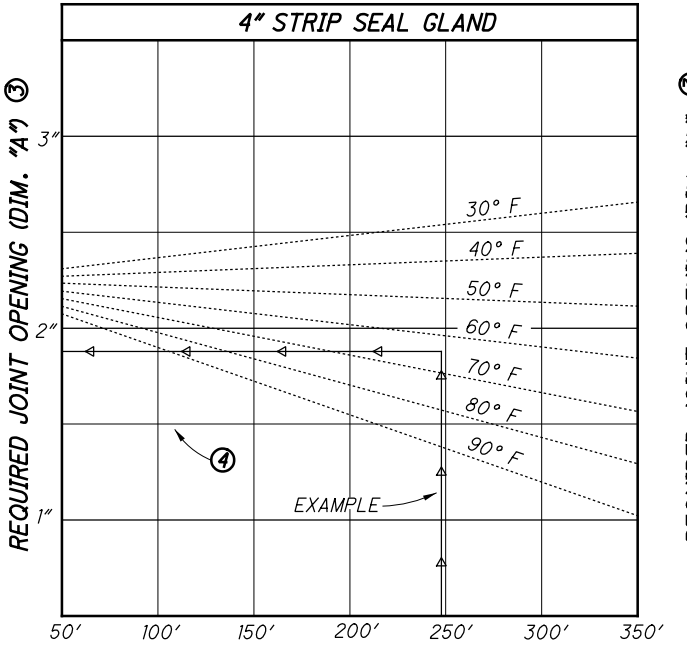

TABLE C

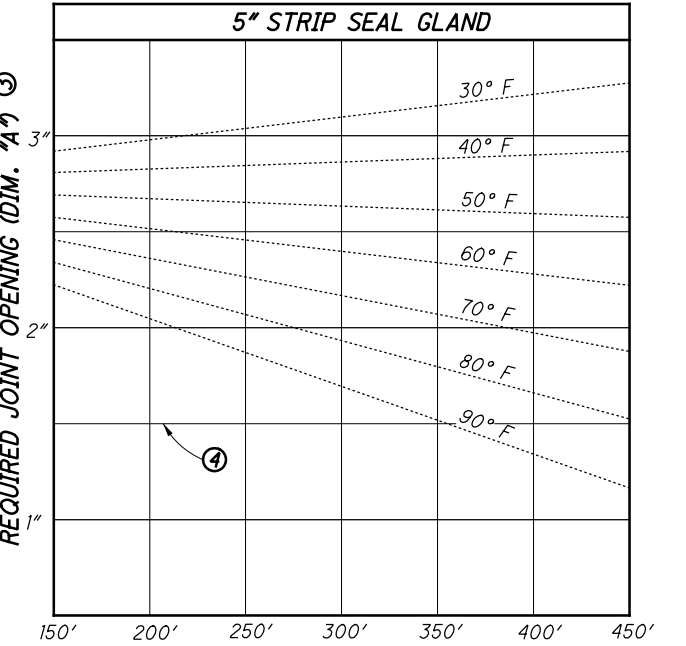

TABLE D

LEGEND

- ① - THIS IS THE ACTUAL DISTANCE FROM THE CENTERLINE OF JOINT TO THE THERMAL NEUTRAL POINT OF THE SUPERSTRUCTURE MEASURED ALONG THE CENTERLINE OF ROADWAY. THIS DIMENSION SHALL BE A MAXIMUM OF 299' FOR 60° SKEWS, 342' FOR 45° SKEWS, 385' FOR 30° SKEWS AND 427' FOR 0° THRU 15° SKEWS. THE THERMAL NEUTRAL POINT OF THE SUPERSTRUCTURE IS THAT POINT WHICH HAS ZERO HORIZONTAL MOVEMENT DURING TEMPERATURE CHANGES.
- ② - THIS DISTANCE FOR EXPANSION JOINTS HAVING SKEW ANGLES OF 15° OR LESS IS THE ACTUAL DISTANCE TO THE THERMAL NEUTRAL POINT OF THE SUPERSTRUCTURE ALONG THE CENTERLINE OF ROADWAY. THIS DISTANCE FOR EXPANSION JOINTS HAVING SKEW ANGLES OVER 15° BUT NOT GREATER THAN 60° IS ARRIVED AT BY MULTIPLYING THE ABOVE DEFINED DISTANCE ALONG THE CENTERLINE OF ROADWAY BY THE COSINE OF THE EXPANSION JOINT SKEW ANGLE.
- ③ - THIS IS THE JOINT OPENING (DIMENSION "A") REQUIRED AT THE TIME OF ABUTMENT BACKWALL CONCRETE PLACEMENT, BASED ON THE DAY'S ANTICIPATED PEAK AMBIENT TEMPERATURE.
- ④ - MINIMUM JOINT OPENING (DIMENSION "A") AT TIME OF SEAL GLAND INSTALLATION SHALL NOT BE LESS THAN 1/2". IF THE JOINT OPENING IS LESS, INSTALLATION SHALL BE POSTPONED UNTIL THE TEMPERATURE DROPS A SUFFICIENT AMOUNT TO ALLOW THE MINIMUM 1/2" OPENING.

EXAMPLE

GIVEN - THE DISTANCE FROM THE CENTERLINE OF THE JOINT TO THE THERMAL NEUTRAL POINT OF THE SUPERSTRUCTURE ALONG THE CENTERLINE OF THE ROADWAY IS 287.5'. THE SKEW ANGLE OF THE EXPANSION JOINT IS 30° AND THE ANTICIPATED AMBIENT TEMPERATURE AT TIME OF JOINT INSTALLATION IS 65° F.

FIND - REQUIRED STRIP SEAL GLAND SIZE AND THE JOINT OPENING (DIMENSION "A") AT THE TIME OF JOINT ARMOR INSTALLATION.

SOLUTION -

(A) ENTER TABLE "A" AT ① WITH 287.5' AND FIND THAT THE REQUIRED STRIP SEAL GLAND SIZE IS 4 INCHES.

(B) ENTER TABLE "C" AT ② WITH 287.5' X COSINE OF 30° = 248.98' AND FIND REQUIRED JOINT OPENING AT 65°F IS 1.86".

NOTE: STEP (B) REQUIRED ONLY AT TIME OF CONSTRUCTION.

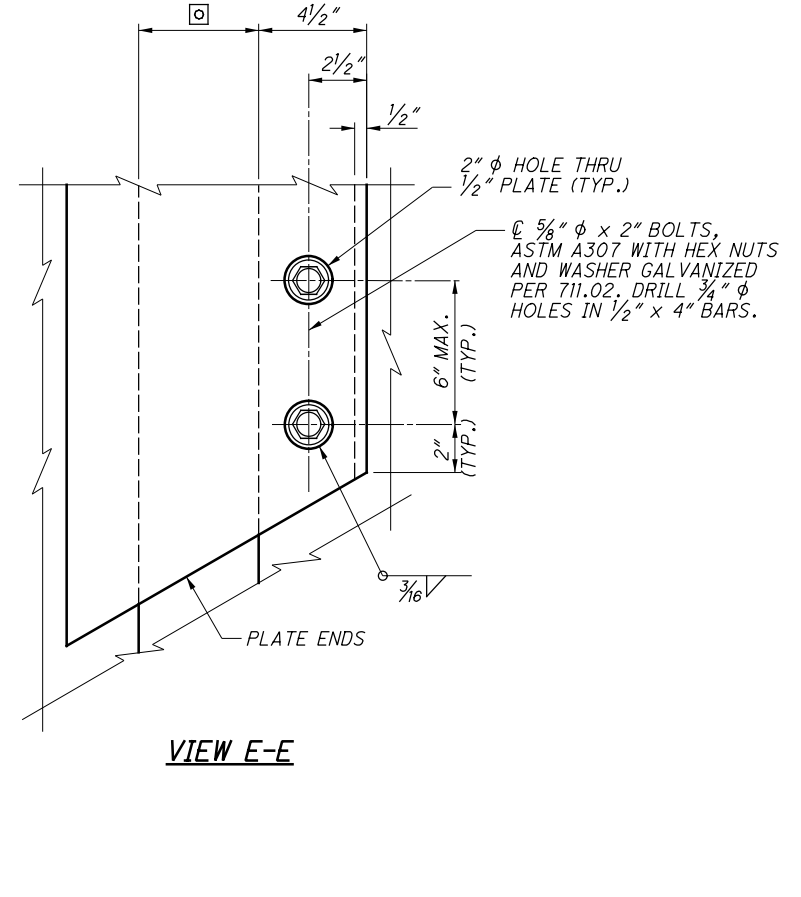
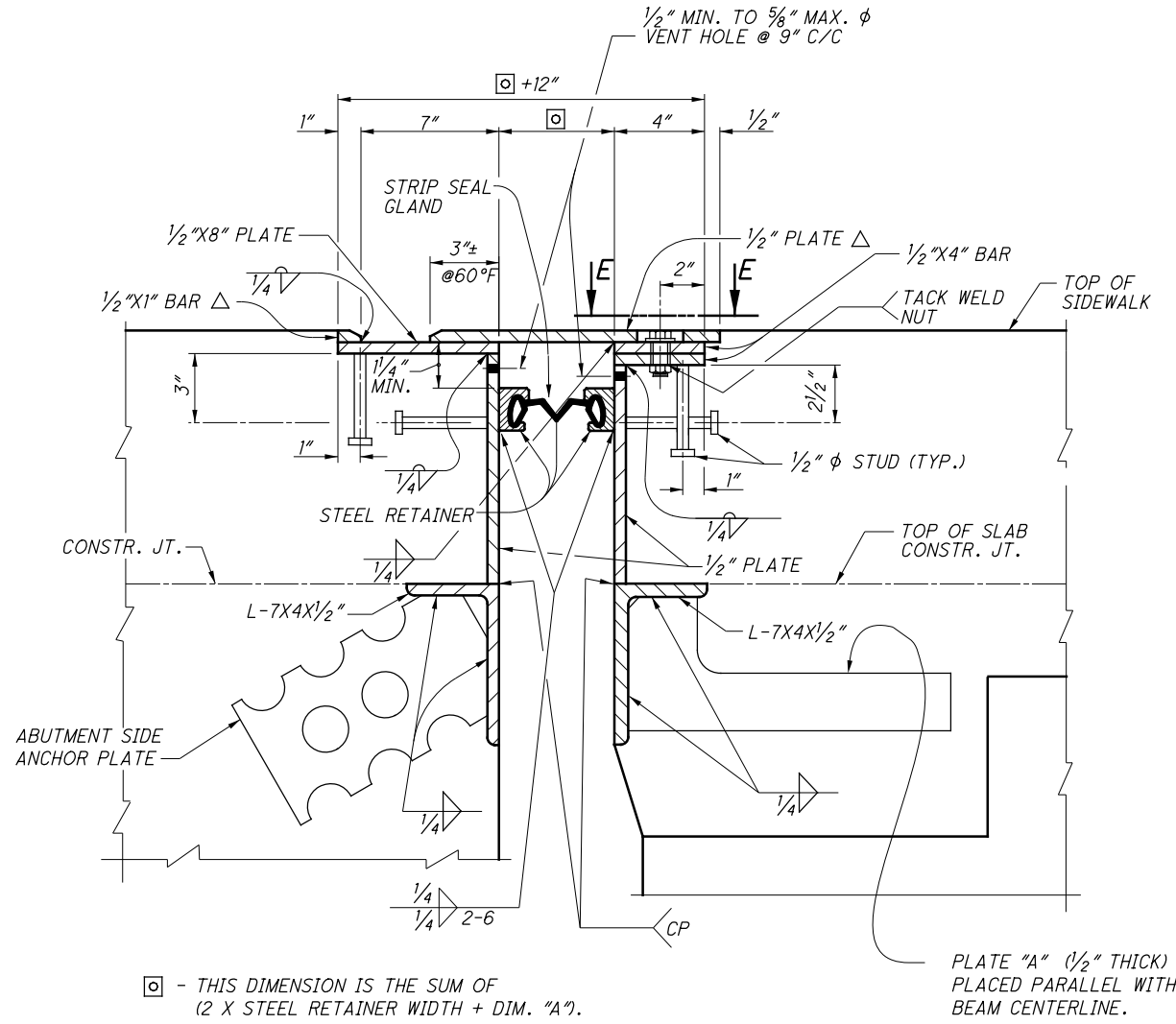

⊠ - THIS DIMENSION IS THE SUM OF (2 X STEEL RETAINER WIDTH + DIM. "A").

Δ - PROVIDE A 1/2" HORIZONTAL x 1/4" VERTICAL BEVEL AT THE EXPOSED EDGE OF THE 1/2" COVER PLATE AND 1/2" X 1" BAR

SECTION Y-Y

GENERAL NOTES:

STRIP SEAL: FURNISH EXTRUDED POLYCHLOROPRENE MATERIAL CONFORMING TO ASTM D2628. DUE TO THE CONFIGURATION OF THE SEAL, THE RECOVERY TEST IS NOT APPLICABLE. THE PHYSICAL PROPERTIES OF THE STRIP SEAL SHALL CONFORM TO TABLE "E".

THE MANUFACTURER OR AN ACCREDITED LABORATORY SHALL TEST EACH LOT AS SPECIFIED AND SUBMIT TWO COPIES OF CERTIFIED TEST DATA SHOWING COMPLIANCE TO THE ODOT OFFICE OF MATERIALS MANAGEMENT. THE SEAL AND RETAINER ARE AN INTEGRAL SYSTEM DESIGNED AND SUPPLIED BY THE SAME MANUFACTURER. SEE "CONSTRUCTION PROCEDURE" FOR INSTALLATION.

TABLE E (PHYSICAL PROPERTIES OF SEAL ELEMENT)		
PROPERTY	REQUIREMENT	ASTM METHOD
TENSILE STRENGTH, MIN. PSI	2000	D412
ELONGATION @ BREAK, MIN. (PERCENT)	250	D412
HARDNESS, TYPE A DUROMETER, POINTS	60 ± 5	MODIFIED D2240
OVEN AGING, 70 HR @ 212°F TENSILE STRENGTH, LOSS, MAX. ELONGATION, LOSS, MAX. HARDNESS, TYPE A DUROMETER, POINTS CHANGE	20 PERCENT 20 PERCENT 0 TO +10	D573 MODIFIED D2240
OIL SWELL, ASTM OIL 3 70 HR @ 212°F, WEIGHT CHANGE MAX	45 PERCENT	D471
OZONE RESISTANCE 20 PERCENT STRAIN, 300 PPHM IN AIR, 70 HR @ 104°F (WIPED WITH TOLUENE TO REMOVE SURFACE CONTAMINATION)	NO CRACKS	D1149
LOW TEMPERATURE STIFFENING 7 DAYS @ 14°F HARDNESS, TYPE A DUROMETER, POINTS CHANGE COMPRESSION SET, 70 HR @ 212°F MAX.	0 TO +15 40 PERCENT	D2240 MODIFIED D2240 D395 METHOD B

LUBRICANT-ADHESIVE: FURNISH A ONE PART MOISTURE CURING POLYURETHANE COMPOUND MEETING THE REQUIREMENTS OF ASTM D4070 AND AS SPECIFIED BY THE SEAL MANUFACTURER. SEE "CONSTRUCTION PROCEDURE" FOR APPLICATION.

JOINTS IN STRIP SEALS: FURNISH SEALS IN ONE CONTINUOUS PIECE UNLESS OTHERWISE APPROVED BY THE ENGINEER.

SEAL RETAINERS: FURNISH SOLID SHAPE STEEL RETAINERS, AS DIMENSIONED ON SHEET 2 OF 5 "RETAINER DETAIL", THAT ARE EXTRUDED, HOT ROLLED OR MACHINED. RETAINERS MANUFACTURED FROM BENT PLATE OR BUILT UP PIECES ARE NOT ACCEPTABLE. THE MANUFACTURER SHALL SPECIFY THE INTERNAL DIMENSIONS OF THE RETAINER TO ACHIEVE A POSITIVE SEAL AND ANCHORAGE.

AT JOINT UPTURNS, ESPECIALLY ON SKEWED BRIDGE DECKS, THE USE OF SPLIT RETAINERS MAY BE NECESSARY TO ENSURE PROPER SEAL GLAND INSTALLATION. WHERE THE SPLIT RETAINERS ARE REQUIRED, THE MANUFACTURER SHALL OBTAIN THE ENGINEER'S APPROVAL FOR THE DESIGN.

BEFORE THE GLAND IS INSTALLED, CORRECT ANY DEFECTS IN THE STEEL RETAINER OR THE ACTUAL EXPANSION JOINT THAT COULD CAUSE DAMAGE TO THE GLAND.

JOINTS IN RETAINERS: WELDS SHALL BE WATER TIGHT, PARTIAL PENETRATION WELDS AROUND THE OUTER PERIPHERY OF THE ABUTTING SURFACES. GRIND FLUSH ALL WELDS IN CONTACT WITH THE SEAL AND JOINT ARMOR. DO NOT USE SHORT PIECES OF RETAINERS LESS THAN 6'-0" LONG, UNLESS REQUIRED AT CURBS OR SIDEWALKS. DO NOT PROVIDE ADDITIONAL SPLICES IN RETAINERS AT CURB OR SIDEWALK SECTIONS OTHER THAN THOSE DETAILED IN THE STANDARD BRIDGE DRAWINGS.

ARMOR STEEL: ALL ANGLE SHAPES SHALL BE ASTM A709, GRADE 50 OR 50W. ALL OTHER STEEL PARTS INCLUDING RETAINERS, SHALL BE ASTM A709, GRADE 36, 50 OR 50W.

JOINTS IN ARMOR STEEL: SHOP OR FIELD JOINTS IN THE ARMOR SHALL BE COMPLETE PENETRATION WELDS GROUND FLUSH WHERE IN CONTACT WITH THE RETAINER.

ARMOR COATING: COAT ALL STEEL PARTS OF THE JOINT ASSEMBLY ACCORDING TO 516.

TEMPORARY SUPPORTS: THE FABRICATOR SHALL DESIGN AND INSTALL TEMPORARY SUPPORTS TO RESIST SHIPPING, ERECTION AND CONSTRUCTION FORCES WITHOUT DAMAGE TO THE STEEL ARMOR OR COATING. THESE SUPPORTS SHALL BE ADJUSTABLE IN THE FIELD TO ACCOUNT FOR VARIABLE TEMPERATURE SETTINGS. INSTALL THE SUPPORTS AFTER THE FABRICATION AND COATING IS COMPLETE.

NON-SHRINKING GROUT: FURNISH MATERIAL CONFORMING TO 705.22. LIMIT THE BATCH SIZE SUCH THAT PLACEMENT CAN BE COMPLETED WITHIN 30 MINUTES. DO NOT USE MORTAR OLDER THAN 30 MINUTES. DO NOT ADD WATER TO INCREASE FLOWABILITY WHICH HAS BEEN DECREASED BY DELAYED USE OF MORTAR. INCLUDE WITH SUPERSTRUCTURE CONCRETE FOR PAYMENT.

THREADED RODS: FURNISH 5/8" DIAMETER THREADED RODS AND NUTS CONFORMING TO ASTM A307 OR A709, GRADE 36. GALVANIZE ACCORDING TO 711.02. INCLUDE WITH THE BOX BEAMS FOR PAYMENT.

BASIS OF PAYMENT: THE DEPARTMENT WILL PAY FOR CONCRETE PLACED IN THE BOX BEAM NOTCH SEPARATELY UNDER ITEM 511.

CONSTRUCTION PROCEDURE:

ARMOR INSTALLATION:

1. PLACE JOINT ASSEMBLY SO THE TWO (2) L7x4x1/2" ANGLES REMAIN PARALLEL TO EACH OTHER AND PERPENDICULAR TO THE ROADWAY GRADIENT.
2. FOR STRUCTURES WITH A COMPOSITE CONCRETE WEARING SURFACE, PLACE THE SUPERSTRUCTURE CONCRETE IN THE SPAN ADJACENT TO THE ABUTMENT PRIOR TO THE PLACEMENT OF ABUTMENT BACKWALL CONCRETE.
3. SET ABUTMENT EXPANSION JOINT WIDTH TO DIMENSION "A" NO MORE THAN FOUR HOURS PRIOR TO THE DAY'S PEAK AMBIENT TEMPERATURE. SEE PROJECT PLANS FOR DIMENSION "A".
4. PLACE THE BACKWALL CONCRETE DURING STABLE OR RISING AMBIENT TEMPERATURES. CONCLUDE PLACEMENT AT OR IMMEDIATELY BEFORE THE DAY'S PEAK AMBIENT TEMPERATURE.
5. HAND PLACE AND VIBRATE CONCRETE UNDER JOINT ARMOR TO ACHIEVE COMPLETE CONSOLIDATION.
6. LOOSEN ANY TEMPORARY JOINT ARMOR SUPPORTS AFTER INITIAL SET OF THE CONCRETE, PREFERABLY NOT LATER THAN TWO HOURS AFTER CONCLUSION OF THE CONCRETE PLACEMENT.
7. FOR STRUCTURES WITH A NON-COMPOSITE ASPHALT WEARING SURFACE, PLACE THE CONCRETE IN THE BOX BEAM NOTCH ACCORDING TO STEP 5 AFTER THE BACKWALL CONCRETE HAS BEEN PLACED. TEXTURE THE SURFACE PARALLEL TO THE JOINT. CONCRETE MIN. COMPRESSIVE STRENGTH - 4.5 KSI

SEAL INSTALLATION:

1. EXAMINE THE RETAINER FOR SOILAGE OR DEFECTS THAT CAN DAMAGE THE SEAL PRIOR TO SEAL INSTALLATION. REPAIR DEFECTS.
2. NOT MORE THAN 24 HOURS PRIOR TO SEAL INSTALLATION, BLAST THE RETAINER INTERIOR PER SSPC SP6 "COMMERCIAL BLAST CLEANING", WITHOUT DAMAGING ADJACENT COATINGS. REMOVE ALL BLASTING MEDIA FROM THE RETAINER.
3. CLEAN ALL SURFACES OF THE SEAL WITH METHYL ETHYL KETONE (MEK), TOLUENE (T) OR OTHER MANUFACTURER SPECIFIED SOLVENT USING CLEAN DISPOSABLE CLOTHS. MAINTAIN THE SURFACE CLEANLINESS UNTIL INSTALLATION.
4. IMMEDIATELY BEFORE APPLYING THE LUBRICANT-ADHESIVE, BONDING SURFACES MUST BE CLEAN, DRY AND WARMER THAN 45°F. BONDING SURFACES MUST BE MAINTAINED IN THIS CONDITION UNTIL THE SEAL IS INSTALLED. LIBERALLY APPLY THE LUBRICANT-ADHESIVE TO BOTH THE RETAINER AND THE SEAL USING THE MANUFACTURER'S SPECIFIED METHODS FOR COMPLETE AND UNIFORM COVERAGE.
5. INSTALL THE SEAL WITH EQUIPMENT AND PROCEDURE SPECIFIED BY THE MANUFACTURER. ELONGATION OF THE SEAL OR STRUCTURAL DAMAGE TO THE SEAL CAUSED BY INSTALLATION METHODS WILL BE CAUSE FOR REJECTION.
6. REMOVE EXCESS LUBRICANT-ADHESIVE AFTER INSTALLATION.

DESIGNER NOTES:

PROJECT PLANS SHALL LIST DIMENSION "A" FOR TEMPERATURES BETWEEN 30°F AND 90°F IN 10° INCREMENTS.

THE DESIGNER SHALL SUPPLY DETAILS FOR STRUCTURES WITH ROADWAY GRADES GREATER THAN 2%.

ANCHOR BAR HOLES IN ABUTMENT SEATS SHALL BE 2" Ø UNLESS OTHERWISE SHOWN IN THE CONTRACT CRITERIA/PLANS.

JOINT SEAL GLAND AT FIXED BEARINGS SHALL BE THE SAME SIZE AS AT THE EXPANSION BEARINGS WITH A DIMENSION "A" = 2" AT ANY AMBIENT TEMPERATURE.

PRESTRESSED CONCRETE BOX BEAMS SHALL BE MODIFIED AS FOLLOWS FOR STRIP SEAL INSTALLATION:

1. STIRRUP REINFORCING STEEL IN NOTCHED AREAS AT ENDS OF COMPOSITE BEAMS SHALL NOT PROJECT ABOVE THE TOP OF CONCRETE.
2. ENDS OF FASCIA BEAMS SHALL BE NOTCHED FULL WIDTH OF BEAMS.
3. 12 INCH DEEP BEAMS REQUIRE A SPECIAL DESIGN.
4. HOLES FOR ANCHOR BARS SHALL BE 2 1/2" DIAMETER.
5. BEAM ENDS FOR STRUCTURES ON GRADES OVER 2% SHALL BE MADE VERTICAL.

STATE OF OHIO DEPARTMENT OF TRANSPORTATION
01-20-94
DATE

OFFICE OF
STRUCTURAL ENGINEERING

REVISIONS
02-20-91
07-19-02
01-18-13
01-19-18

DESIGNED
AJM
BY
AJM

CHECKED
JS

REVIEWED
WTL/LMW
EXJ-5-93

STRIP SEAL EXPANSION JOINTS
CONCRETE BOX BEAM STRUCTURES