

ELEVATION

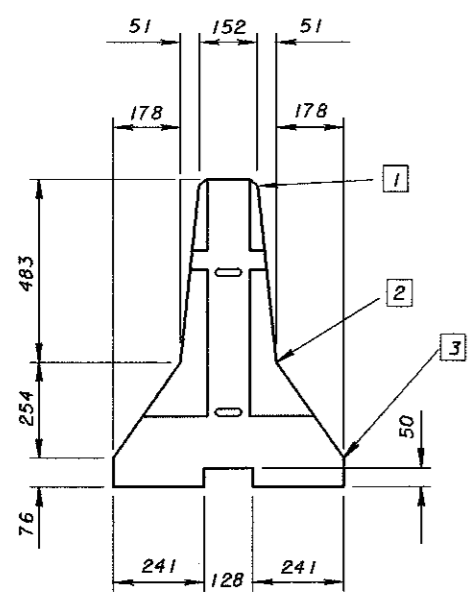

- 1 25 mm RADIUS OR 19 mm CHAMFER, ALL TOP AND END CORNERS.
- 2 PERMISSIBLE 250 mm RADIUS.
- 3 PERMISSIBLE 25 mm RADIUS.

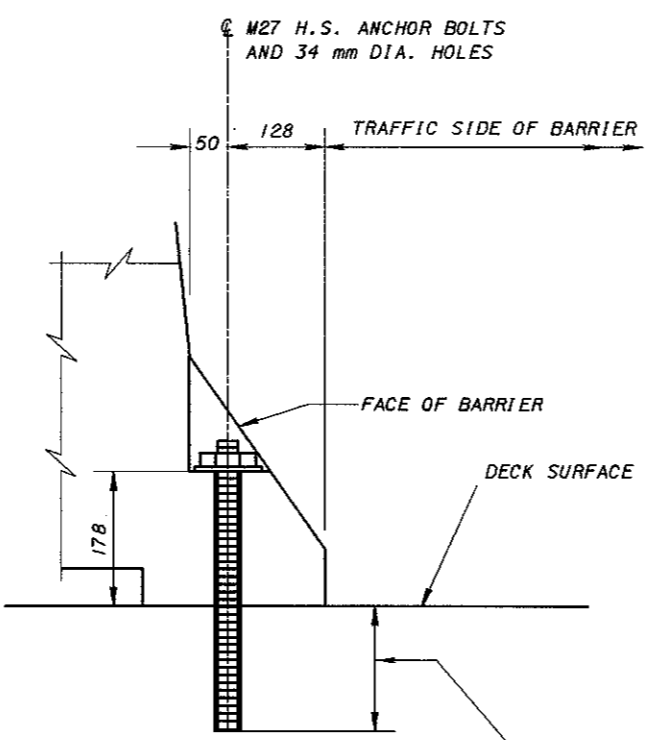
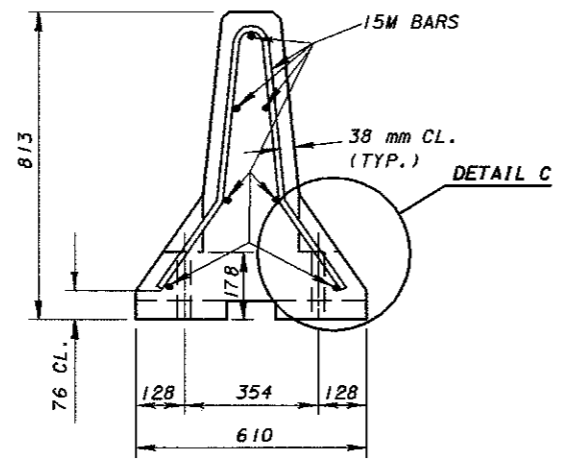

ANCHORS SHALL BE THROUGH BOLTS OR APPROVED RESIN ANCHORS. WHEN RESIN ANCHORS ARE USED THEY MUST BE EMBEDDED A MINIMUM OF 165 mm INTO FIRM CONCRETE. WHEN NO LONGER NEEDED, ANCHORS SHALL BE REMOVED AS DIRECTED BY THE ENGINEER. WHERE DECK IS TO REMAIN, HOLES SHALL BE FILLED WITH AN EPOXY NON-SHRINK GROUT.

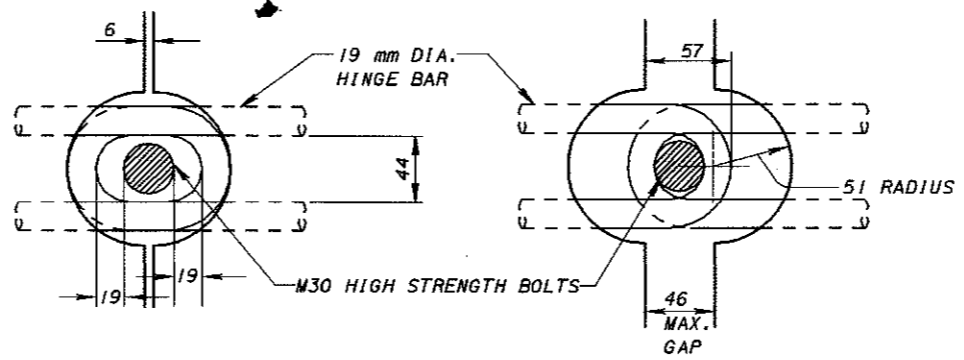

- 1 BARRIER SHALL INITIALLY BE PLACED CLOSER TOGETHER SO BOLTS CAN BE EASILY INSERTED THROUGH HINGE BAR LOOPS.
- 2 BARRIER JOINTS SHALL BE FULLY OPEN BEFORE NUT IS TIGHTENED ONTO BOLT AND OPENING IS SNUGGLY BLOCKED.

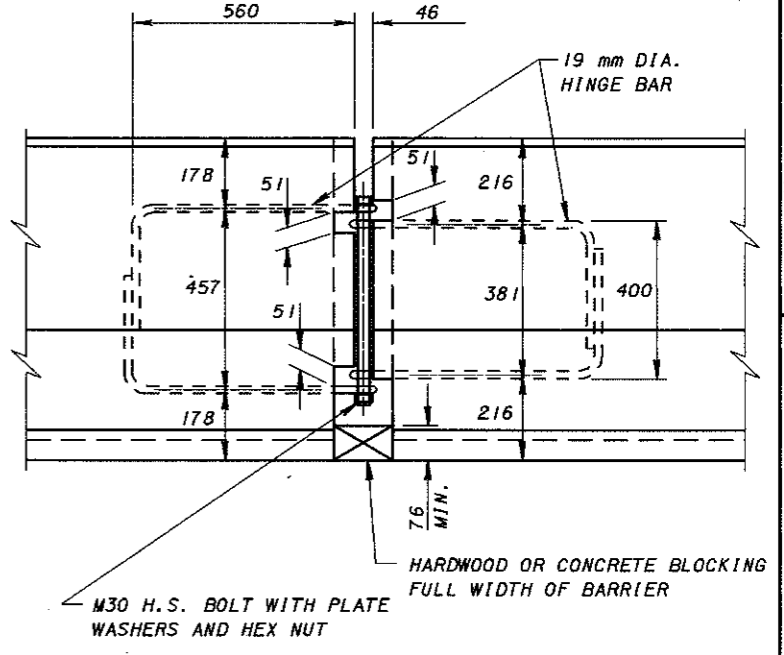

GENERAL NOTES

HARDWARE:
BOLTS, DECK ANCHORING BOLTS AND ALL NUTS AND WASHERS SHALL CONFORM TO ASTM A325M. THEY SHALL BE GALVANIZED IN ACCORDANCE WITH CMS 711.02.

ANCHORS:
ONCE ALL BARRIER SECTIONS HAVE BEEN PROPERLY SECURED, ANY PORTION OF AN ANCHOR THAT PROTRUDES BEYOND THE FACE OF THE BARRIER SHALL BE REMOVED.

REINFORCING STEEL:
ALL REINFORCING STEEL (INCLUDING THE 19 mm DIAMETER HINGE BARS) SHALL MEET THE REQUIREMENTS OF CMS 509.02. HINGE BARS SHALL BE GALVANIZED AFTER FABRICATION.

CONCRETE:
PORTABLE CONCRETE BARRIER SEGMENTS SHALL BE CONSTRUCTED OF CLASS C CONCRETE WITH A MINIMUM COMPRESSIVE STRESS OF 28 MPa.

BRIDGE DECK SURFACE PREPARATION:
THE SURFACE AREA ON WHICH THE PORTABLE CONCRETE BARRIER WILL REST SHALL BE CLEAR OF ALL LOOSE SAND, GRAVEL, DIRT AND DEBRIS.

MARKS:
ALL BARRIER SEGMENTS SHALL BE CLEARLY MARKED, WHERE "XX" IS THE YEAR IN WHICH THE BARRIER WAS CAST. EACH SHALL ALSO HAVE, ON IT'S TOP SURFACE, A UNIQUE IDENTIFICATION OF THE MANUFACTURER AND, SOMEWHERE ON THE BARRIER, THE DAY AND MONTH THE BARRIER WAS CAST.

ANY IRREGULARITIES IN THE BRIDGE DECK AREAS, UNLESS JUDGED BY THE ENGINEER TO BE INCONSEQUENTIAL, SHALL BE LEVELED WITH GROUT AND/OR ASPHALT.

ASPHALT ROLL ROOFING SHALL BE PLACED ON THOSE BRIDGE DECK AREAS, AS JUDGED BY THE ENGINEER, TO HAVE A SURFACE ROUGHNESS WHICH WOULD INHIBIT FRICTION CONTACT BETWEEN BARRIER SEGMENTS AND DECK.

ALL MARKINGS SHALL BE PERMANENTLY IMPRINTED ON THE BARRIER USING A MINIMUM OF 50 mm HIGH LETTERING.

HANDLING DEVICES MAY BE USED IN LIEU OF THE LIFTING SLOTS FOR MOVING THE BARRIER. THEY MAY BE OF ANY DESIGN SUFFICIENT TO HANDLE THE WEIGHT OF THE SECTION BEING LIFTED. NO REMAINING HANDLING DEVICES SHALL PROTRUDE ABOVE THE BARRIER SURFACE.

THE PROJECT PLANS SHALL INDICATE THE NUMBER OF ANCHORS PER SEGMENT, AS WELL AS THE BARRIER LOCATION ON THE BRIDGE DECK, AND ANY SPECIAL ANCHORAGE REQUIREMENTS.

"J-J HOOKS" CONNECTIONS MAY BE UTILIZED IN LIEU OF THE END CONNECTIONS DETAILED. EACH BRIDGE BARRIER SECTION USING "J-J HOOKS" SHALL REQUIRE ANCHORING AS PER DETAIL C. THE NUMBER OF ANCHORS SHALL BE THE GREATER OF TWO ANCHORS, IF THE PROJECT PLANS DO NOT SPECIFY A NUMBER OF ANCHORS PER BARRIER SECTION, OR DOUBLE THE NUMBER OF ANCHORS SPECIFIED BY THE PLANS. "J-J HOOKS" IS A TRADEMARK OF EASI-SET INDUSTRIES, P.O. BOX 300, MIDLAND, VA 22728.