

BRIDGE RAILING GENERAL NOTES

APPLICATION: THIS DRAWING APPLIES TO BRIDGES WITH RAILINGS DESIGNED IN ACCORDANCE WITH RETIRED STANDARD BRIDGE DRAWINGS AR-1-57 AND BR-1-65 AND HAVING SAFETY CURB WIDTHS OF 1'-0" OR 2'-0". EXCEPT AS NOTED ON SHEET 2 OF 3, THIS RAILING DESIGN IS ACCEPTABLE FOR USE ON THE NATIONAL HIGHWAY SYSTEM (NHS).

FOR BRIDGE TERMINAL ASSEMBLY DETAILS, REFER TO STANDARD CONSTRUCTION DRAWING GR-3.3.

REMOVALS: REMOVE EXISTING ALUMINUM RAILING, POSTS AND PORTIONS OF PARAPETS ACCORDING TO ITEM 202. REMOVE CONCRETE USING FULL DEPTH SAW CUTS WHERE POSSIBLE. CHIPPING HAMMERS SHALL BE CLOSED HANDLE ("D" HANDLE) NO LARGER THAN THE 20 POUND CLASS. EXPOSED PORTIONS OF EXISTING POST ANCHORS THAT DO NOT INTERFERE WITH THE RETROFIT RAILING SHALL BE REMOVED FLUSH WITH EXISTING CONCRETE PARAPET. EMBEDDED PORTIONS OF EXISTING ANCHORS MAY REMAIN IN PLACE.

CAREFULLY REMOVE CONCRETE SUPPORTING EXISTING EXPANSION JOINT ARMOR AND CURB PLATES. IF THE ENGINEER DETERMINES DAMAGE HAS OCCURED DURING THE CONCRETE REMOVAL OPERATION, SUBMIT A CORRECTIVE WORK PLAN IN ACCORDANCE WITH C&MS 501.05.D.

CONCRETE: FURNISH CLASS C CONCRETE ACCORDING TO C&MS 511.

THRIE BEAM BRIDGE RAILING: FURNISH MATERIAL ACCORDING TO THE PROVISIONS OF 710.06 EXCEPT THE MATERIAL SHALL BE AASHTO M180, TYPE II, CLASS B (10 GAGE).

STRUCTURAL STEEL: FABRICATE STRUCTURAL STEEL ACCORDING TO C&MS 513.

ANGLES SHALL CONFORM TO C&MS 711.01.

TUBING SHALL CONFORM TO THE PROVISIONS OF 707.10.

FASTENERS:

BUTTON HEAD BOLTS SHALL BE 5/8" DIA. ASTM A307 WITH A PLATE WASHER UNDER THE HEAD AND A STANDARD WASHER UNDER THE NUT.

3/4" DIA. HIGH STRENGTH THREADED ANCHORS, NUTS AND WASHERS SHALL CONFORM TO ASTM A449. GALVANIZE ACCORDING TO ASTM A153. INSTALL ANCHORS ACCORDING TO CC&MS510 USING NON-SHRINK GROUT, 705.20. ANCHORS SHALL BE EMBEDDED A MINIMUM OF 7" INTO THE EXISTING CONCRETE PARAPET.

3/4" DIA. HIGH STRENGTH THREADED BOLTS, NUTS AND WASHERS SHALL CONFORM TO 711.09 (ASTM A325).

1" DIA. HIGH STRENGTH THREADED ANCHOR BOLTS, NUTS AND WASHERS SHALL CONFORM TO ASTM A449. GALVANIZE ACCORDING TO ASTM A153.

GALVANIZE RAILING SUPPORT BRACKET ASSEMBLIES, HARDWARE AND ACCESSORIES IN ACCORDANCE WITH 711.02.

REINFORCING STEEL SHALL BE EPOXY COATED, C&MS 709.00.

DOWEL HOLES FOR REINFORCING STEEL SHALL BE IN ACCORDANCE WITH C&MS 510 USING NON-SHRINK GROUT, 705.20.

WOOD BLOCKS: FURNISH MATERIAL CONFORMING TO C&MS 710.14.

THRIE BEAM EXPANSION: TIGHTEN ALL BOLTS IN THE OFF STRUCTURE END OF THE APPROACH PANEL THRIE BEAM RAIL SECTION THAT SPANS THE ABUTMENT AS SPECIFIED FOR EXPANSION JOINTS IN 606.04.

SEALING CONCRETE SURFACES: SEAL THE CONCRETE REMOVAL SURFACES WITH A NON-EPOXY SEALER, IN ACCORDANCE WITH C&MS 512.

METHOD OF MEASUREMENT: THE DEPARTMENT WILL MEASURE RETROFIT RAILING BY THE NUMBER OF FEET. THE MEASURED LENGTH WILL BE BETWEEN THE CENTER OF THE FIRST POST BLOCKOUT ON THE BRIDGE TO THE CENTER OF THE LAST POST BLOCKOUT ON THE BRIDGE.

BASIS OF PAYMENT: THE DEPARTMENT WILL INCLUDE ALL COSTS ASSOCIATED WITH REMOVALS; SEALING OF CONCRETE; DOWEL HOLES; REINFORCING STEEL; CONCRETE; PREFORMED PADS; AND RAILING HARDWARE WITH THE ACCEPTED QUANTITIES AT THE CONTRACT PRICE AS FOLLOWS:

ITEM 517, RAILING (THRIE BEAM RETROFIT).

ALTERNATE CURB DETAILS

THESE DETAILS MAY BE USED IN LIEU OF THOSE SHOWN ON SHEET 2 OF 3 FOR AR-1-57 OR BR-1-65 RAILINGS ON ABUTMENTS WITH STRAIGHT WINGWALLS WHERE ANCHORAGE OF STEEL EXPANSION JOINT ARMOR IN THE CURBING IS NOT REQUIRED. THIS DETAIL IS ACCEPTABLE FOR USE ON THE NHS.

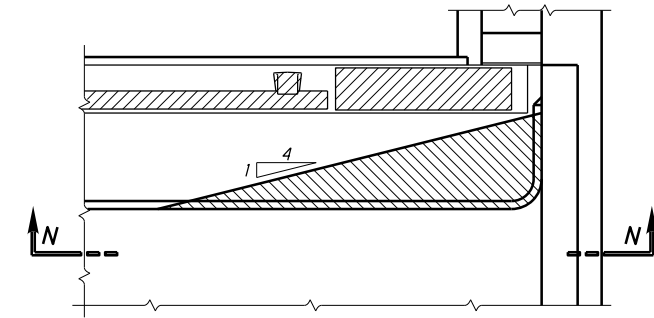

PART PLAN

(BR-1-65 RAILING ON ABUTMENT WITHOUT EXPANSION JOINT ARMOR SHOWN, AR-1-57 RAILING SIMILAR)

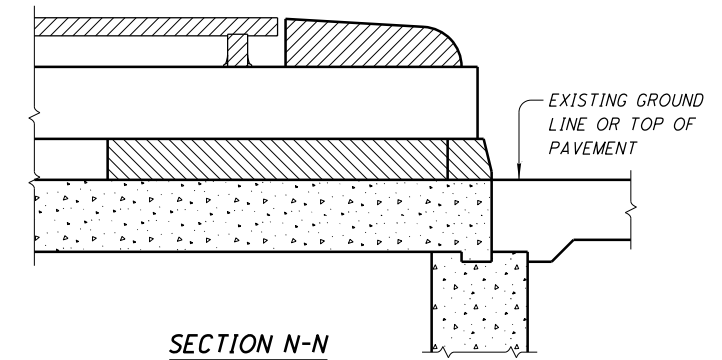

SECTION N-N

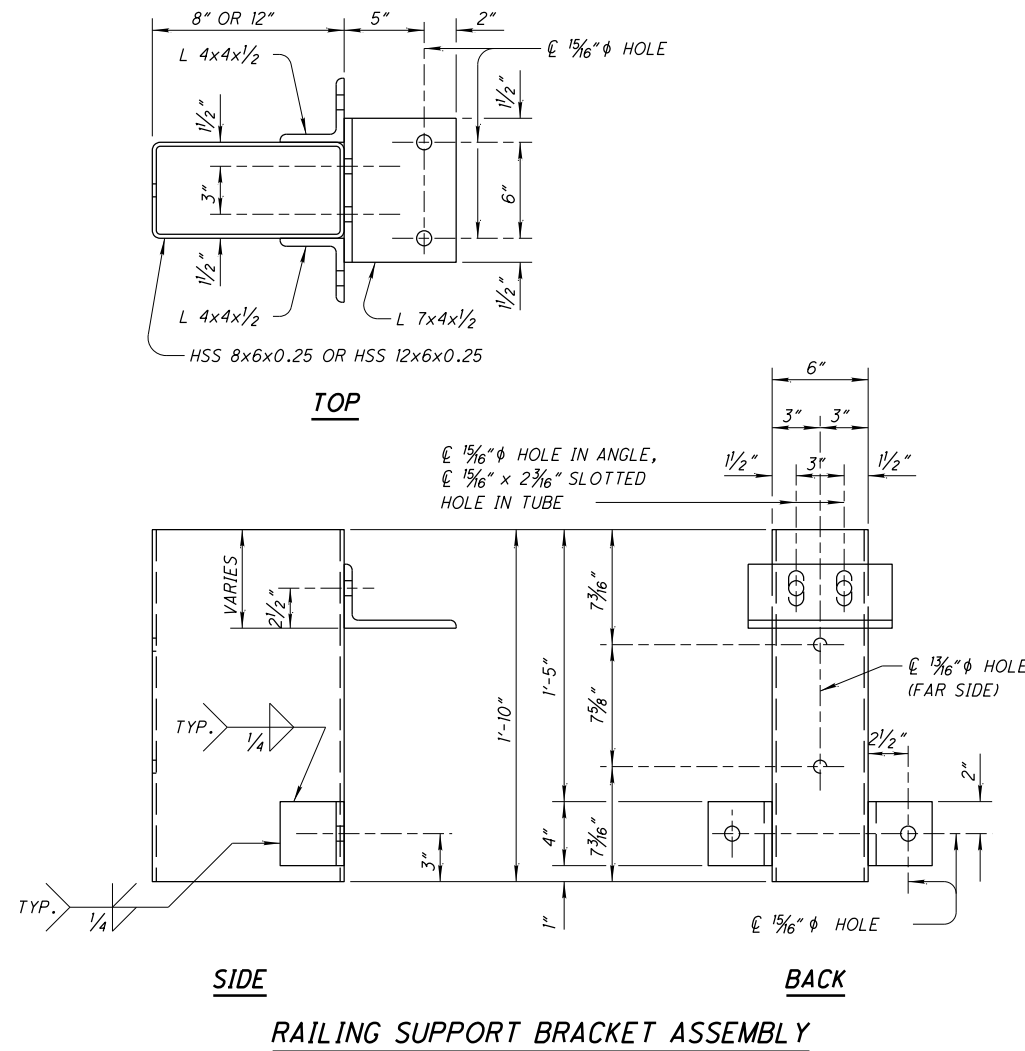

RAILING SUPPORT BRACKET ASSEMBLY

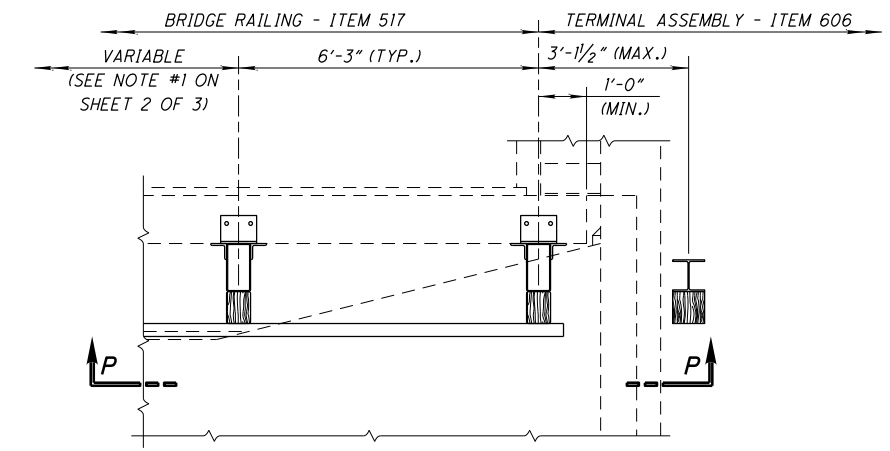

PART PLAN

(BR-1-65 RAILING ON ABUTMENT WITHOUT EXPANSION JOINT ARMOR SHOWN, AR-1-57 RAILING SIMILAR)

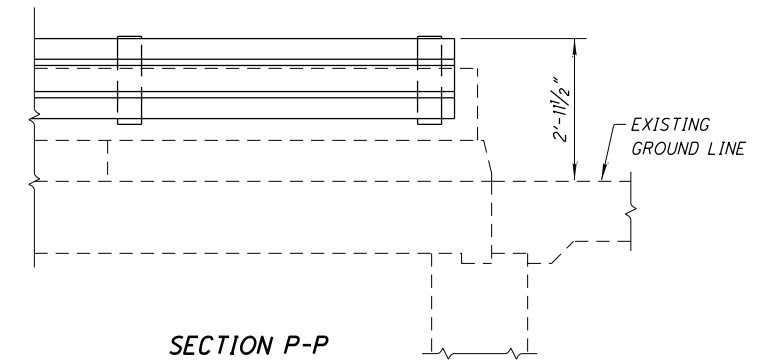

SECTION P-P