

TRANSVERSE JOINTS

CONTRACTION JOINT

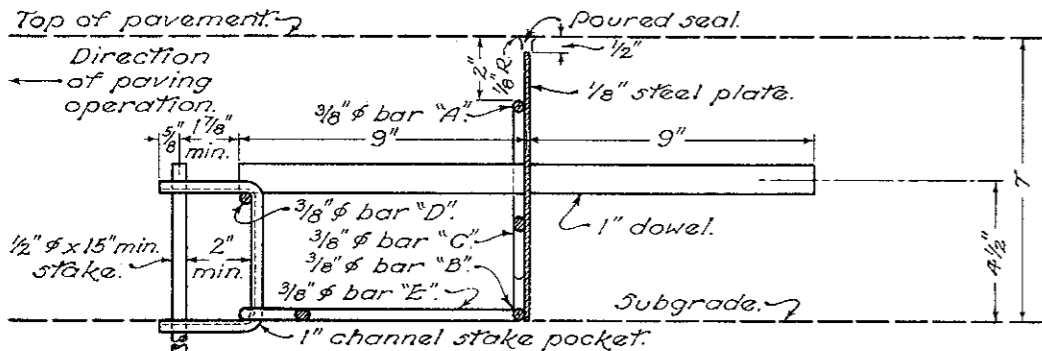

SECTION THROUGH JOINT

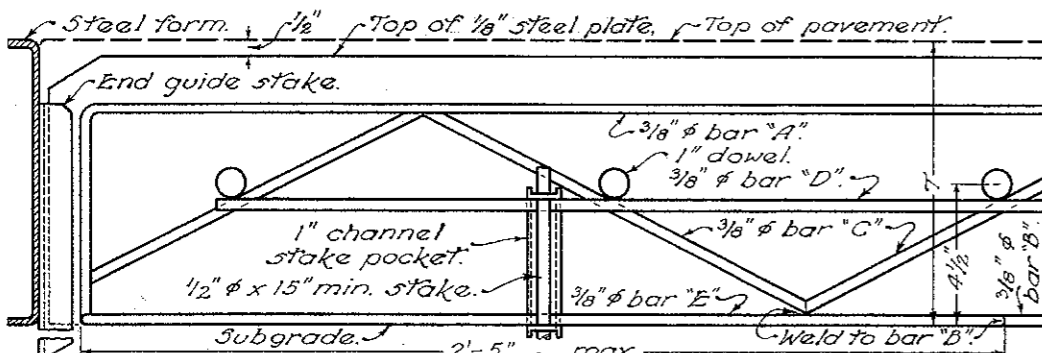

SIDE ELEVATION

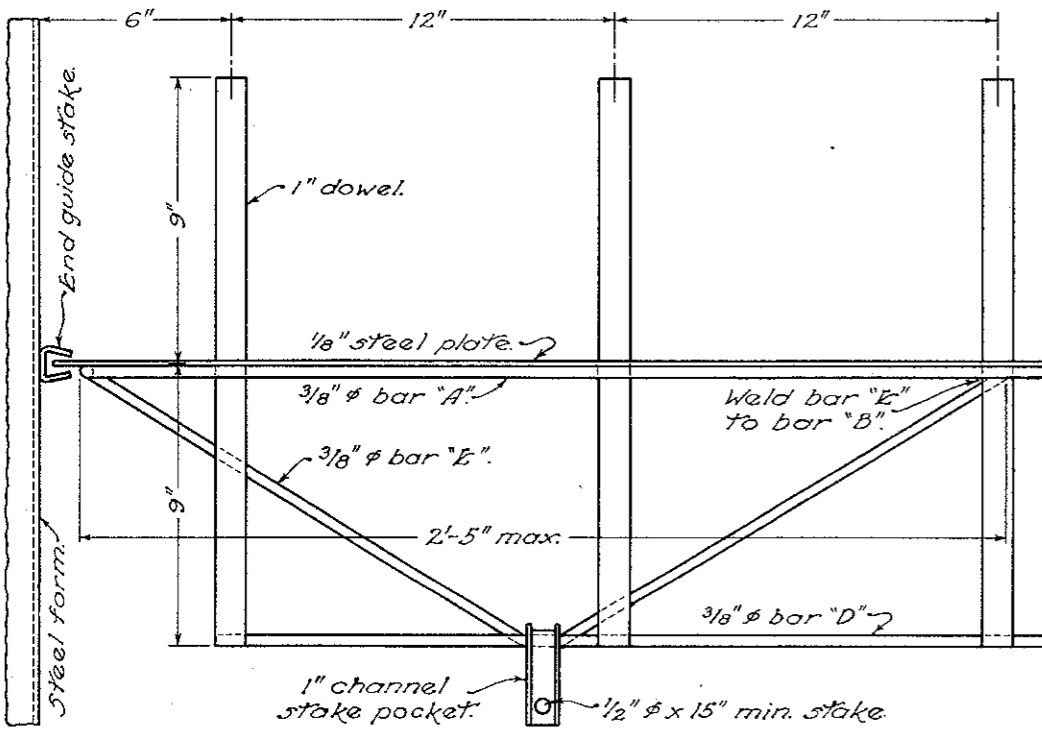

PLAN

EXPANSION JOINT

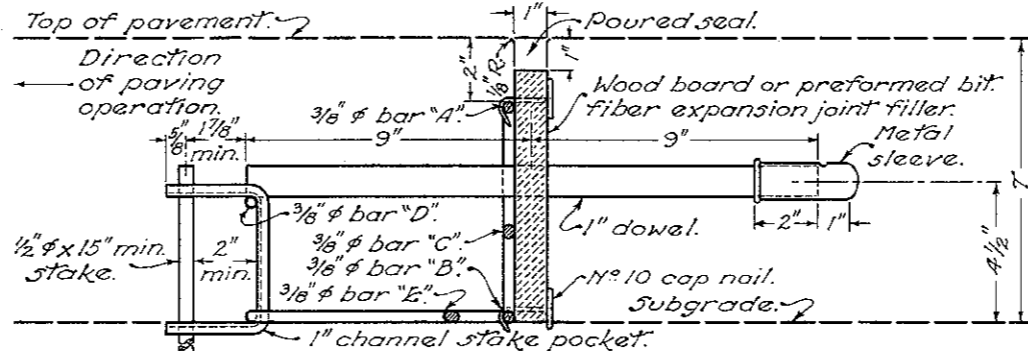

SECTION THROUGH JOINT

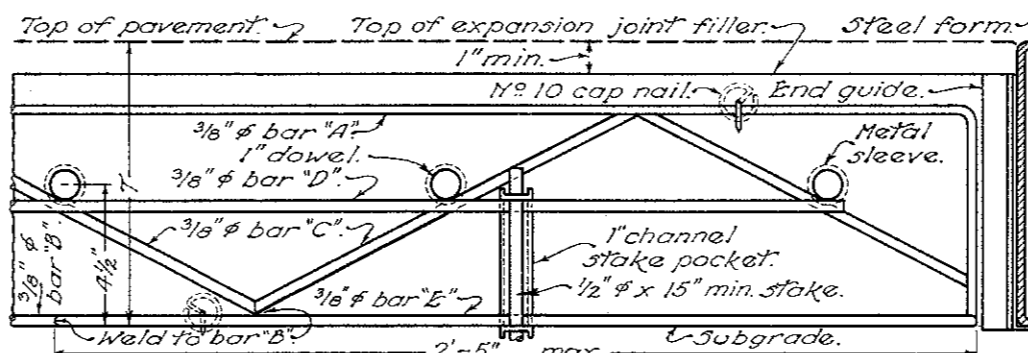

SIDE ELEVATION

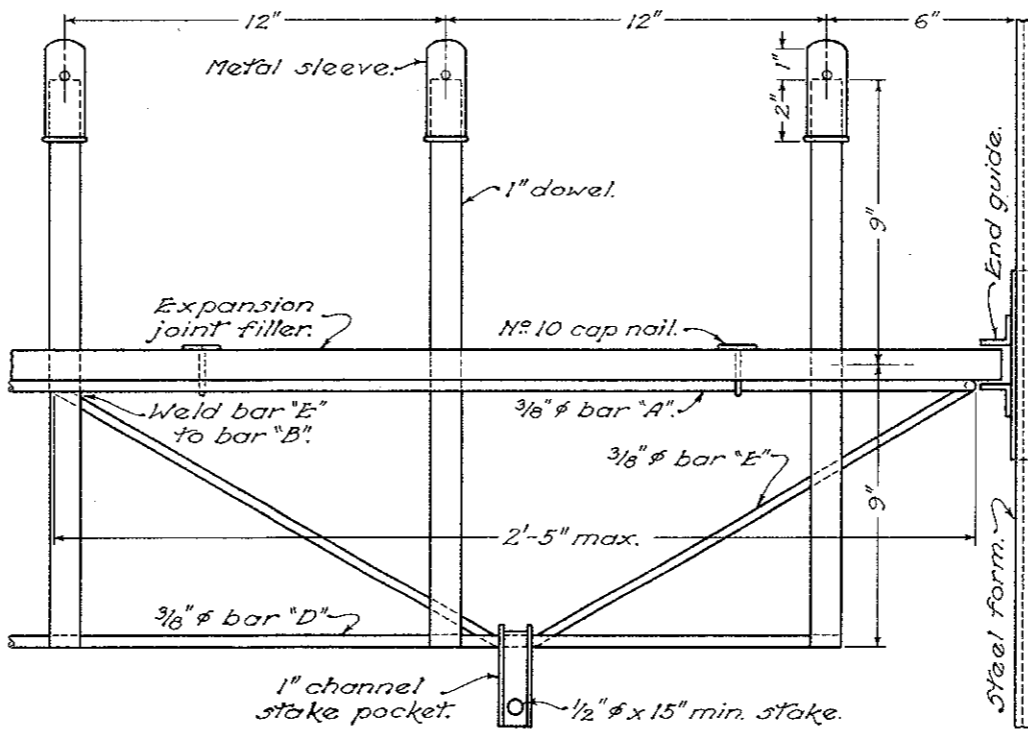

PLAN

NOTES

GENERAL:—The welded dowel assembly shall be shop fabricated in such a manner as to form a rigid truss-like framework with sufficient strength to hold the dowels and joint material in proper position during concrete placing and finishing operations.

The base of the rod of the dowel assembly and the bottom of the expansion material shall be shaped to the section of the pavement.

DOWELS:—Load transfer device shall consist of 1" round, smooth, straight steel bars. The free ends of the dowels shall be thoroughly coated with either bituminous material 3C-2 or 3 or an oil such as SAE 140 or equal just prior to placing the assembly in position.

ASSEMBLY:—The dowel bars shall be welded to the 3/8" "C" and "D" bars at the center and one end of the dowel in such a manner that the dowels will be parallel to the surface and centerline of the pavement.

The joint assembly shall be continuous between longitudinal joints and shall be held in place by end guides as shown and by brace rods securely staked to the subgrade. Stake pockets shall be uniformly spaced at intervals not to exceed 5'-0".

A satisfactory device shall be used to assure that the end guide stakes are driven perpendicular to the grade of the form line.

EXPANSION JOINTS:—Wood board, Sec. M-10.03, and preformed bituminous fiber, Sec. M-10.02 shall be considered as alternatives. The type used on any project is optional with the contractor.

Expansion joints shall be used only at intersections as designated on the plan and at structures against which the pavement abuts. Two expansion joints shall be placed on each side of each structure of approximately 15' and 65' intervals from the end of the approach slab or in the case of a skewed approach slab, approximately 15' and 65' from the point of the approach slab farthest from the structure.

The expansion material shall be held accurately and rigidly in place by means of the cap nails provided for this purpose. The top of the expansion material shall be protected during paving operations by a 12 gage metal cap or shield designed to fit down over the expansion material a minimum distance of 1/2" the metal cap shall be removed immediately after the final pass of the finishing machine. When two adjacent lanes are poured simultaneously, the metal cap shall be continuous across the longitudinal joint.

The free ends of the dowels shall be equipped after greasing with a metal sleeve approximately 3" long, designed with a crimped end and overlapping seam which fits closely around the dowel. Provision shall be made by a depression or inferior projection in the sleeve to act as a stop for the dowel 1" from the crimped end to allow for longitudinal dowel movement with pavement expansion.

Dowel holes 1/8" in diameter shall be punched or drilled into the expansion material to insure tight fitting dowels.

Joints in monolithic curbs shall be constructed of the same type of filler material as used in the expansion joints.

CONTRACTION AND CONSTRUCTION JOINTS:—A steel plate 1/8" thick shall be used in contraction and construction joints. The plate shall have 1/8" diameter holes punched to accommodate the 1" dowels. Additional anchor pins shall be used opposite the brace rods to hold the plate in place for contraction joints or the plate may be welded to the dowels.

The steel plate shall be held rigidly in place for construction joints in a manner that will provide a full depth joint perpendicular to the surface. A plate of sufficient stiffness and slotted to fit over the dowel bars shall be used adjacent to the metal plate and sufficiently well staked to hold the metal plate in correct position. This plate shall be removed prior to resumption of concreting operations.

The position of the dowel assembly shall be reversed for construction joints so that the free end of the dowel will point toward the direction of paving operations.

Contraction joints shall be spaced at intervals of 99'-4" in reinforced Portland cement concrete pavement. Contraction joints will not be permitted in concrete base courses.

JOINT FINISHING:—Care shall be exercised in edging joints that the proper radius is maintained. Any impression left in the surface of the pavement by the flat part of the edging tool shall be eliminated, but in no case will the addition of gravel be permitted for this purpose. Final belt finish shall be applied to the pavement surface adjacent to joints as is required for the balance of the pavement area and particular attention shall be given to straight edging the pavement across joints to insure no difference in the elevation of the pavement surface on opposite sides of the joint.

POURED SEAL:—The material for poured seal shall meet the requirements of Supplemental Specification M-110.23.

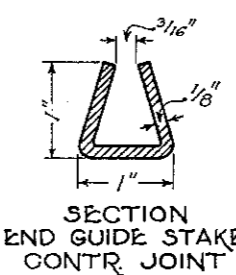

SECTION END GUIDE STAKE CONTR. JOINT

BUREAU OF LOCATION AND DESIGN OHIO DEPARTMENT OF HIGHWAYS	
PAVEMENT JOINTS	
STANDARD CONSTRUCTION DRAWING	T. J. No. 3
APPROVED <i>[Signature]</i>	CHIEF ENGINEER

DATE 2-7-50

The junction of all bars shall be welded. Dowels shall be welded to bars "C" and "D". Channels shall be welded to bars "D" and "E".

TRANSVERSE JOINTS

CONTRACTION JOINT

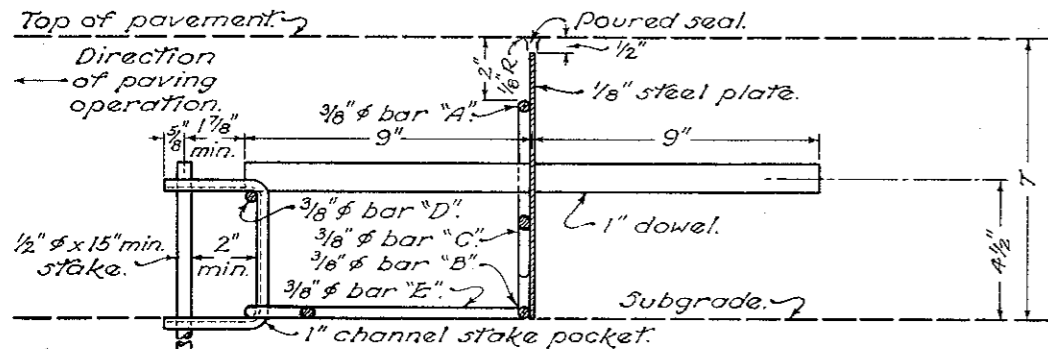

SECTION THROUGH JOINT

EXPANSION JOINT

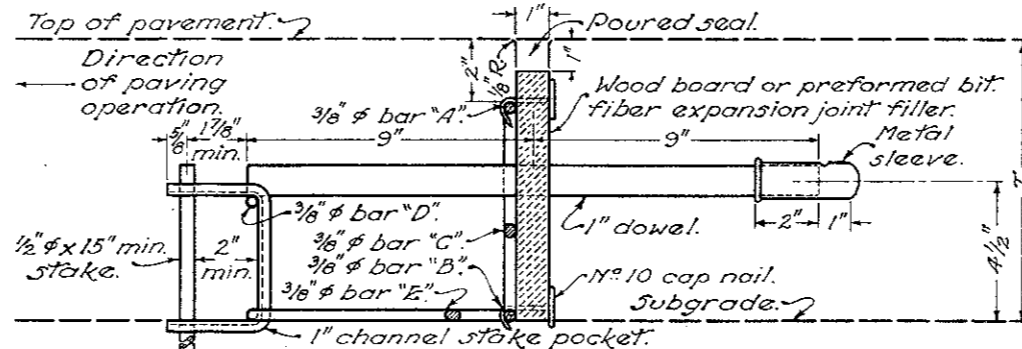

SECTION THROUGH JOINT

NOTES

GENERAL:—The welded dowel assembly shall be shop fabricated in such a manner as to form a rigid T-shaped framework with sufficient strength to hold the dowels and joint material in proper position during concrete placing and finishing operations.

The base of the rod of the dowel assembly and the bottom of the expansion material shall be shaped to the section of the pavement.

DOWELS:—Load transfer device shall consist of 1" round, smooth, straight steel bars. The free ends of the dowels shall be thoroughly coated with either bituminous material 5C-2 or 3 or an oil such as JAE 140 or equal just prior to placing the assembly in position.

ASSEMBLY:—The dowel bars shall be welded to the 3/8" C and D bars at the center and one end of the dowel in such a manner that the dowels will be parallel to the surface and centerline of the pavement.

The joint assembly shall be continuous between longitudinal joints and shall be held in place by end guides as shown and by brace rods securely staked to the subgrade. Stake pockets shall be uniformly spaced at intervals not to exceed 3'-0".

A satisfactory device shall be used to assure that the end guide stakes are driven perpendicular to the grade of the form line.

EXPANSION JOINTS:—Wood board, Sec. M-10.03, and preformed bituminous fiber, Sec. M-10.02, shall be considered as alternatives. The type used on any project is optional with the contractor.

Expansion joints shall be used only at intersections as designated on the plan and at structures against which the pavement abuts. Two expansion joints shall be placed on each side of each structure at approximately 15' and 65' intervals from the end of the approach slab or in the case of a skewed approach slab, approximately 15' and 65' from the point of the approach slab farthest from the structure.

The expansion material shall be held accurately and rigidly in place by means of the cap nails provided for this purpose. The top of the expansion material shall be protected during paving operations by a 12 gage metal cap or shield designed to fit down over the expansion material a minimum distance of 1/2". The metal cap shall be removed immediately after the final pass of the finishing machine. When two adjacent lanes are poured simultaneously, the metal cap shall be continuous across the longitudinal joint.

The free ends of the dowels shall be equipped after greasing with a metal sleeve approximately 3" long, designed with a crimped end and overlapping seam which fits closely around the dowel. Provision shall be made by a depression or inferior projection in the sleeve to act as a stop for the dowel 1" from the crimped end to allow for longitudinal dowel movement with pavement expansion.

Dowel holes 1/8" in diameter shall be punched or drilled into the expansion material to insure tight fitting dowels.

Joints in monolithic curbs shall be constructed of the same type of filler material as used in the expansion joints.

CONTRACTION AND CONSTRUCTION JOINTS:—A steel plate 1/8" thick shall be used in contraction and construction joints. The plate shall have 1/8" diameter holes punched to accommodate the 1" dowels. Additional anchor pins shall be used opposite the brace rods to hold the plate in place for contraction joints or the plate may be welded to the dowels.

The steel plate shall be held rigidly in place for construction joints in a manner that will provide a full depth joint perpendicular to the surface. A plate of sufficient stiffness and slotted to fit over the dowel bars shall be used adjacent to the metal plate and sufficiently well staked to hold the metal plate in correct position. This plate shall be removed prior to resumption of concreting operations.

The position of the dowel assembly shall be reversed for construction joints so that the free end of the dowel will point toward the direction of paving operations.

Contraction joints shall be spaced at intervals of 100' in reinforced Portland cement concrete pavement. Contraction joints will not be permitted in concrete base courses.

JOINT FINISHING:—Care shall be exercised in edging joints that the proper radius is maintained. Any impression left in the surface of the pavement by the flat part of the edging tool shall be eliminated, but in no case will the addition of gravel be permitted for this purpose. Final belt finish shall be applied to the pavement surface adjacent to joints as is required for the balance of the pavement area and particular attention shall be given to straight edging the pavement across joints to insure no difference in the elevation of the pavement surface on opposite sides of the joint.

POURED SEAL:—The material for poured seal shall meet the requirements of Supplemental Specification M-110.23.

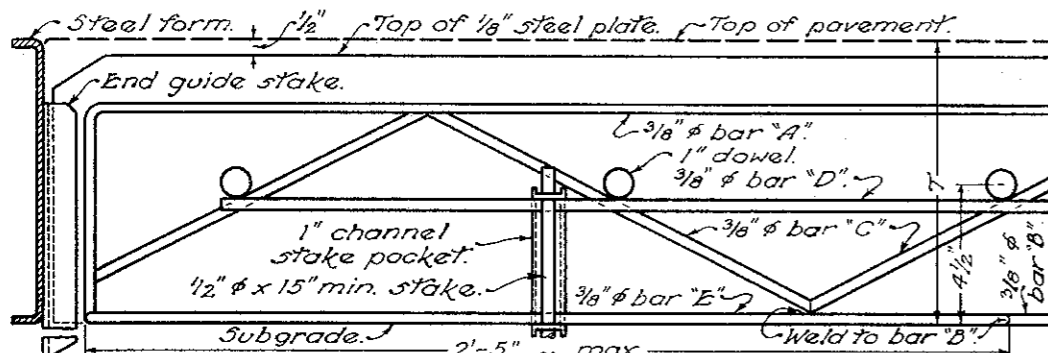

SIDE ELEVATION

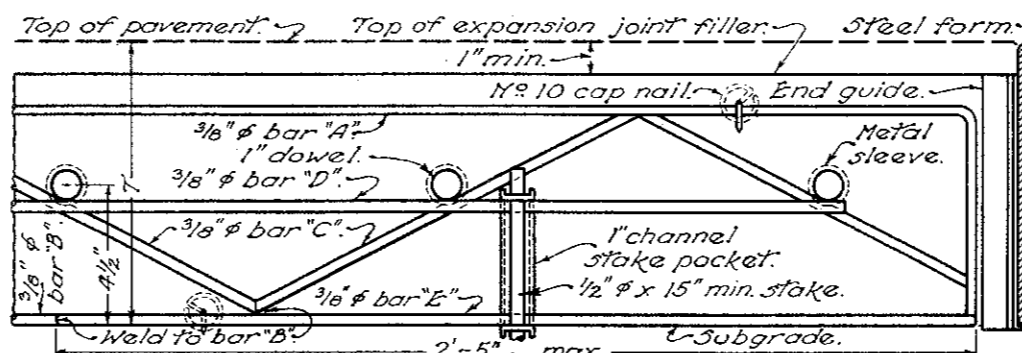

SIDE ELEVATION

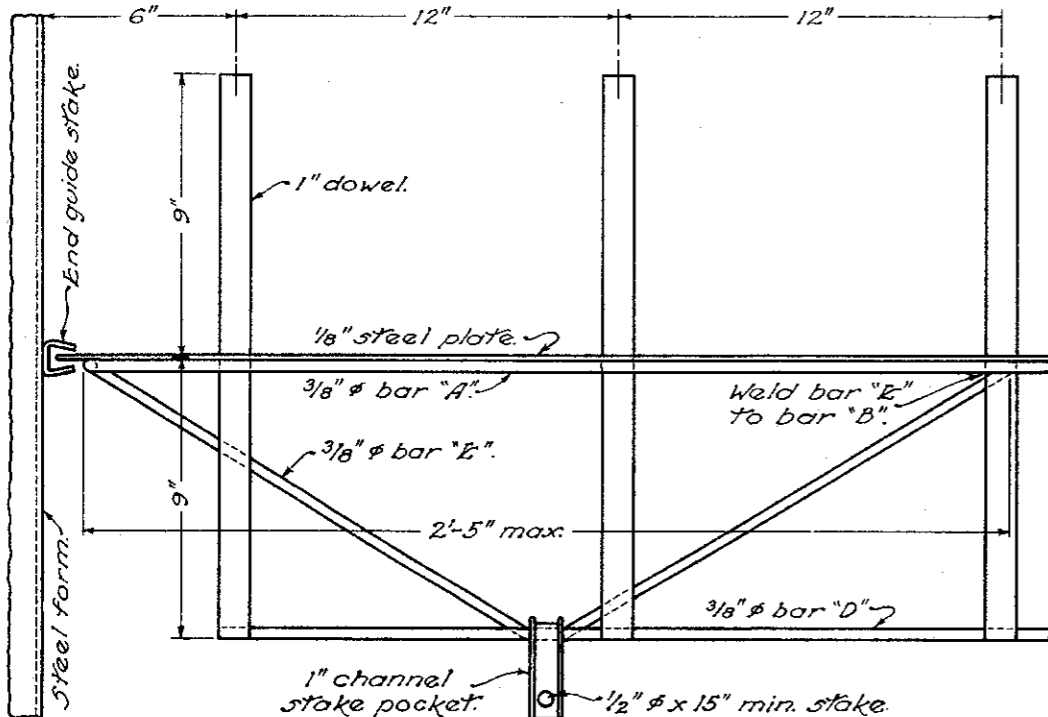

PLAN

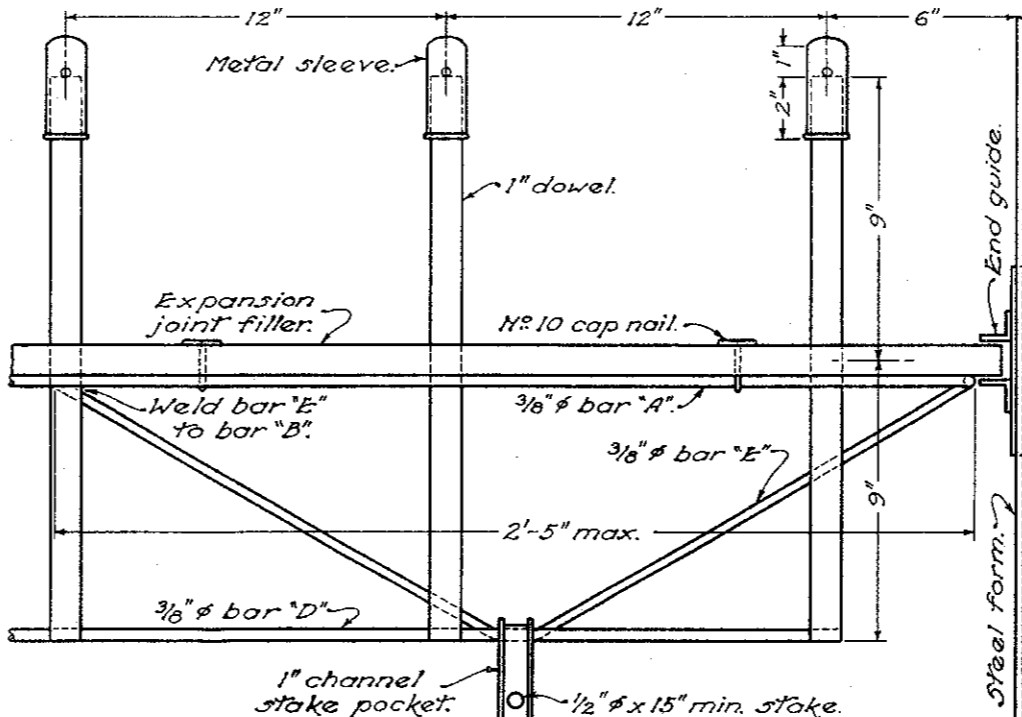

PLAN

The junction of all bars shall be welded. Dowels shall be welded to bars "C" and "D". Channels shall be welded to bars "D" and "E".

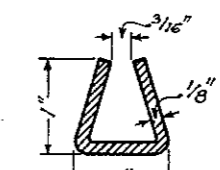

SECTION END GUIDE STAKE CONTR. JOINT

BUREAU OF LOCATION AND DESIGN
OHIO DEPARTMENT OF HIGHWAYS

DATE
2-7-50
7-1-50

PAVEMENT JOINTS

STANDARD CONSTRUCTION DRAWING
APPROVED *[Signature]* CHIEF ENGINEER
T. J. No. 3

TRANSVERSE JOINTS

EXPANSION JOINT

NOTES

CONTRACTION JOINT

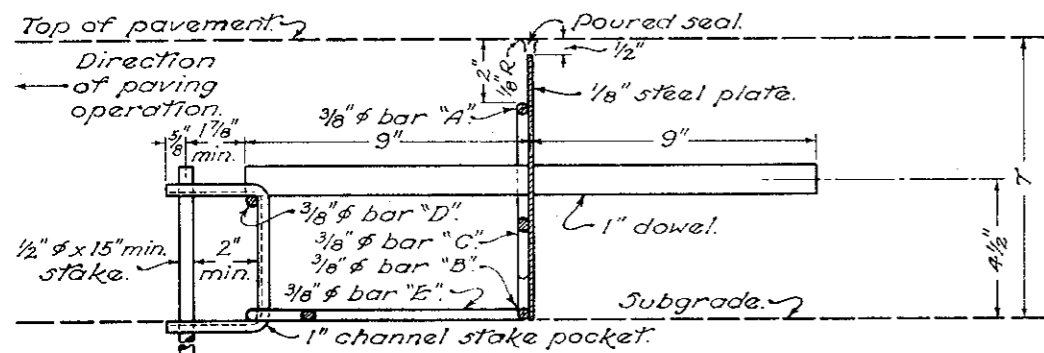

SECTION THROUGH JOINT

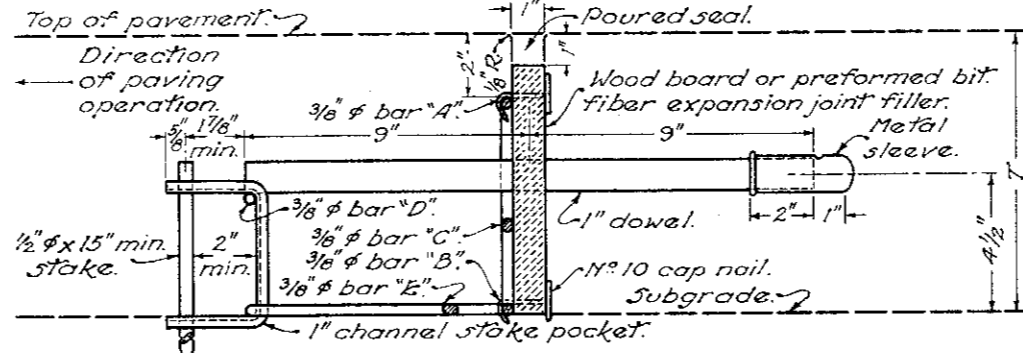

SECTION THROUGH JOINT

GENERAL:—The welded dowel assembly shall be shop fabricated in such a manner as to form a rigid truss-like framework with sufficient strength to hold the dowels and joint material in proper position during concrete placing and finishing operations.

The base of the rod of the dowel assembly and the bottom of the expansion material shall be shaped to the section of the pavement.
DOWELS:—Load transfer device shall consist of 1" round, smooth, straight steel bars. The free ends of the dowels shall be thoroughly coated with either bituminous material SC-2 or 3 or an oil such as SAE 140 or equal just prior to placing the assembly in position.

ASSEMBLY:—The dowel bars shall be welded to the 3/8" "C" and "D" bars at the center and one end of the dowel in such a manner that the dowels will be parallel to the surface and centerline of the pavement.

The joint assembly shall be continuous between longitudinal joints and shall be held in place by end guides as shown and by brace rods securely staked to the subgrade. Stake pockets shall be uniformly spaced at intervals not to exceed 5'-0".

A satisfactory device shall be used to assure that the end guide stakes are driven perpendicular to the grade of the form line.

Dowel cages are dimensioned for pavement lanes of even foot widths. Where other widths are specified, standard cages may be used with dowel spacings adjusted as follows:

The 6 inch dowel spacing shall be maintained at the longitudinal joint. The spacing at the outer edge of the lane may be increased up to 12 inches, where an odd width of lane occurs and the dowel spacing at the outside edge of the lane, when using a standard cage, would exceed 12 inches, a dowel shall be placed 6 inches from the outer edge of the lane and held rigidly in proper position by a method satisfactory to the Engineer, or a dowel cage of greater length than required may be used by cutting the assembly and splicing to attain the required length. In all cases the steel plate or metal sleeve shall be full length for the width of the lane to engage the end guide.

The joint assembly shown hereon is for use with uniform depth pavement. The joint assembly for variable depth pavement shall be in accordance with the design shown on the plan.

EXPANSION JOINTS:—Wood board Sec. M-10.03 and preformed bituminous fiber Sec. M-10.02 shall be considered as alternatives. The type used on any project is optional with the contractor.

Expansion joints shall be used only at intersections as designated on the plan and at structures against which the pavement abuts. Two expansion joints shall be placed on each side of each structure at approximately 15' and 65' intervals from the end or the approach slab or in the case of a skewed approach slab, approximately 15' and 65' from the point of the approach slab from the structure.

The expansion material shall be held accurately and rigidly in place by means of the cap nails provided for this purpose. The top of the expansion material shall be protected during paving operations by a 12 gage metal cap or shield designed to fit down over the expansion material a minimum distance of 1/2". The metal cap shall be removed immediately after the final pass of the finishing machine. When two adjacent lanes are poured simultaneously, the metal cap shall be continuous across the longitudinal joint.

The free ends of the dowels shall be equipped after greasing with a metal sleeve approximately 3" long, designed with a crimped end and overlapping seam which fits closely around the dowel. Provision shall be made by a depression or interior projection in the sleeve to act as a stop for the dowel 1" from the crimped end to allow for longitudinal dowel movement with pavement expansion.

Dowel holes 1/8" in diameter shall be punched or drilled into the expansion material to insure tight fitting dowels.

Joints in monolithic curbs shall be constructed of the same type of filler material as used in the expansion joints.

CONTRACTION AND CONSTRUCTION JOINTS:—A steel plate 1/8" thick shall be used in contraction and construction joints. The plate shall have 1/8" diameter holes punched to accommodate the dowels. Additional anchor pins shall be used opposite the brace rods to hold the plate in place for contraction joints or the plate may be welded to the dowels. The steel plate shall be held rigidly in place for construction joints in a manner that will provide a full depth joint perpendicular to the surface. A plate of sufficient stiffness and slotted to fit over the dowel bars shall be used adjacent to the metal plate and sufficiently well staked to hold the metal plate in correct position. This plate shall be removed prior to resumption of concreting operations.

The position of the dowel assembly shall be reversed for construction joints so that the free end of the dowel will point toward the direction of paving operations.

Contraction joints shall be spaced at intervals of 100' in reinforced Portland cement concrete pavement. Contraction joints will not be permitted in concrete base courses.

JOINT FINISHING:—Care shall be exercised in edging joints that the proper radius is maintained. Any impression left in the surface of the pavement by the flat part of the edging tool shall be eliminated, but in no case will the addition of gravel be permitted for this purpose. Final belt finish shall be applied to the pavement surface adjacent to joints as is required for the balance of the pavement area and particular attention shall be given to straight edging the pavement across joints to insure no difference in the elevation of the pavement surface on opposite sides of the joint.

POURED SEAL:—The material for poured seal shall meet the requirements of Section M-10.23.

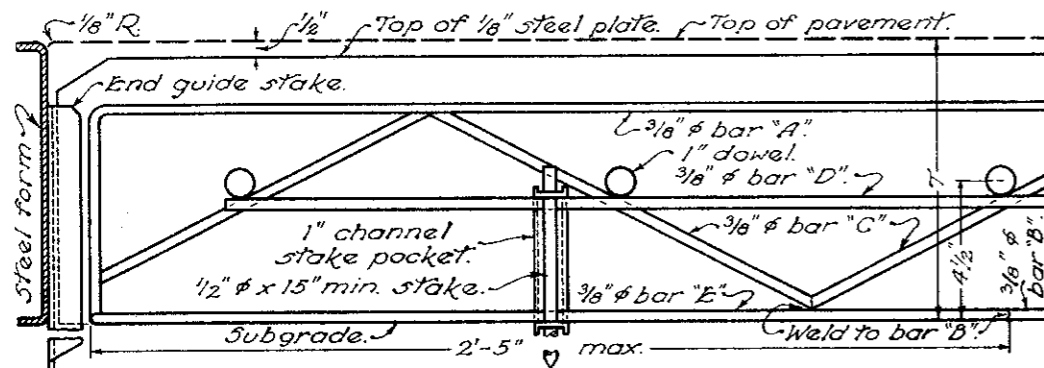

SIDE ELEVATION

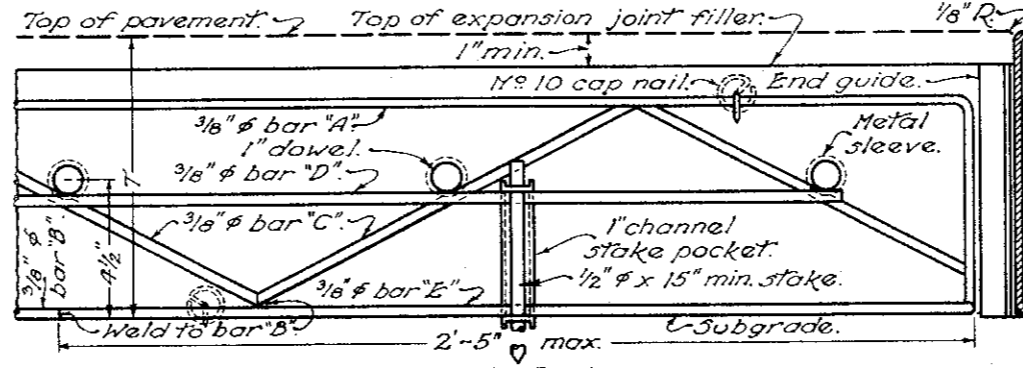

SIDE ELEVATION

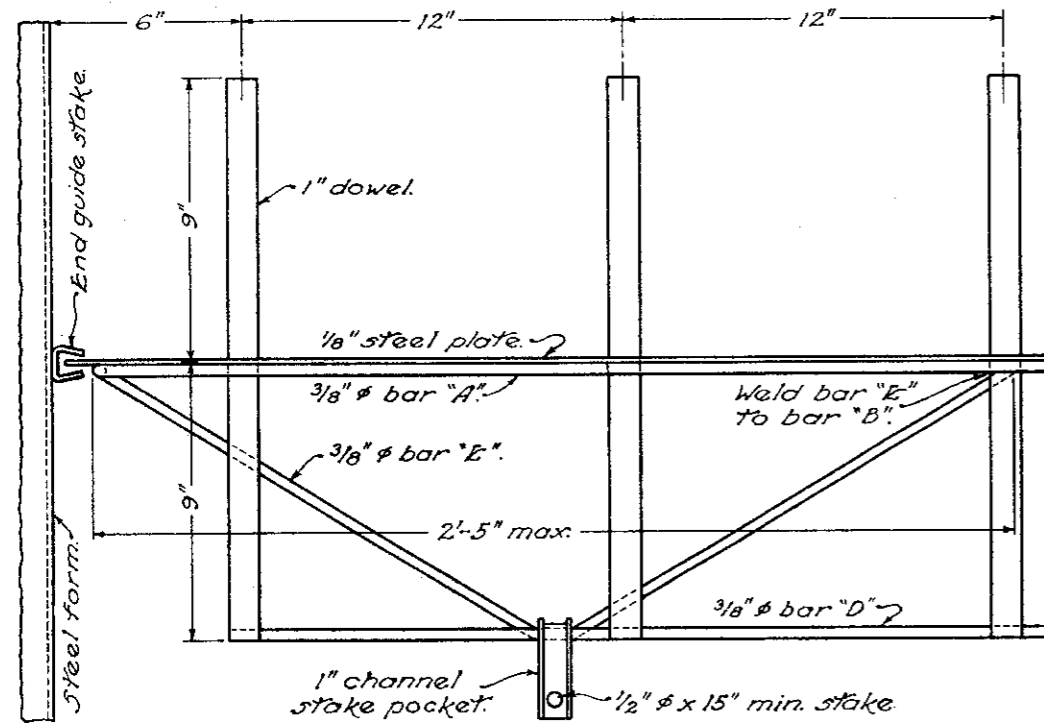

PLAN

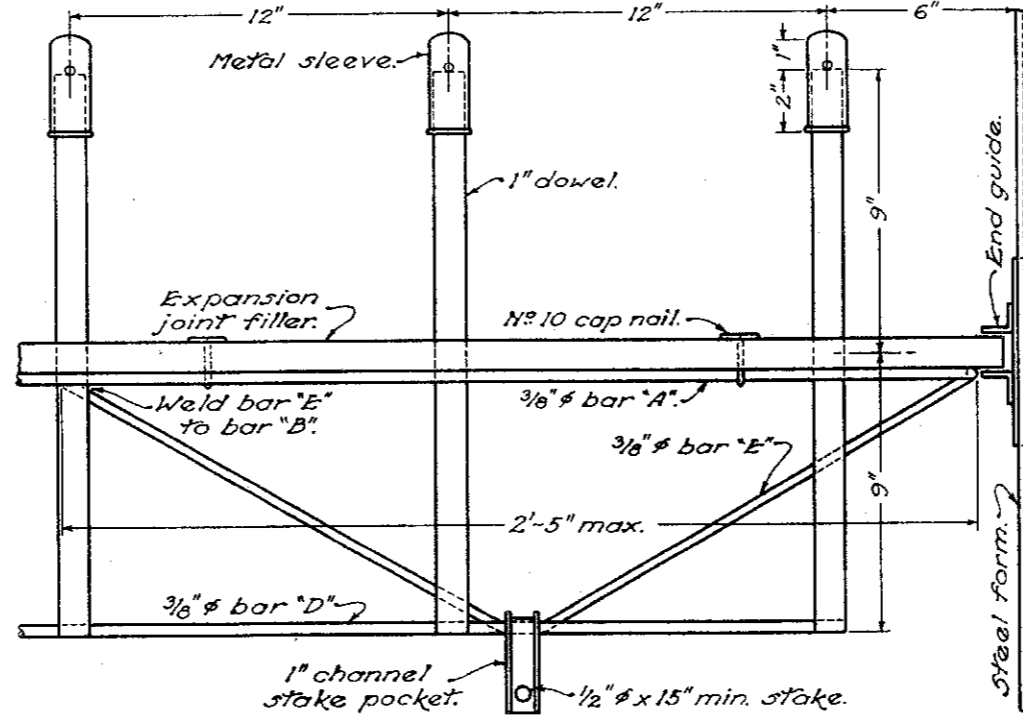

PLAN

The junction of all bars shall be welded. Dowels shall be welded to bars "C" and "D". Channels shall be welded to bars "D" and "E".

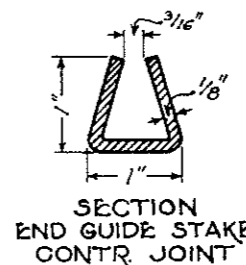

SECTION END GUIDE STAKE CONTR. JOINT

BUREAU OF LOCATION AND DESIGN
OHIO DEPARTMENT OF HIGHWAYS

PAVEMENT JOINTS

STANDARD CONSTRUCTION DRAWING
APPROVED *[Signature]* CHIEF ENGINEER

T. J. NO. 3

DATE
2-7-50
7-1-50
1-2-51

TRANSVERSE JOINTS

CONTRACTION JOINT

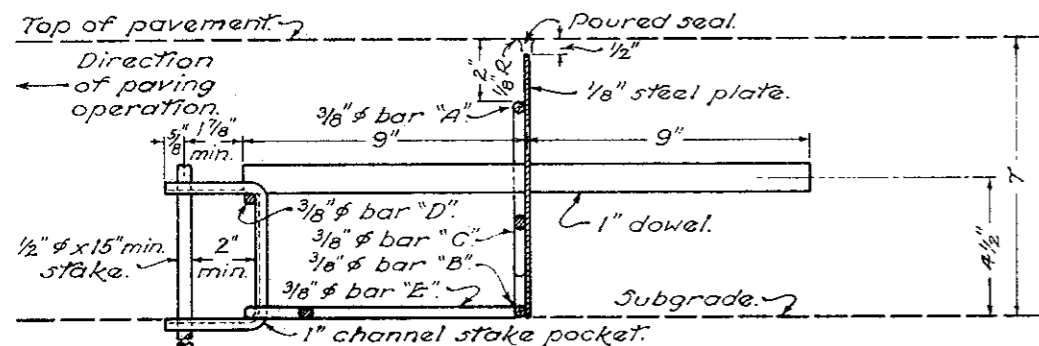

SECTION THROUGH JOINT

EXPANSION JOINT

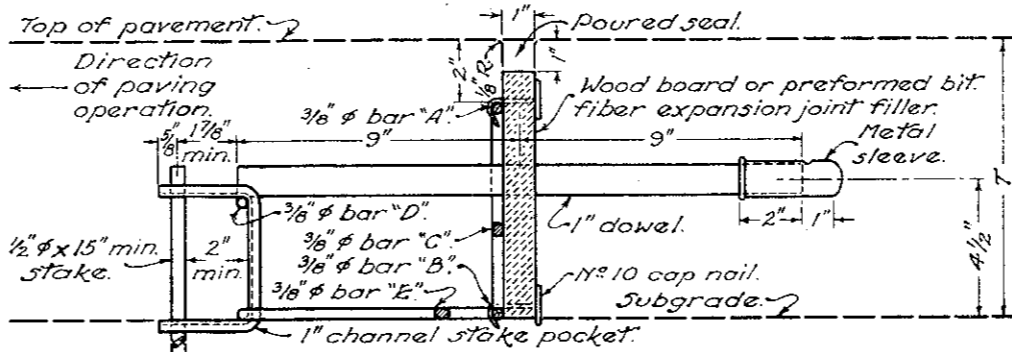

SECTION THROUGH JOINT

NOTES

GENERAL:—The welded dowel assembly shall be shop fabricated in such a manner as to form a rigid truss-like framework with sufficient strength to hold the dowels and joint material in proper position during concrete placing and finishing operations.

The base 1/8" rod of the dowel assembly and the bottom of the expansion material shall be shaped to the section of the pavement.

DOWELS:—Load transfer device shall consist of 1" round, smooth, straight steel bars. The free ends of the dowels shall be thoroughly coated with either bituminous material 5C-2 or 3 or an oil such as SAE 140 or equal just prior to placing the assembly in position.

ASSEMBLY:—The dowel bars shall be welded to the 3/8" C and "D" bars at the center and one end of the dowel in such a manner that the dowels will be parallel to the surface and centerline of the pavement.

The joint assembly shall be continuous between longitudinal joints and shall be held in place by end guides as shown and by brace rods securely staked to the subgrade. Stake pockets shall be uniformly spaced at intervals not to exceed 3'-0".

A satisfactory device shall be used to assure that the end guide stakes are driven perpendicular to the grade of the form line.

Dowel cages are dimensioned for pavement lanes of even foot widths. Where other widths are specified, standard cages may be used with dowel spacings adjusted as follows:—

The 6 inch dowel spacing shall be maintained at the longitudinal joint. The spacing at the outer edge of the lane may be increased up to 12 inches, where an odd width of lane occurs and the dowel spacing at the outside edge of the lane, when using a standard cage, would exceed 12 inches, a dowel shall be placed 6 inches from the outer edge of the lane and held rigidly in proper position by a method satisfactory to the Engineer.

A dowel cage of greater length than required may be used by cutting the assembly and splicing to obtain the required length.

In all cases the steel plate or joint material shall be full length for the width of the lane to engage the end guide.

The joint assembly shown hereon is for use with uniform depth pavement. The joint assembly for variable depth pavement shall be in accordance with the design shown on the plan.

EXPANSION JOINTS:—Wood board, Sec. M-10.03, and preformed bituminous fiber, Sec. M-10.02 shall be considered as alternatives. The type used on any project is optional with the contractor.

Expansion joints shall be used only at intersections as designated on the plan and at structures against which the pavement abuts. Two expansion joints shall be placed on each side of each structure at approximately 15' and 65' intervals from the end of the approach slab or in the case of a skewed approach slab, approximately 15' and 65' from the point of the approach slab farthest from the structure.

The expansion material shall be held accurately and rigidly in place by means of cap nails provided for this purpose. The top of the expansion material shall be protected during paving operations by a 12 gage metal cap or shield designed to fit down over the expansion material a minimum distance of 1/2". The metal cap shall be removed immediately after the final pass of the finishing machine. When two adjacent lanes are poured simultaneously, the metal cap shall be continuous across the longitudinal joint.

The free ends of the dowels shall be equipped after greasing with a metal sleeve approximately 3" long, designed with a crimped end and overlapping seam which fits closely around the dowel. Provision shall be made by a depression or interior projection in the sleeve to act as a stop for the dowel 1" from the crimped end to allow for longitudinal dowel movement with pavement expansion.

Dowel holes 3/16" in diameter shall be punched or drilled into the expansion material to insure tight fitting dowels.

Joints in monolithic curbs shall be constructed of the same type of filler material as used in the expansion joints.

CONTRACTION AND CONSTRUCTION JOINTS:—A steel plate 1/8" thick shall be used in contraction and construction joints. The plate shall have 1/8" diameter holes punched to accommodate the 1" dowels. Additional anchor pins shall be used opposite the brace rods to hold the plate in place for contraction joints or the plate may be welded to the dowels.

The steel plate shall be held rigidly in place for construction joints in a manner that will provide a full depth joint perpendicular to the surface. A plate of sufficient stiffness and sloped to fit over the dowel bars shall be used adjacent to the metal plate and sufficiently well staked to hold the metal plate in correct position. This plate shall be removed prior to resumption of concreting operations.

The position of the dowel assembly shall be reversed for construction joints so that the free end of the dowel will point toward the direction of paving operations.

Contraction joints shall be spaced at intervals of 100' in reinforced Portland cement concrete pavement. Contraction joints will not be permitted in concrete base courses.

JOINT FINISHING:—Care shall be exercised in edging joints that the proper radius is maintained. Any impression left in the surface of the pavement by the flat part of the edging tool shall be eliminated, but in no case shall the addition of grout be permitted for this purpose. Final belt finish shall be applied to the pavement surface adjacent to joints as is required for the balance of the pavement area and particular attention shall be given to straight edging the pavement across joints to insure no difference in the elevation of the pavement surface on opposite sides of the joint.

POURED SEAL:—The material for poured seal shall meet the requirements of Section M-10.23, or Sup. Spec. M-110.25.

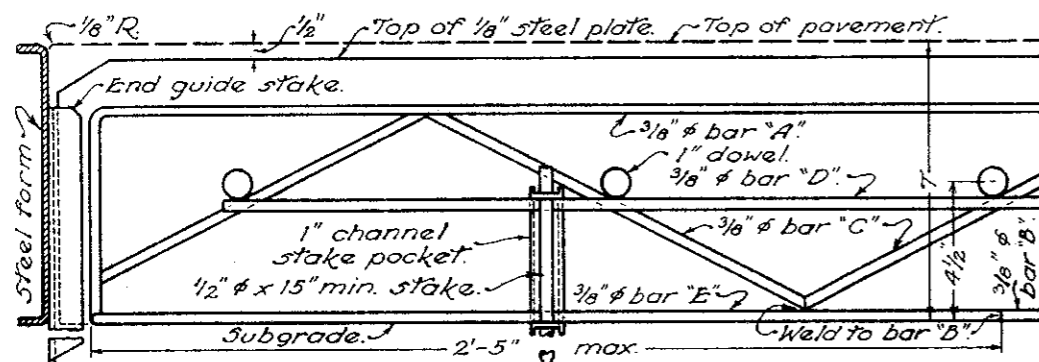

SIDE ELEVATION

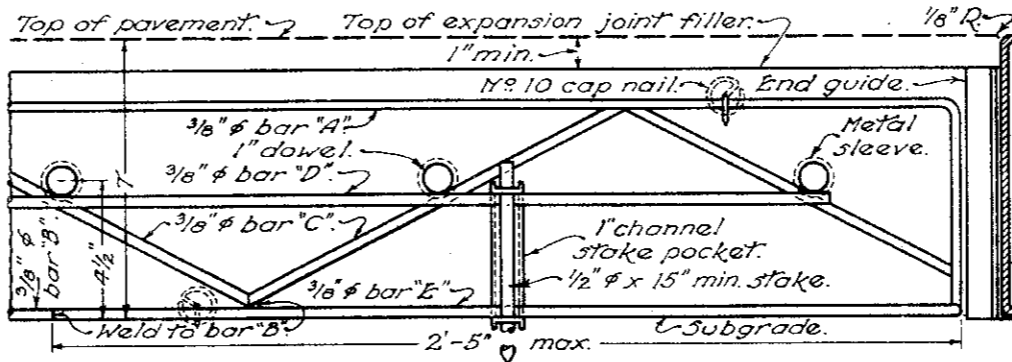

SIDE ELEVATION

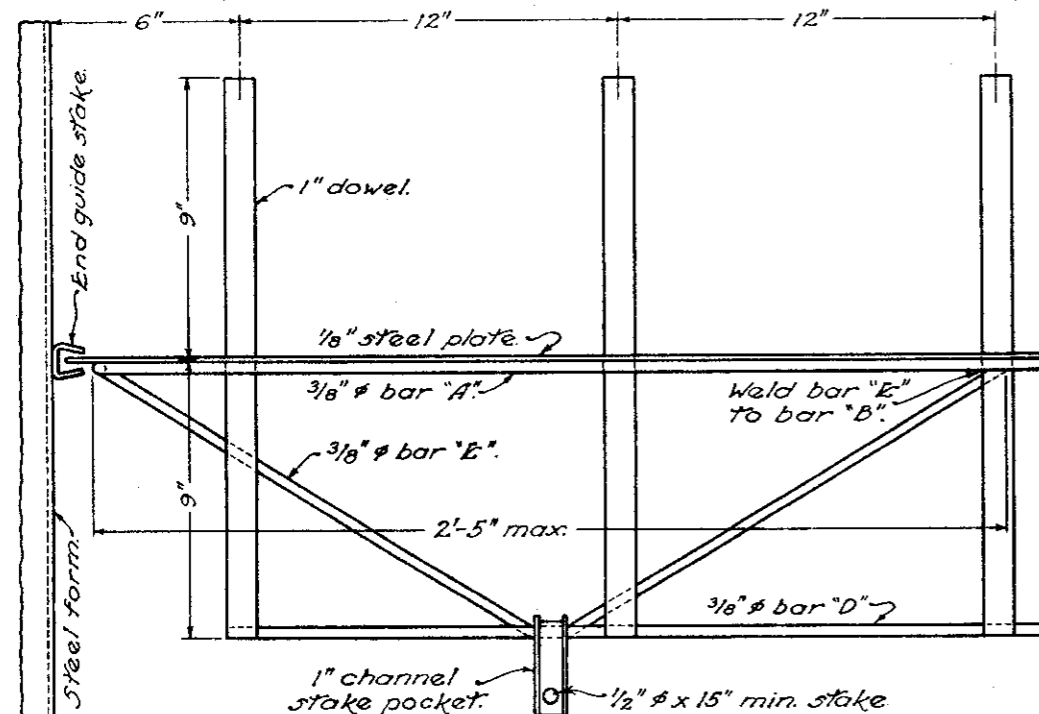

PLAN

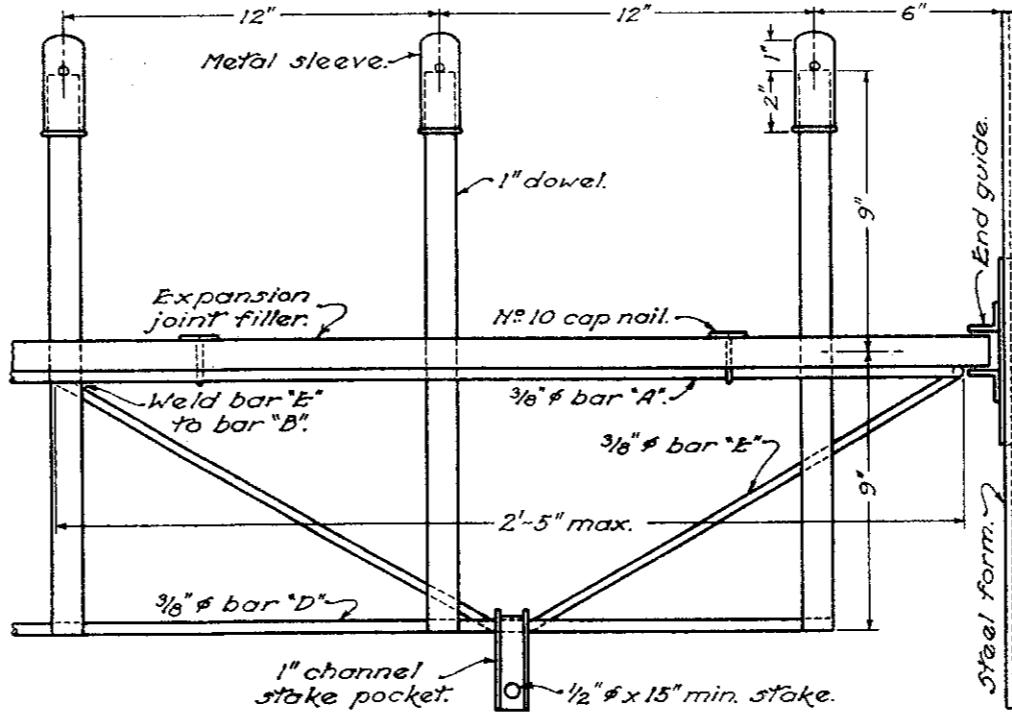

PLAN

The junction of all bars shall be welded. Dowels shall be welded to bars "C" and "D". Channels shall be welded to bars "D" and "E".

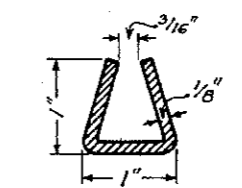

SECTION END GUIDE STAKE CONTR. JOINT

BUREAU OF LOCATION AND DESIGN
OHIO DEPARTMENT OF HIGHWAYS

DATE
2-7-50
7-1-50
1-2-51
8-1-51

PAVEMENT JOINTS

STANDARD CONSTRUCTION DRAWING
APPROVED *[Signature]* CHIEF ENGINEER

T. J. NO. 3

TRANSVERSE JOINTS

CONTRACTION JOINT

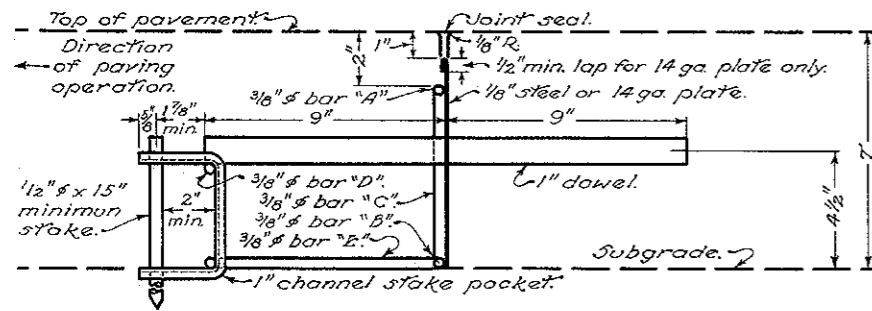

SECTION THROUGH JOINT

EXPANSION JOINT

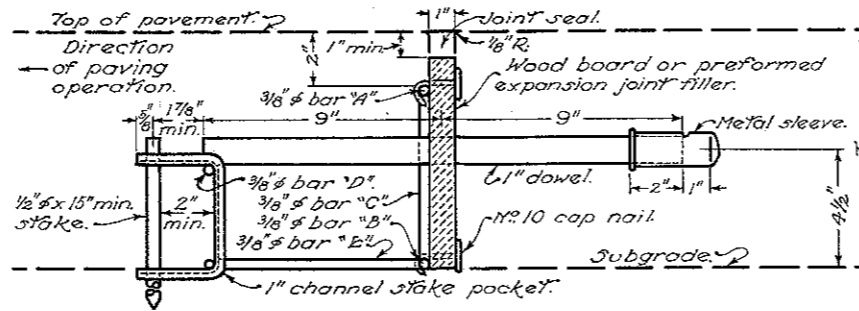

SECTION THROUGH JOINT

NOTES

GENERAL: The welded dowel assembly shall be shop fabricated in such a manner as to form a truss-like framework with sufficient strength to hold the dowels and joint filler or steel plate in proper position during concrete placing and finishing operations. The dowels shall be parallel to the surface and centerline of the pavement.

The entire joint assembly shall be shaped to fit the section of the pavement.

DOWELS: Load transfer device shall consist of 1" round, smooth, straight, steel dowel bars. The free ends of the dowels shall have a coating of either bituminous material SC-2 or 3 or an oil such as SAE 140 or equal, just prior to placing the concrete.

ASSEMBLY: The dowel bars shall be welded to the 1/8" "C" and "D" bars at the center and one end of the dowel as indicated in the detail.

The joint assembly shall be continuous between longitudinal joints or between longitudinal joint and pavement edge and shall be held in place by channel stake pockets securely spiked to the substrate. Stake pockets shall engage the joint assembly as shown and be spaced at intervals not to exceed 5'-0".

Dowel cages are dimensioned for pavement lanes of even foot widths. Where other widths are specified standard cages may be used with dowel spacings adjusted as follows:

The 6" dowel spacing shall be maintained at the longitudinal joint. The spacing of the outer edge of the lane may be increased up to 12" where an odd width of lane occurs and the dowel spacing at the outer edge of the lane, when using a standard cage, would exceed 12". A dowel shall be placed 6" from the outer edge of the lane and held rigidly in proper position by a method satisfactory to the Engineer, or a dowel cage of greater length than required may be used by cutting the assembly and splicing to obtain the required length.

In all cases, the steel plate or joint filler shall be full length for the width of the lane.

The joint assembly shown hereon is for use with uniform depth pavement. The joint assembly for variable depth pavement shall be in accordance with the design shown on the plans.

EXPANSION JOINTS: Wood board, Sec. M-10.03 and preformed expansion joint filler, Sec. M-10.02 shall be considered as alternates. The type used on any project is optional with the contractor.

Expansion joints shall be used only at intersections or designated on the plan, and at structures against which the pavement abuts. Two expansion joints shall be placed on each side of each structure at approximately 15 ft. and 65 ft. from the end of the approach slab or, in the case of skewed approach slab, 15 ft. and 65 ft. from the point of the approach slab farthest from the structure.

Expansion joints in concrete bases shall be used only when required by the plans.

Joint filler shall be held rigidly in position by means of cap nails provided for this purpose. The top of the joint filler shall be protected during paving operations by a 12 gage metal cap or shield designed to fit over the joint filler a minimum distance of 1". The metal cap shall be removed at such a time in the finishing operation that will enable the best workmanship in finishing the joint to the dimensions specified.

The free ends of the dowels shall be equipped with metal sleeves approximately 3" long designed with crimped ends and overlapping seams and which fit closely around the dowels. Provision shall be made by a depression or interior projection in the sleeve to act as a stop for the dowel sufficiently distant from the crimped end to allow 1" for longitudinal dowel movement with pavement expansion.

Dowel holes shall be punched or drilled into the joint filler of the proper size to insure tight fitting dowels.

Joints in monolithic curbs shall be constructed of the same type of filler material as used in the expansion joints.

CONTRACTION JOINTS: A steel plate 1/8" thick or No. 14 gage shall be used in contraction joints. The plate shall have holes so arranged and of proper size to fit snugly over the dowels. Additional anchor pins shall be used opposite the brace rods to hold the plate in place or the plate may be welded to the dowels or it may be held in position by 16 gage wire tied to the "A" and "E" bars through sets of two holes in the plate placed so the ties will be a maximum distance of 2 ft. apart and located directly above and below the "A" and "E" bars. Contraction joints shall be spaced at intervals of 60 ft. in reinforced Portland cement concrete pavement. Contraction joints will not be permitted in concrete base courses.

JOINT FINISHING: Care shall be exercised in edging joints that the proper radius is maintained. Any impression left in the surface of the pavement by the flat part of the edging tool shall be eliminated, but in no case will the addition of gravel be permitted for this purpose. Final belt finish shall be applied to the pavement surface adjacent to joints as is required for the balance of the pavement. Particular attention shall be given to straight edging the pavement across joints to insure no difference in the elevation of the pavement surface on opposite sides of the joints.

JOINT SEAL: The material for joint seal shall meet the requirements of Sec. M-10.23 or Sec. M-10.26.

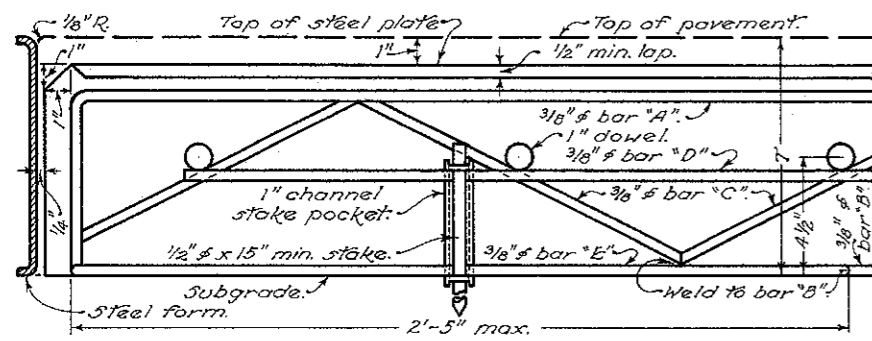

SIDE ELEVATION

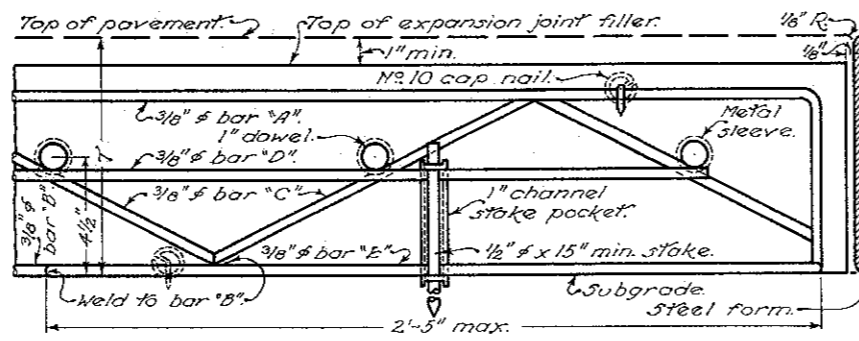

SIDE ELEVATION

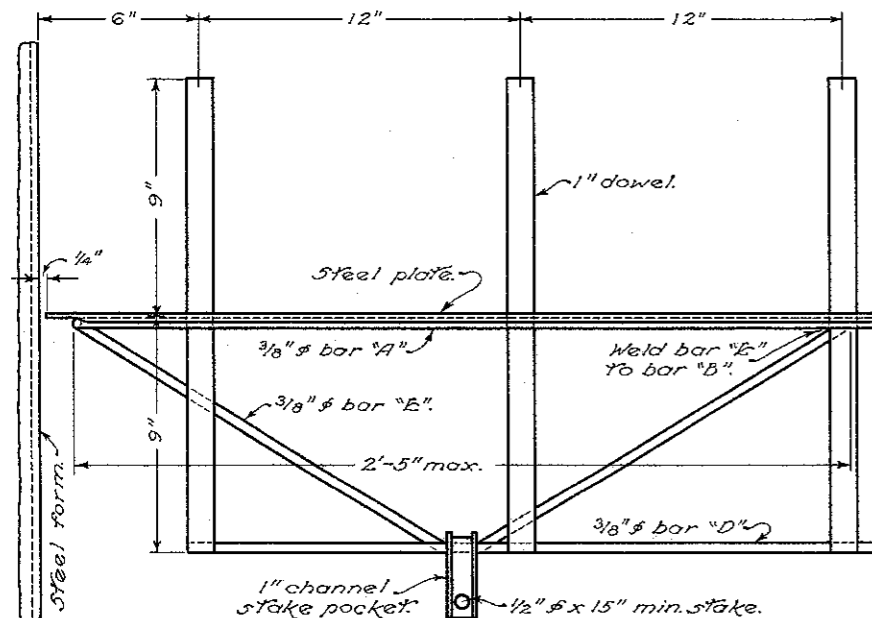

PLAN

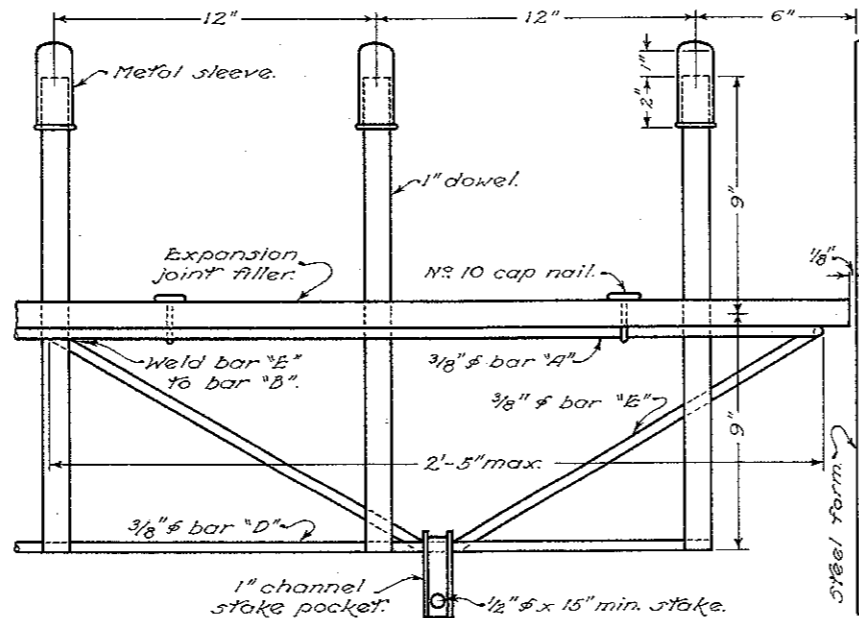

PLAN

The junction of all bars shall be welded. Dowels shall be welded to bars "C" and "D". Channels shall be welded to bars "D" and "E".

BUREAU OF LOCATION AND DESIGN OHIO DEPARTMENT OF HIGHWAYS	
PAVEMENT JOINTS	
STANDARD CONSTRUCTION DRAWING	T. J. NO. 3
APPROVED <i>[Signature]</i> CHIEF ENGINEER	

DATE
2-7-50
7-1-50
1-2-51
8-1-51
3-2-53

TRANSVERSE JOINTS

CONTRACTION JOINT

EXPANSION JOINT

NOTES

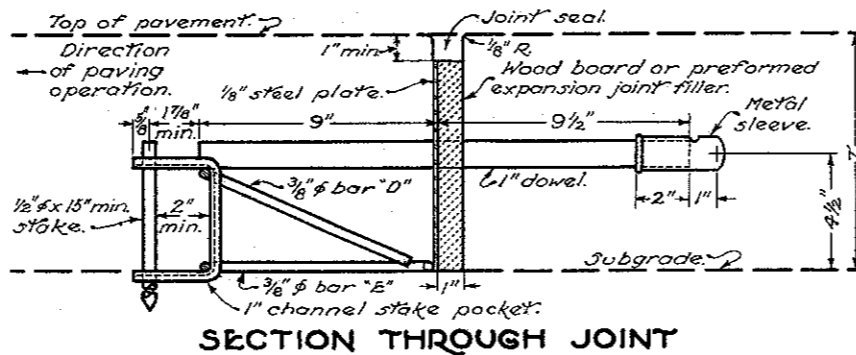
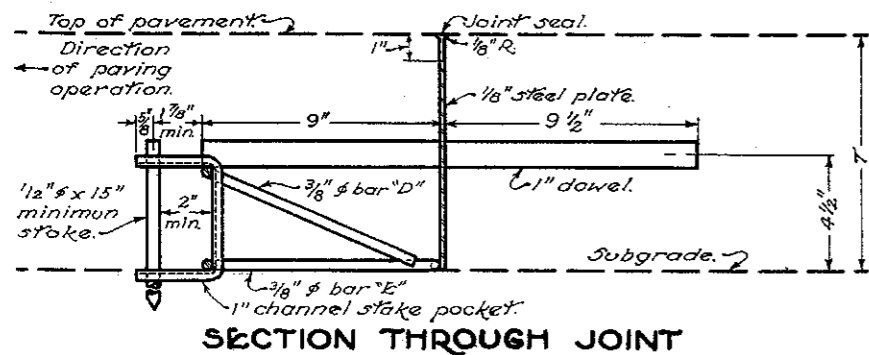

GENERAL:—The welded dowel assembly shall be shop fabricated in such a manner as to form a truss-like framework with sufficient strength to hold the dowels and joint filler or steel plate in proper position during concrete placing and finishing operations. The dowels shall be parallel to the surface and centerline of the pavement.

The entire joint assembly shall be shaped to fit the section of the pavement.

DOWELS:—Load transfer device shall consist of 1" round, smooth, straight, steel dowel bars. The free ends of the dowels shall have a coating of either bituminous material SC-2 or 3 or an oil such as SAE 140 or equal, just prior to placing the concrete.

ASSEMBLY:—The dowel bars shall be welded to the 1/8" steel plate and the 3/8" "D" bar as indicated in the detail.

The joint assembly shall be continuous between longitudinal joints or between longitudinal joint and pavement edge and shall be held in place by channel stake pockets securely staked to the subgrade. Stake pockets shall engage the joint assembly as shown and be spaced at intervals not to exceed 4'-0".

Dowel cages are dimensioned for pavement lanes of even foot widths. Where other widths are specified standard cages may be used with dowel spacings adjusted as follows:

The 6" dowel spacing shall be maintained at the longitudinal joint. The spacing at the outer edge of the lane may be increased up to 12". Where an odd width of lane occurs and the dowel spacing at the outer edge of the lane, when using a standard cage, would exceed 12" a dowel shall be placed 6" from the outer edge of the lane and held rigidly in proper position by a method satisfactory to the Engineer or a dowel cage of greater length than required may be used by cutting the assembly and splicing to attain the required length.

In all cases, the steel plate or joint filler shall be full length for the width of the lane.

The joint assembly shown hereon is for use with uniform depth pavement. The joint assembly for variable depth pavement shall be in accordance with the design shown on the plans.

EXPANSION JOINTS:—Wood board, Sec. M-10.03 and preformed expansion joint filler, Sec. M-10.02 shall be considered as alternates. The type used on any project is optional with the contractor.

Expansion joints shall be used only at intersections as designated on the plan, and at structures against which the pavement abuts. Two expansion joints shall be placed on each side of each structure at approximately 15 ft. and 65 ft. from the end of the approach slab or, in the case of skewed approach slab, 15 ft. and 65 ft. from the point of the approach slab farthest from the structure.

Expansion joints in concrete bases shall be used only when required by the plans.

Joint filler shall be held rigidly in position by means of a No. 12 gage metal cap as detailed. The metal cap shall be removed at such a time in the finishing operation that will enable the best workmanship in finishing the joint to the dimensions specified.

The free ends of the dowels shall be equipped after greasing with metal sleeves approximately 3" long designed with crimped ends and overlapping seams and which fit closely around the dowels. Provision shall be made by a depression or interior projection in the sleeve to act as a stop for the dowel sufficiently distant from the crimped end to allow 1" for longitudinal dowel movement with pavement expansion.

Dowel holes shall be punched or drilled into the joint filler of the proper size to insure tight fitting dowels.

Joints in monolithic curbs shall be constructed of the same type of filler material as used in the expansion joints.

CONTRACTION JOINTS:—A steel plate 1/8" thick shall be used in contraction joints. The plate shall have holes so arranged and of proper size to fit snugly over the dowels.

Contraction joints shall be spaced at intervals of 60 ft. in reinforced Portland cement concrete pavement. Contraction joints will not be permitted in concrete base courses.

JOINT FINISHING:—Care shall be exercised in edging joints that the proper radius is maintained. Any impression left in the surface of the pavement by the flat part of the edging tool shall be eliminated, but in no case will the addition of grout be permitted for this purpose. Final belt finish shall be applied to the pavement surface adjacent to joints as is required for the balance of the pavement. Particular attention shall be given to straight edging the pavement across joints to insure no difference in the elevation of the pavement surface on opposite sides of the joints.

JOINT SEAL:—The material for joint seal shall meet the requirements of Sec. M-10.23 or Sec. M-10.26.

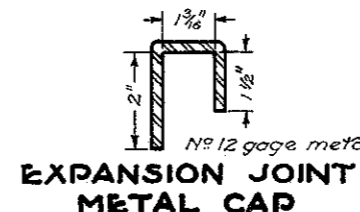
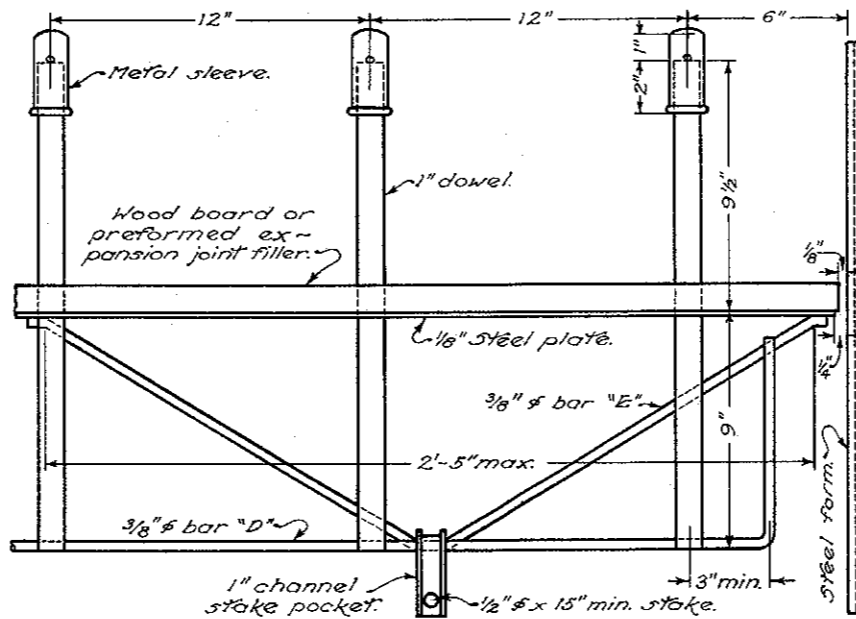
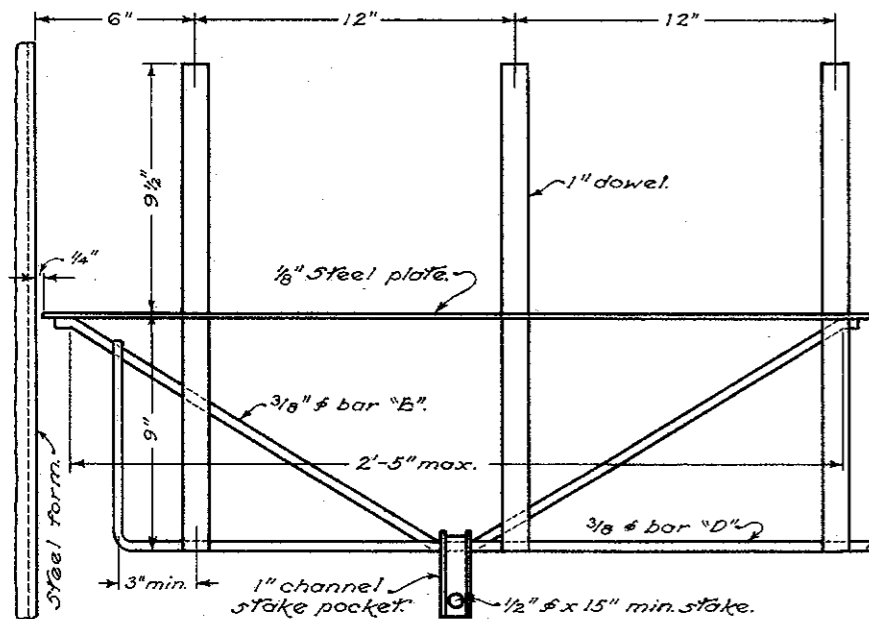
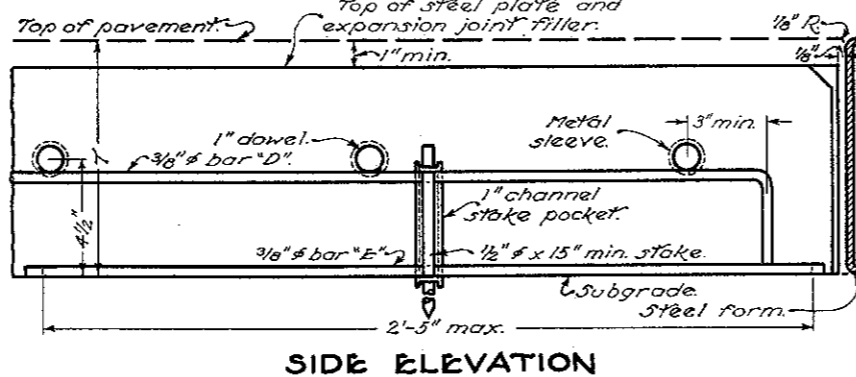
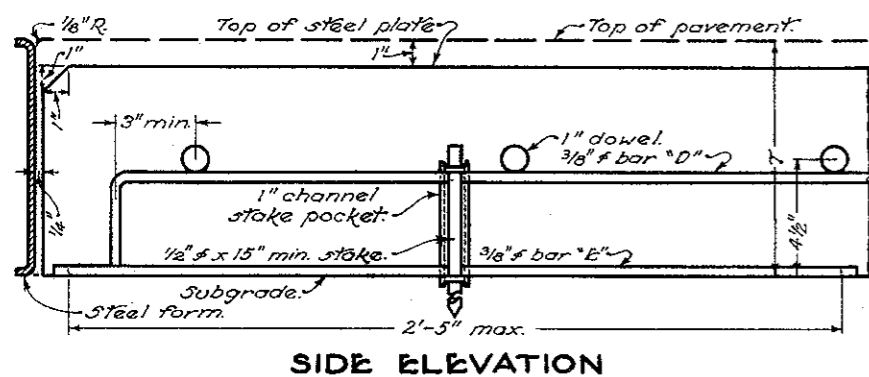

WELD bar "D" to bar "E", bar "E" to steel plate, dowels to bar "D" and steel plate, and channels to bars "D" and "E".

BUREAU OF LOCATION AND DESIGN OHIO DEPARTMENT OF HIGHWAYS	
PAVEMENT JOINTS	
STANDARD CONSTRUCTION DRAWING	T. J. No. 3 ENGINEER LOCATION & DESIGN
APPROVED <i>K.R.</i>	
DATE: 2-7-50 7-1-50 1-2-51 8-1-51 3-2-53 10-1-54	