

FEDERAL-AID CONSTRUCTION IDENTIFICATION SIGNS

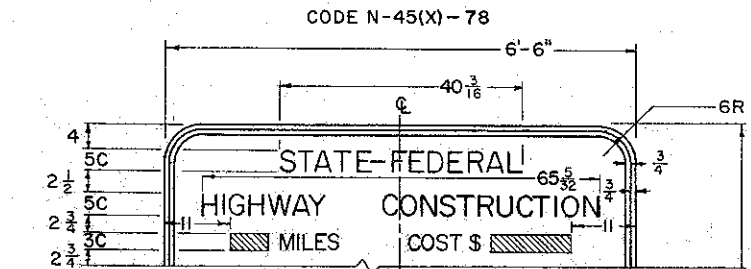

UPPER PORTION OF SIGN ABOVE IS TO BE USED WITH APPROPRIATE LOWER PORTION OF SIGN FOUND BELOW.

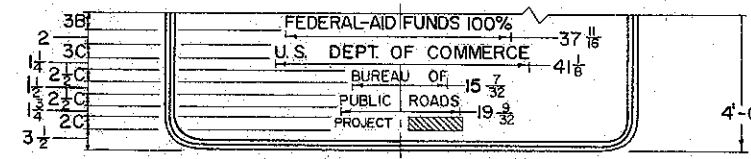

N-45(1)-78

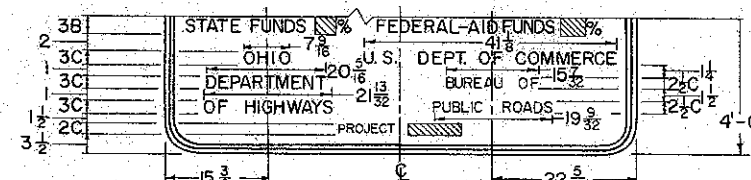

N-45(2)-78

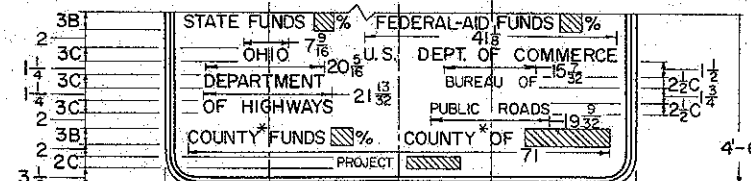

N-45(3)-78

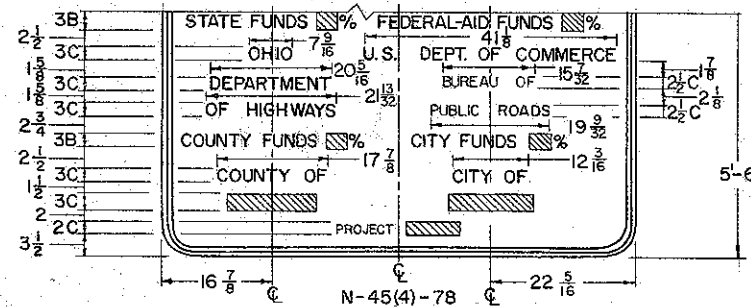

N-45(4)-78

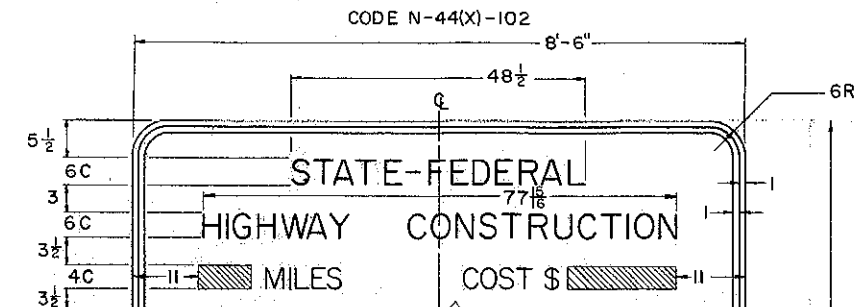

UPPER PORTION OF SIGN ABOVE IS TO BE USED WITH APPROPRIATE LOWER PORTION OF SIGN FOUND BELOW.

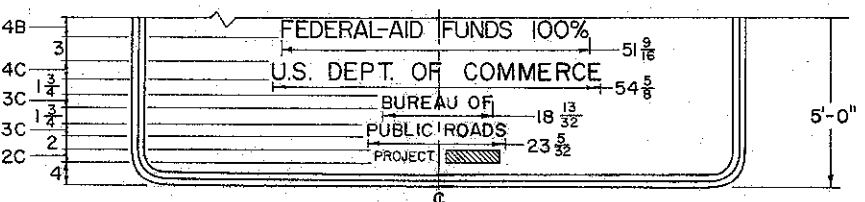

N-44(1)-102

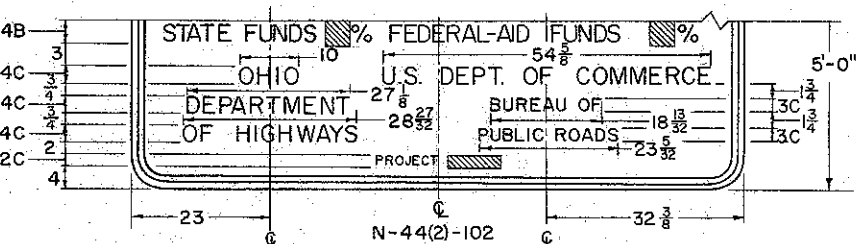

N-44(2)-102

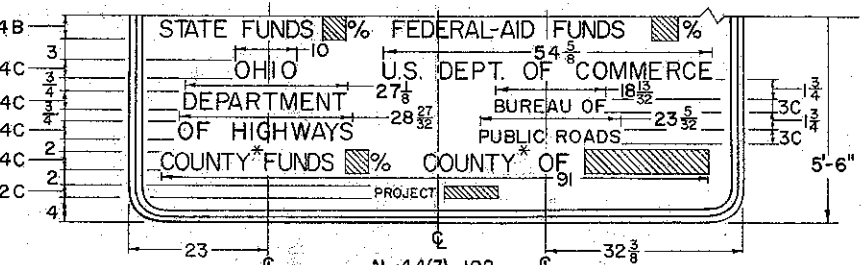

N-44(3)-102

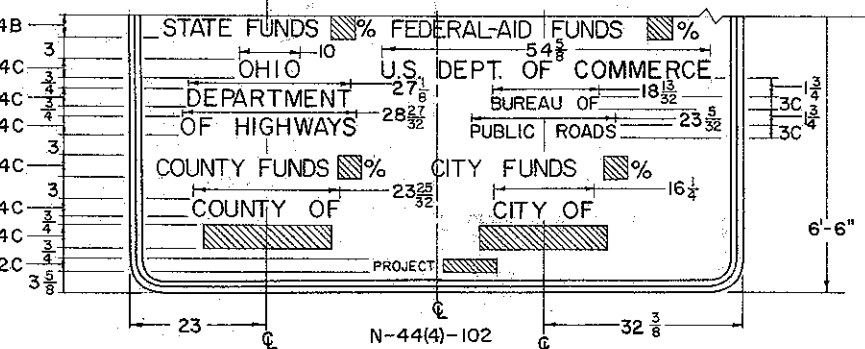

N-44(4)-102

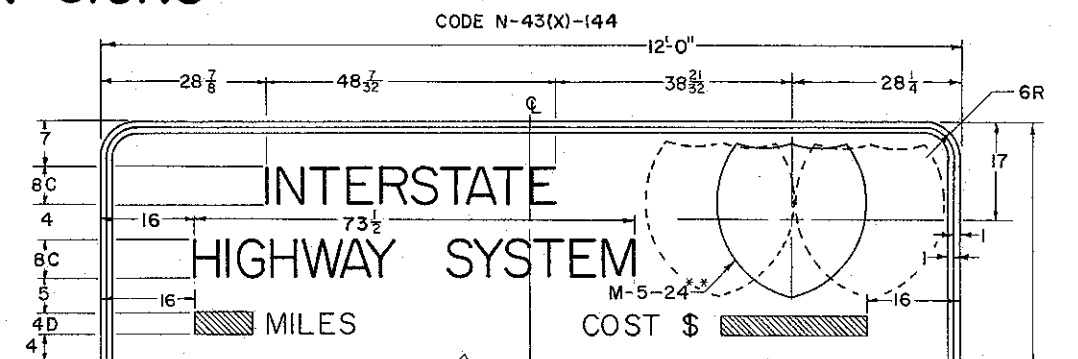

UPPER PORTION OF SIGN ABOVE IS TO BE USED WITH APPROPRIATE LOWER PORTION OF SIGN FOUND BELOW.

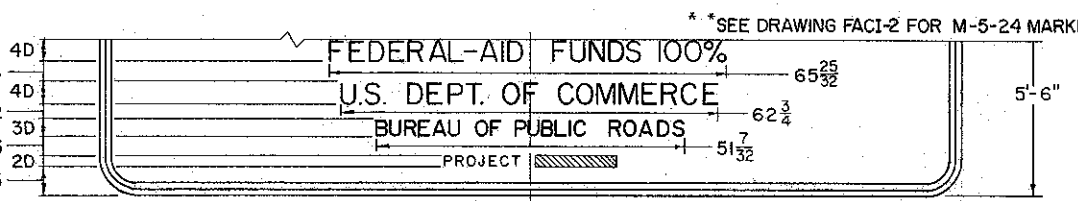

N-43(1)-144

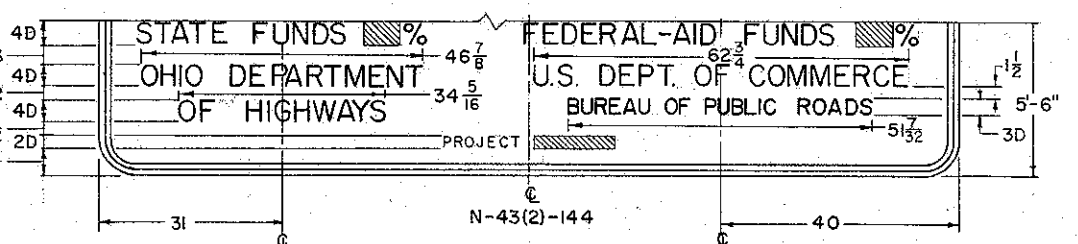

N-43(2)-144

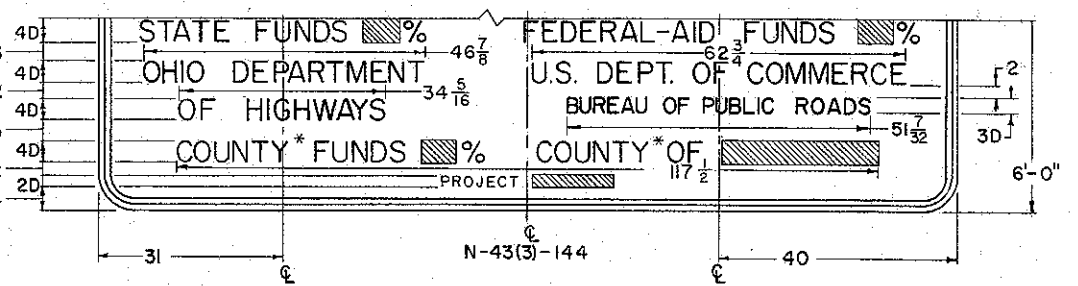

N-43(3)-144

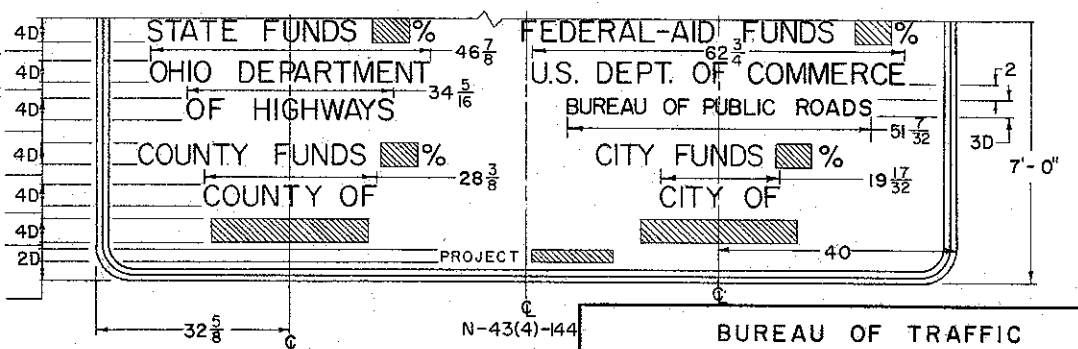

N-43(4)-144

NOTES:
ALPHABET AND LETTER SPACING SIGN LETTERING, WHEN INDICATED ON THE PLANS AS A SERIES TYPE SUCH AS 4C OR 4D, SHALL BE DESIGNED IN ACCORDANCE WITH THE "STANDARD ALPHABETS FOR HIGHWAY SIGNS OF THE BUREAU OF PUBLIC ROADS". THE SPACING BETWEEN LETTERS IS INDICATED IN THE "OHIO MANUAL OF UNIFORM TRAFFIC CONTROL DEVICES" AND IS TO BE INCREASED OR DECREASED PROPORTIONALLY SO THAT THE LEGEND

OCCUPIES THE DIMENSION INDICATED ON THE PLANS. COPIES OF THE ABOVE REFERENCE ARE ON FILE IN THE OFFICE OF THE DEPARTMENT OF HIGHWAYS, BUREAU OF TRAFFIC.
SIGN MATERIAL:
SIGN MATERIAL SHALL BE 1/2 INCH PLYWOOD IN ACCORDANCE WITH SECTION I-128.02(1) OF SUPPLEMENTAL SPECIFICATION I-128.

SIGN COLORS
SIGN BACKGROUND COLOR SHALL BE WHITE ENAMEL IN ACCORDANCE WITH SECTION I-128.02(5). SIGN LEGEND AND BORDER SHALL BE BLACK SILK SCREEN PASTE IN ACCORDANCE WITH SECTION I-128.02(6)(A).
*THE WORD COUNTY SHALL BE REPLACED BY THE WORD CITY WHEN APPROPRIATE.

QUANTITY, LOCATION, AND TYPE OF FEDERAL-AID CONSTRUCTION IDENTIFICATION SIGNS IS SPECIFIED IN THE GENERAL NOTES.
CROSSHATCHED AREA DENOTES A VARIABLE THAT SHALL BE FURNISHED AT THE TIME OF CONSTRUCTION.
ALL DIMENSIONS ARE IN INCHES UNLESS OTHERWISE NOTED.

BUREAU OF TRAFFIC
OHIO DEPARTMENT OF HIGHWAYS

FEDERAL AID CONSTRUCTION IDENTIFICATION SIGNS	FACI-1	DATE 8-25-61 12-27-61
APPROVED <i>R. E. Cooney</i> ENGINEER OF TRAFFIC		

FEDERAL-AID CONSTRUCTION IDENTIFICATION SIGNS

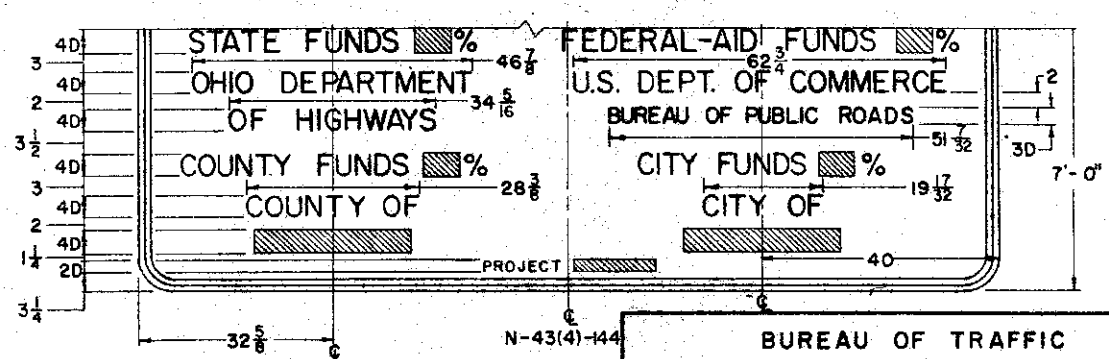
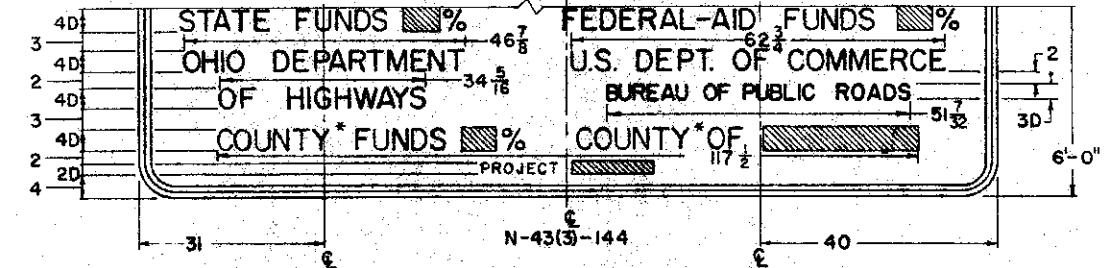
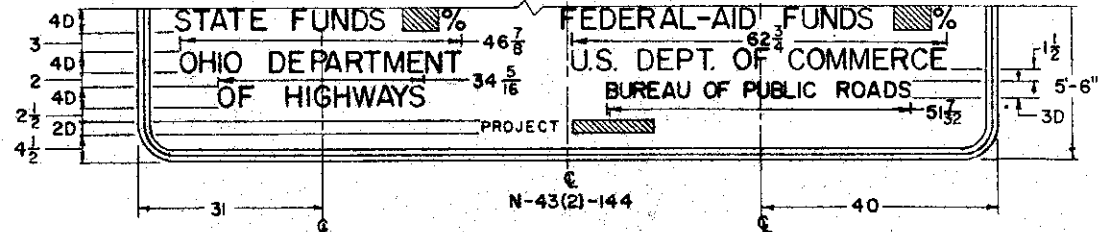
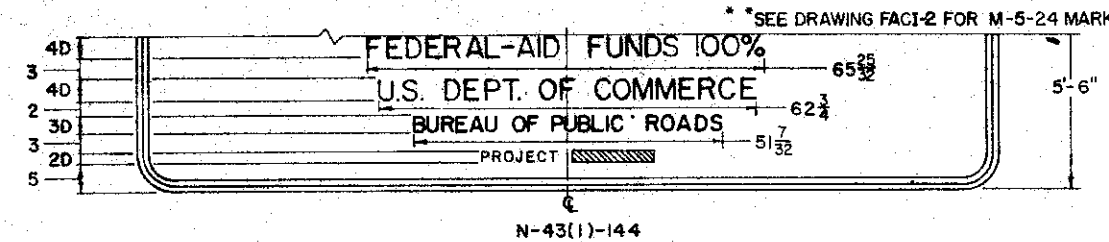
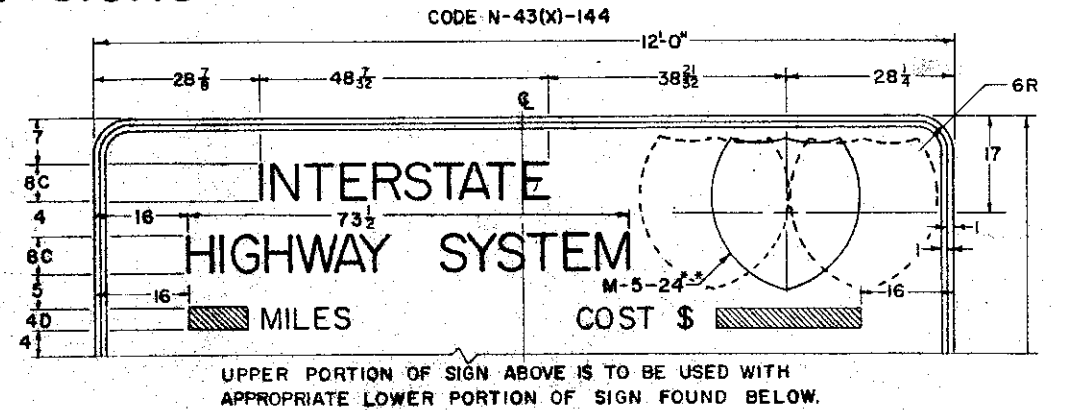
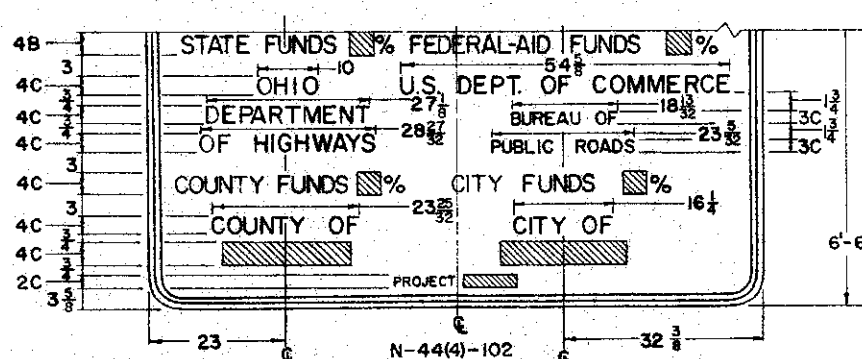
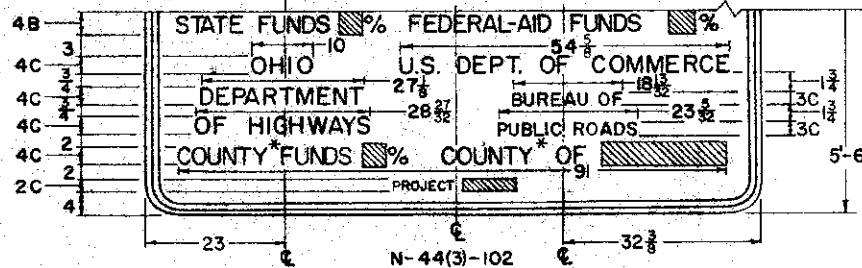
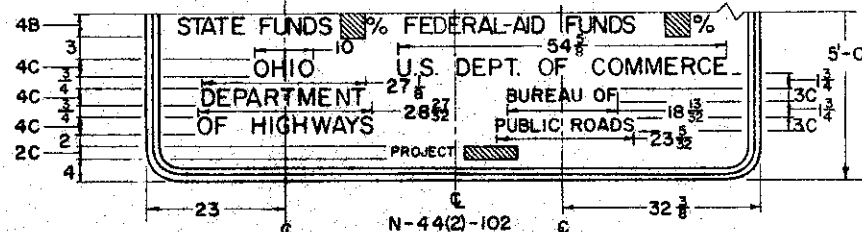
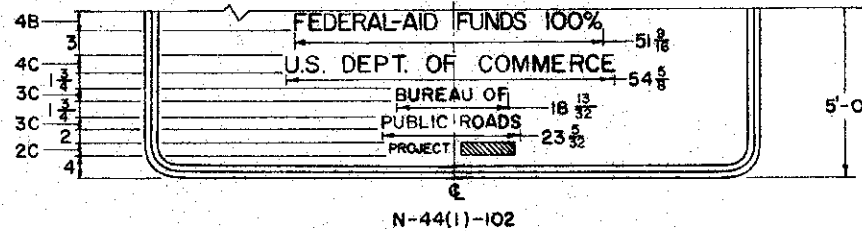
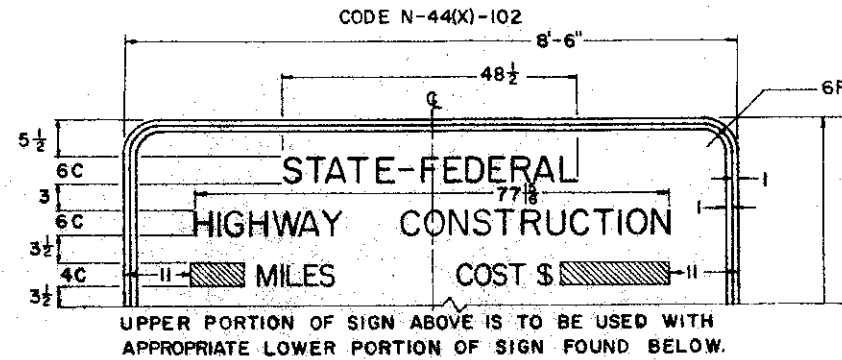
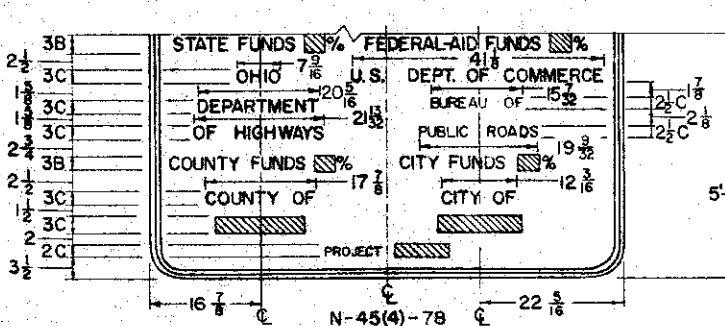
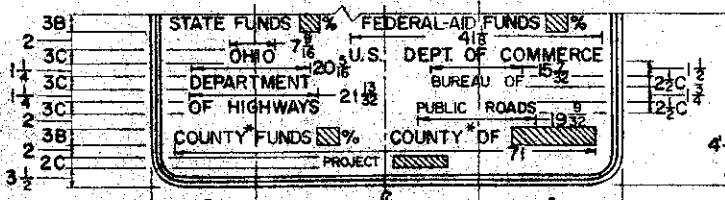
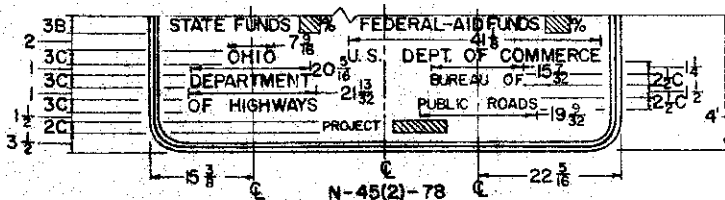
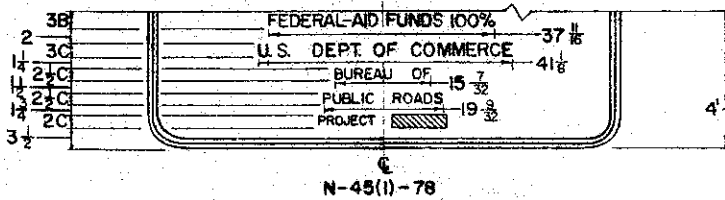
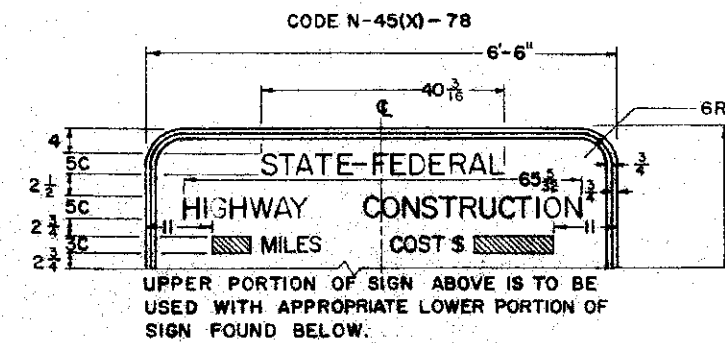

NOTES:
ALPHABET AND LETTER SPACING
SIGN LETTERING, WHEN INDICATED ON THE PLANS AS A SERIES TYPE SUCH AS 4C OR 4D, SHALL BE DESIGNED IN ACCORDANCE WITH THE STANDARD ALPHABETS FOR HIGHWAY SIGNS OF THE BUREAU OF PUBLIC ROADS. THE SPACING BETWEEN LETTERS IS INDICATED IN THE "OHIO MANUAL OF UNIFORM TRAFFIC CONTROL DEVICES" AND IS TO BE INCREASED OR DECREASED PROPORTIONALLY SO THAT THE LEGEND

OCCUPIES THE DIMENSION INDICATED ON THE PLANS. COPIES OF THE ABOVE REFERENCE ARE ON FILE IN THE OFFICE OF THE DEPARTMENT OF HIGHWAYS, BUREAU OF TRAFFIC, 450 E. TOWN ST., COLUMBUS, OHIO.
SIGN MATERIAL:
SIGN MATERIAL SHALL BE 1/2 INCH HIGH OR MEDIUM-DENSITY RESIN IMPREGNATED FIBER OVERLAID PLYWOOD. IT SHALL BE DOUGLAS FIR EXTERIOR TYPE AND SHALL CONFORM TO COMMERCIAL STANDARD CS45-60, GRADE B OR BETTER.

SIGN COLORS
SIGN BACKGROUND COLOR SHALL BE WHITE USING TWO COATS OF ENAMEL MEETING SEC. M-9.13 MODIFIED AS FOLLOWS:
PIGMENT - ALL PIGMENT SHALL BE RUTILE NON-CHALKING TITANIUM DIOXIDE (MEETING FEDERAL SPECIFICATION TT-T-425a TYPE III).
FINISHED ENAMEL -
PIGMENT
LIQUID (CONTAINING AT LEAST 40% NON-VOLATILE)
WEIGHT PER GALLON
SIGN LEGEND AND BORDER SHALL BE BLACK USING A HIGH QUALITY BLACK OPAQUE SILK SCREEN PASTE OR BLACK ENAMEL MEETING SEC. M-9.14.

	MAXIMUM	MINIMUM
PIGMENT	26%	23%
LIQUID (CONTAINING AT LEAST 40% NON-VOLATILE)	77%	74%
WEIGHT PER GALLON		9.1 lbs.

QUANTITY, LOCATION, AND TYPE OF FEDERAL-AID CONSTRUCTION IDENTIFICATION SIGNS IS SPECIFIED IN THE GENERAL NOTES.
CROSSHATCHED AREA DENOTES A VARIABLE THAT SHALL BE FURNISHED AT THE TIME OF CONSTRUCTION.
ALL DIMENSIONS ARE IN INCHES UNLESS OTHERWISE NOTED.
*THE WORD COUNTY SHALL BE REPLACED BY THE WORD CITY WHEN APPROPRIATE.

BUREAU OF TRAFFIC
OHIO DEPARTMENT OF HIGHWAYS

FEDERAL AID CONSTRUCTION IDENTIFICATION SIGNS

STANDARD CONSTRUCTION DRAWING
APPROVED *Fred Clark*
ENGINEER OF TRAFFIC

DATE 3-8-63

FACT-1

FEDERAL-AID CONSTRUCTION IDENTIFICATION SIGNS

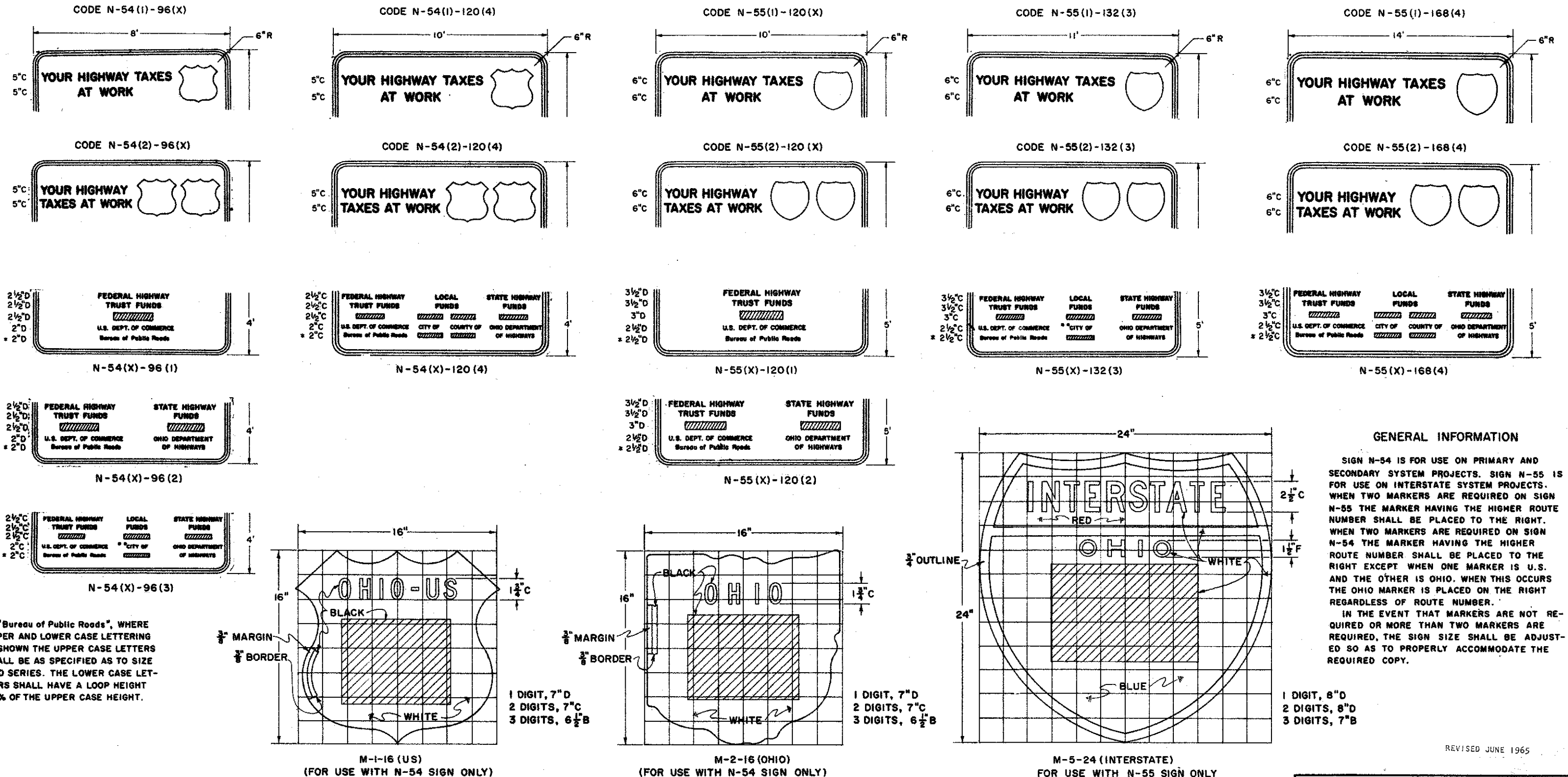

* IN "Bureau of Public Roads", WHERE UPPER AND LOWER CASE LETTERING IS SHOWN THE UPPER CASE LETTERS SHALL BE AS SPECIFIED AS TO SIZE AND SERIES. THE LOWER CASE LETTERS SHALL HAVE A LOOP HEIGHT 75% OF THE UPPER CASE HEIGHT.

NOTES:
ALPHABET AND LETTER SPACING
 SIGN LETTERING, WHEN INDICATED ON THE PLANS AS A SERIES TYPE SUCH AS 5C OR 6C SHALL BE DESIGNED IN ACCORDANCE WITH THE "STANDARD ALPHABETS FOR HIGHWAY SIGNS OF THE BUREAU OF PUBLIC ROADS". THE SPACING BETWEEN LETTERS IS INDICATED IN THE "OHIO MANUAL OF UNIFORM TRAFFIC CONTROL DEVICES" AND IS TO BE INCREASED OR DECREASED PROPORTIONALLY SO THAT THE LEGEND

OCCUPIES THE PROPER SPACE.
 COPIES OF THE ABOVE REFERENCE ARE ON FILE IN THE OFFICE OF THE DEPARTMENT OF HIGHWAYS, BUREAU OF TRAFFIC, 450 E. TOWN ST., COLUMBUS, OHIO.
SIGN MATERIAL
 SIGN MATERIAL SHALL BE 1/2 INCH HIGH OR MEDIUM-DENSITY RESIN IMPREGNATED FIBER OVERLAID PLYWOOD. IT SHALL BE DOUGLAS FIR EXTERIOR TYPE AND SHALL CONFORM TO COMMERCIAL STANDARD CS45-60, GRADE B OR BETTER.

SIGN COLORS
 SIGN BACKGROUND COLOR SHALL BE WHITE USING TWO COATS OF ENAMEL MEETING SEC. M-9.13 MODIFIED AS FOLLOWS:
 PIGMENT - ALL PIGMENT SHALL BE RUTILE NON-CHALKING TITANIUM DIOXIDE (MEETING FEDERAL SPECIFICATION TT-T-425a TYPE III).
 FINISHED ENAMEL -

	MAXIMUM	MINIMUM
PIGMENT	26%	23%
LIQUID (CONTAINING AT LEAST 40% NON-VOLATILE)	77%	74%
WEIGHT PER GALLON	—	9.1 lbs.

SIGN LEGEND AND BORDER SHALL BE BLACK USING A HIGH QUALITY BLACK OPAQUE SILK SCREEN PASTE OR BLACK ENAMEL MEETING SEC. M-9.14.

QUANTITY, LOCATION, AND TYPE OF FEDERAL AID CONSTRUCTION IDENTIFICATION SIGNS IS SPECIFIED IN THE GENERAL NOTES.
 CROSSHATCHED AREA DENOTES A VARIABLE THAT SHALL BE FURNISHED AT THE TIME OF CONSTRUCTION.
 ** THE WORD CITY SHALL BE REPLACED BY THE WORD COUNTY WHEN APPROPRIATE.

GENERAL INFORMATION

SIGN N-54 IS FOR USE ON PRIMARY AND SECONDARY SYSTEM PROJECTS. SIGN N-55 IS FOR USE ON INTERSTATE SYSTEM PROJECTS. WHEN TWO MARKERS ARE REQUIRED ON SIGN N-55 THE MARKER HAVING THE HIGHER ROUTE NUMBER SHALL BE PLACED TO THE RIGHT. WHEN TWO MARKERS ARE REQUIRED ON SIGN N-54 THE MARKER HAVING THE HIGHER ROUTE NUMBER SHALL BE PLACED TO THE RIGHT EXCEPT WHEN ONE MARKER IS U.S. AND THE OTHER IS OHIO. WHEN THIS OCCURS THE OHIO MARKER IS PLACED ON THE RIGHT REGARDLESS OF ROUTE NUMBER.
 IN THE EVENT THAT MARKERS ARE NOT REQUIRED OR MORE THAN TWO MARKERS ARE REQUIRED, THE SIGN SIZE SHALL BE ADJUSTED SO AS TO PROPERLY ACCOMMODATE THE REQUIRED COPY.

1 DIGIT, 8"D
 2 DIGITS, 8"D
 3 DIGITS, 7"B

REVISED JUNE 1965

BUREAU OF TRAFFIC OHIO DEPARTMENT OF HIGHWAYS	
FEDERAL-AID CONSTRUCTION IDENTIFICATION SIGNS	DATE 3-8-63 2-25-64
STANDARD CONSTRUCTION DRAWING	FACI-1
APPROVED <i>[Signature]</i> ENGINEER OF TRAFFIC	

FEDERAL-AID CONSTRUCTION IDENTIFICATION SIGNS

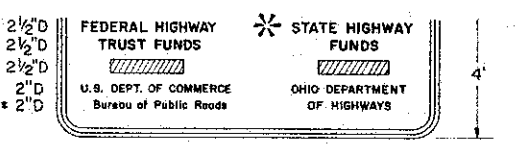
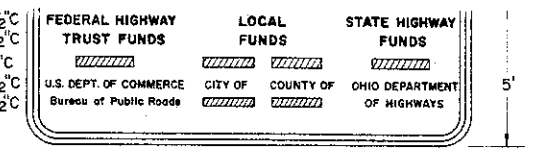
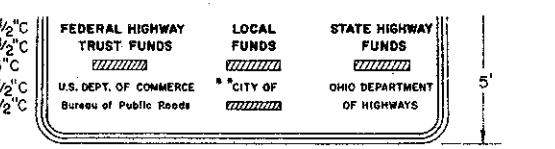
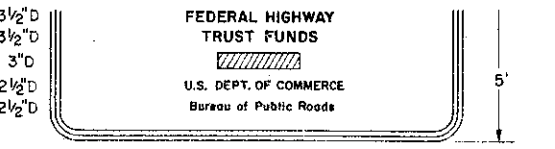
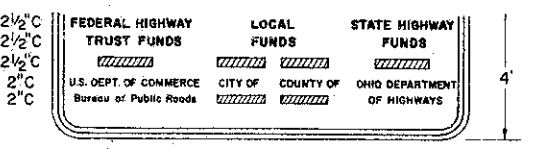
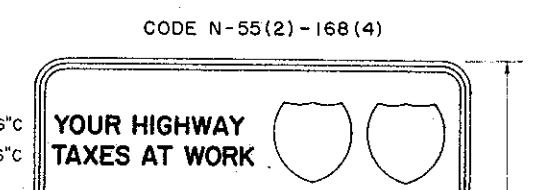
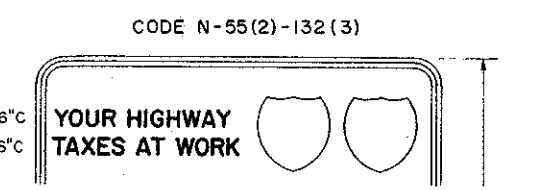
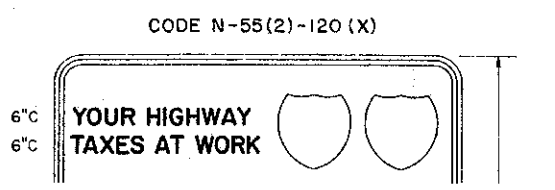
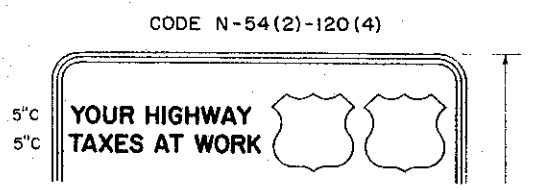
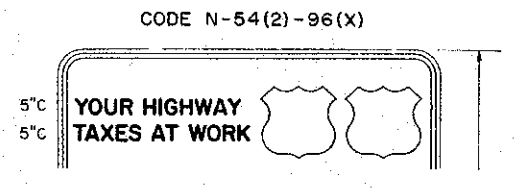
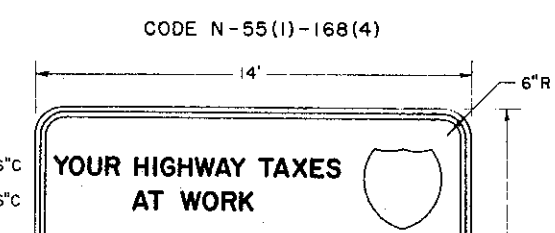
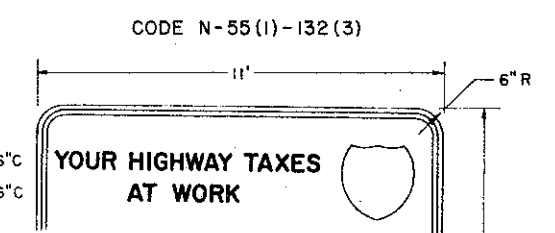
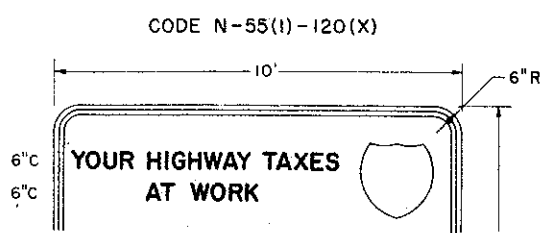
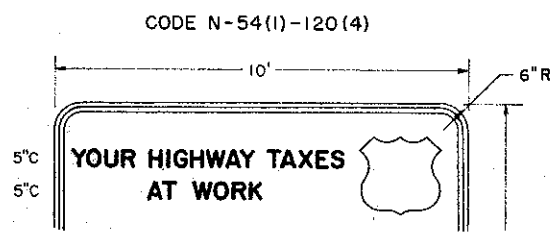
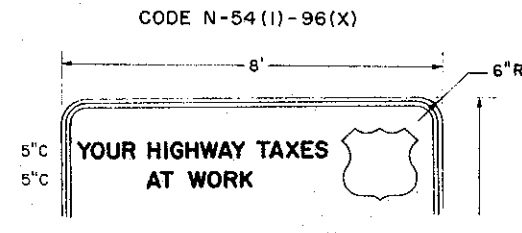

* THE WORD "STATE" SHALL BE REPLACED BY THE WORD "COUNTY", AND "OHIO DEPARTMENT OF" BY "COUNTY OF" WHEN APPROPRIATE.

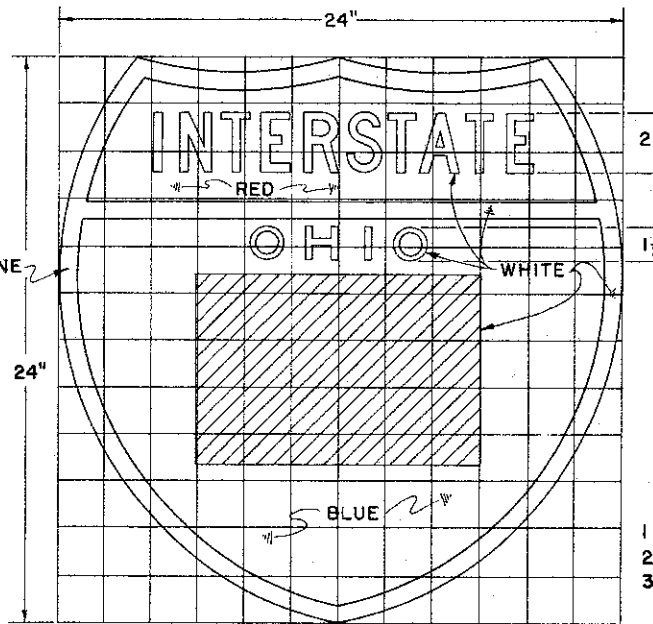
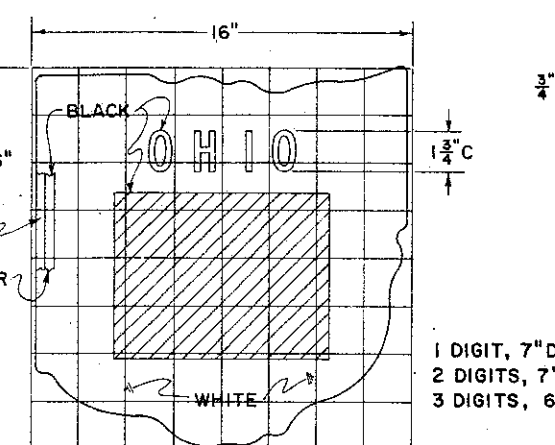
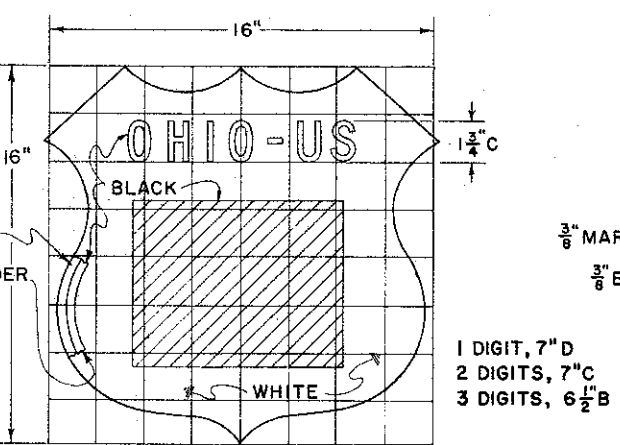
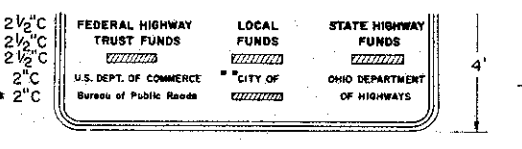
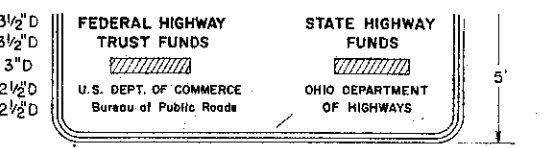

GENERAL INFORMATION

SIGN N-54 IS FOR USE ON PRIMARY AND SECONDARY SYSTEM PROJECTS. SIGN N-55 IS FOR USE ON INTERSTATE SYSTEM PROJECTS. WHEN TWO MARKERS ARE REQUIRED ON SIGN N-55 THE MARKER HAVING THE HIGHER ROUTE NUMBER SHALL BE PLACED TO THE RIGHT. WHEN TWO MARKERS ARE REQUIRED ON SIGN N-54 THE MARKER HAVING THE HIGHER ROUTE NUMBER SHALL BE PLACED TO THE RIGHT EXCEPT WHEN ONE MARKER IS U.S. AND THE OTHER IS OHIO. WHEN THIS OCCURS THE OHIO MARKER IS PLACED ON THE RIGHT REGARDLESS OF ROUTE NUMBER.

IN THE EVENT THAT MARKERS ARE NOT REQUIRED OR MORE THAN TWO MARKERS ARE REQUIRED, THE SIGN SIZE SHALL BE ADJUSTED SO AS TO PROPERLY ACCOMMODATE THE REQUIRED COPY.

1 DIGIT, 8" D
2 DIGITS, 8" D
3 DIGITS, 7" B

* IN "Bureau of Public Roads", WHERE UPPER AND LOWER CASE LETTERING IS SHOWN THE UPPER CASE LETTERS SHALL BE AS SPECIFIED AS TO SIZE AND SERIES. THE LOWER CASE LETTERS SHALL HAVE A LOOP HEIGHT 75% OF THE UPPER CASE HEIGHT.

NOTES:

ALPHABET AND LETTER SPACING
SIGN LETTERING, WHEN INDICATED ON THE PLANS AS A SERIES TYPE SUCH AS 5C OR 6C SHALL BE DESIGNED IN ACCORDANCE WITH THE "STANDARD ALPHABETS FOR HIGHWAY SIGNS OF THE BUREAU OF PUBLIC ROADS". THE SPACING BETWEEN LETTERS IS INDICATED IN THE "OHIO MANUAL OF UNIFORM TRAFFIC CONTROL DEVICES" AND IS TO BE INCREASED OR DECREASED PROPORTIONALLY SO THAT THE LEGEND

OCCUPIES THE PROPER SPACE. COPIES OF THE ABOVE REFERENCE ARE ON FILE IN THE OFFICE OF THE DEPARTMENT OF HIGHWAYS, BUREAU OF TRAFFIC, 450 E. TOWN ST., COLUMBUS, OHIO.
SIGN MATERIAL
SIGN MATERIAL SHALL BE 1/2 INCH HIGH OR MEDIUM-DENSITY RESIN IMPREGNATED FIBER OVERLAID PLYWOOD. IT SHALL BE DOUGLAS FIR EXTERIOR TYPE AND SHALL CONFORM TO COMMERCIAL STANDARD CS45-60, GRADE B OR BETTER.

SIGN COLORS
SIGN BACKGROUND COLOR SHALL BE WHITE USING TWO COATS OF ENAMEL. ENAMELS SHALL CONFORM TO FSS TT-E-489 C, CLASS A, AIR-DRYING. SIGN LEGEND AND BORDER SHALL BE BLACK OPAQUE SILK SCREEN PASTE OR BLACK ENAMEL.

QUANTITY, LOCATION, AND TYPE OF FEDERAL AID CONSTRUCTION IDENTIFICATION SIGNS IS SPECIFIED IN THE GENERAL NOTES.
CROSSHATCHED AREA DENOTES A VARIABLE THAT SHALL BE FURNISHED AT THE TIME OF CONSTRUCTION.
** THE WORD CITY SHALL BE REPLACED BY THE WORD COUNTY WHEN APPROPRIATE.

BUREAU OF TRAFFIC
OHIO DEPARTMENT OF HIGHWAYS

FEDERAL-AID CONSTRUCTION IDENTIFICATION SIGNS

STANDARD CONSTRUCTION DRAWING

FACI-1

APPROVED *Frederick J. Dabbs*
ENGINEER OF TRAFFIC

FEDERAL-AID CONSTRUCTION IDENTIFICATION SIGNS

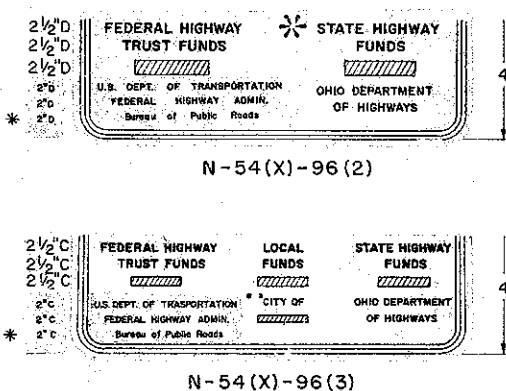
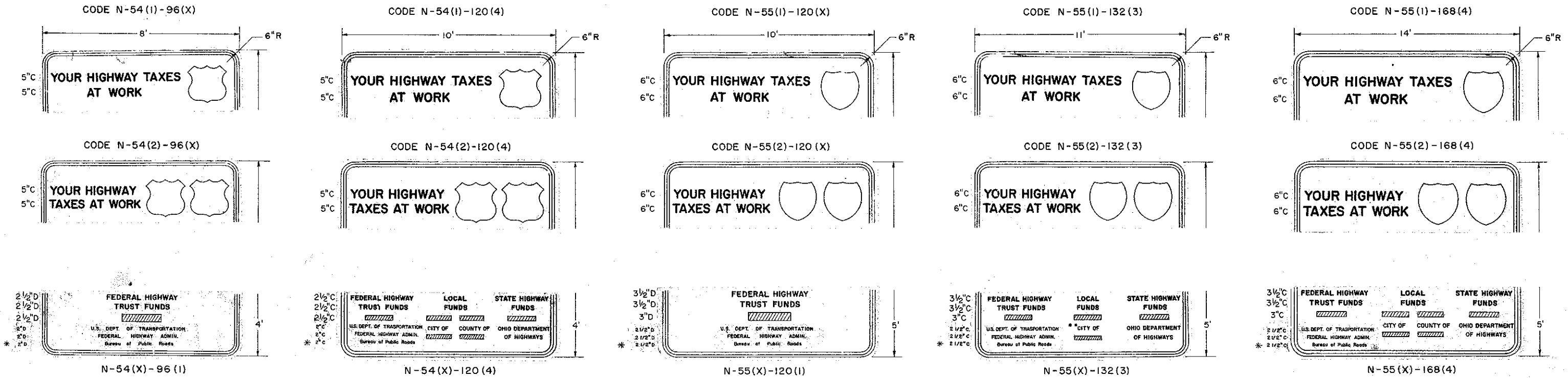

* THE WORDS "STATE HIGHWAY" SHALL BE REPLACED BY THE WORD "LOCAL", AND "OHIO DEPARTMENT OF HIGHWAYS" BY "COUNTY OF ___" OR "CITY OF ___" WHEN APPLICABLE.

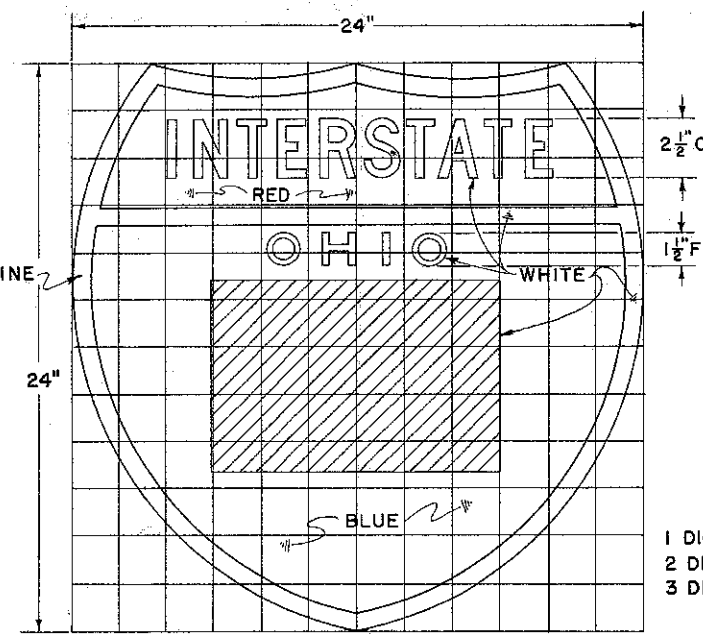
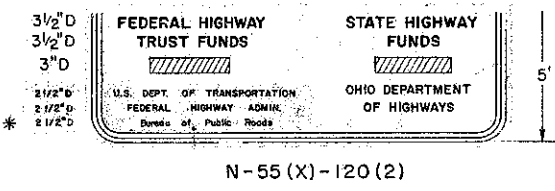

GENERAL INFORMATION

SIGN N-54 IS FOR USE ON PRIMARY AND SECONDARY SYSTEM PROJECTS. SIGN N-55 IS FOR USE ON INTERSTATE SYSTEM PROJECTS. WHEN TWO MARKERS ARE REQUIRED ON SIGN N-55 THE MARKER HAVING THE HIGHER ROUTE NUMBER SHALL BE PLACED TO THE RIGHT. WHEN TWO MARKERS ARE REQUIRED ON SIGN N-54 THE MARKER HAVING THE HIGHER ROUTE NUMBER SHALL BE PLACED TO THE RIGHT EXCEPT WHEN ONE MARKER IS U.S. AND THE OTHER IS OHIO. WHEN THIS OCCURS THE OHIO MARKER IS PLACED ON THE RIGHT REGARDLESS OF ROUTE NUMBER.

IN THE EVENT THAT MARKERS ARE NOT REQUIRED OR MORE THAN TWO MARKERS ARE REQUIRED, THE SIGN SIZE SHALL BE ADJUSTED SO AS TO PROPERLY ACCOMMODATE THE REQUIRED COPY.

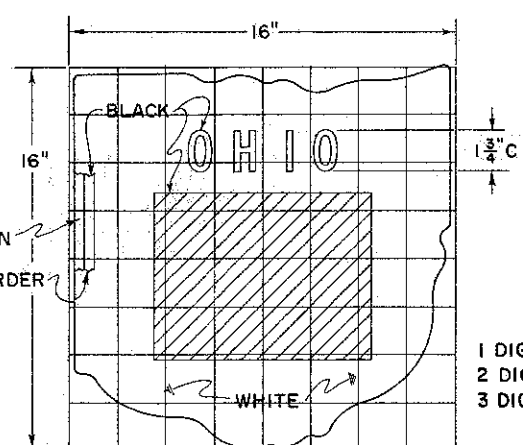
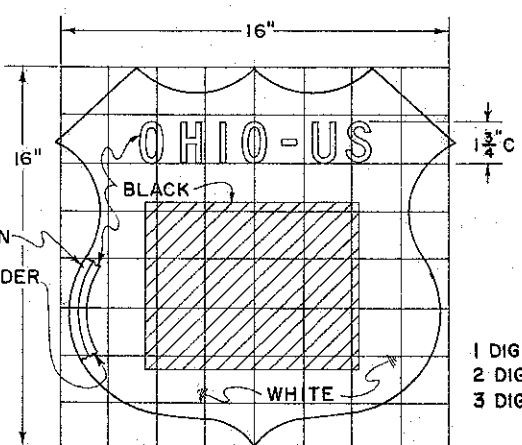

* IN "Bureau of Public Roads", WHERE UPPER AND LOWER CASE LETTERING IS SHOWN THE UPPER CASE LETTERS SHALL BE AS SPECIFIED AS TO SIZE AND SERIES. THE LOWER CASE LETTERS SHALL HAVE A LOOP HEIGHT 75% OF THE UPPER CASE HEIGHT.

M-1-16 (US)
(FOR USE WITH N-54 SIGN ONLY)

M-2-16 (OHIO)
(FOR USE WITH N-54 SIGN ONLY)

M-5-24 (INTERSTATE)
FOR USE WITH N-55 SIGN ONLY

NOTES:

ALPHABET AND LETTER SPACING
SIGN LETTERING, WHEN INDICATED ON THE PLANS AS A SERIES TYPE SUCH AS 5" OR 6" SHALL BE DESIGNED IN ACCORDANCE WITH THE "STANDARD ALPHABETS FOR HIGHWAY SIGNS OF THE BUREAU OF PUBLIC ROADS". THE SPACING BETWEEN LETTERS IS INDICATED IN THE "OHIO MANUAL OF UNIFORM TRAFFIC CONTROL DEVICES" AND IS TO BE INCREASED OR DECREASED PROPORTIONALLY SO THAT THE LEGEND

OCCUPIES THE PROPER SPACE.
COPIES OF THE ABOVE REFERENCE ARE ON FILE IN THE OFFICE OF THE DEPARTMENT OF HIGHWAYS, BUREAU OF TRAFFIC, 450 E. TOWN ST., COLUMBUS, OHIO.

SIGN MATERIAL
SIGN MATERIAL SHALL BE 1/2 INCH HIGH OR MEDIUM-DENSITY RESIN IMPREGNATED FIBER OVERLAIN PLYWOOD. IT SHALL BE DOUGLAS FIR EXTERIOR TYPE AND SHALL CONFORM TO COMMERCIAL STANDARD CS45-60, GRADE B OR BETTER.

SIGN COLORS
SIGN BACKGROUND COLOR SHALL BE WHITE USING TWO COATS OF ENAMEL. ENAMELS SHALL CONFORM TO FSS TT-E-489 C, CLASS A, AIR-DRYING. SIGN LEGEND AND BORDER SHALL BE BLACK OPAQUE SILK SCREEN PASTE OR BLACK ENAMEL.

QUANTITY, LOCATION, AND TYPE OF FEDERAL AID CONSTRUCTION IDENTIFICATION SIGNS IS SPECIFIED IN THE GENERAL NOTES.

███ CROSSHATCHED AREA DENOTES A VARIABLE THAT SHALL BE FURNISHED AT THE TIME OF CONSTRUCTION.

** THE WORD CITY SHALL BE REPLACED BY THE WORD COUNTY WHEN APPROPRIATE.

BUREAU OF TRAFFIC OHIO DEPARTMENT OF HIGHWAYS	
FEDERAL-AID CONSTRUCTION IDENTIFICATION SIGNS	DATE 3-8-63 2-25-64 6-1-65 9-15-67
STANDARD CONSTRUCTION DRAWING	FACI-1
APPROVED <i>[Signature]</i> ENGINEER OF TRAFFIC	

FEDERAL-AID CONSTRUCTION IDENTIFICATION SIGNS

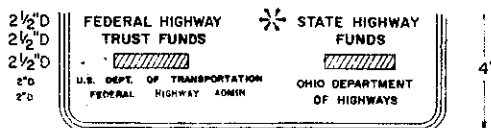
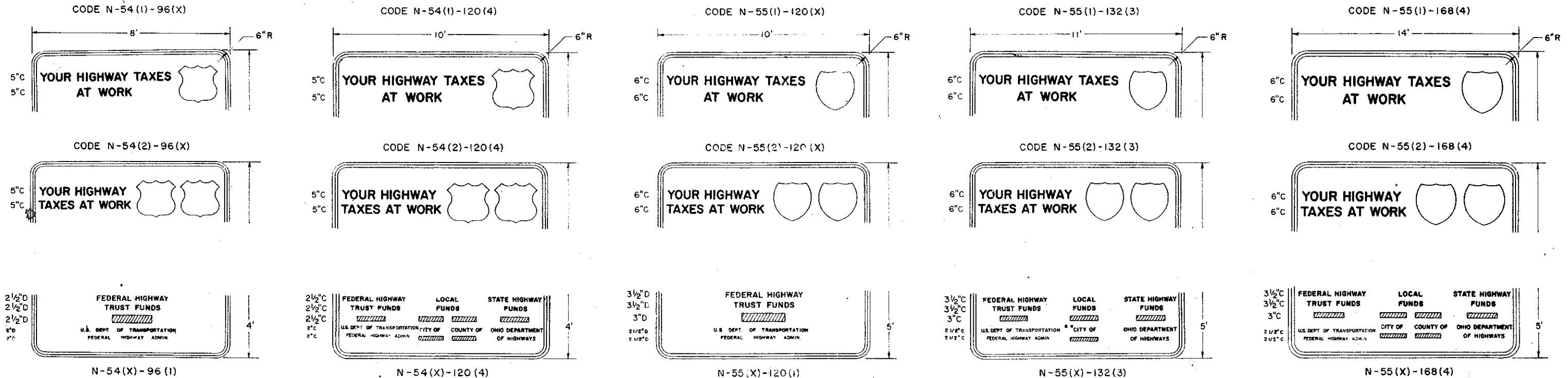

* THE WORDS "STATE HIGHWAY" SHALL BE REPLACED BY THE WORD "LOCAL", AND "OHIO DEPARTMENT OF HIGHWAYS" BY "COUNTY OF ___" OR "CITY OF ___" WHEN APPLICABLE.

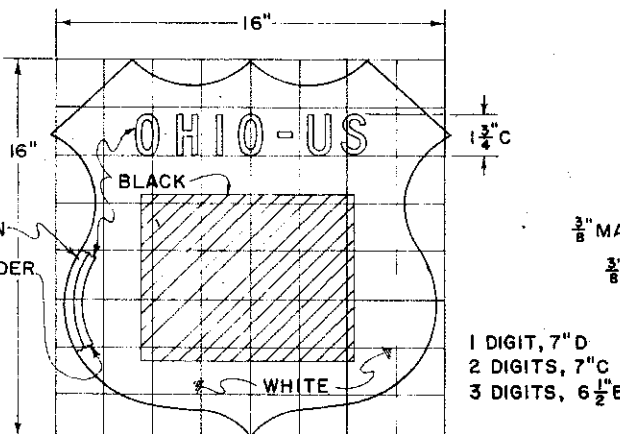
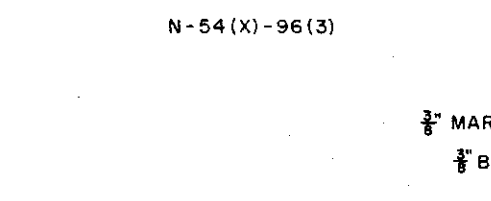
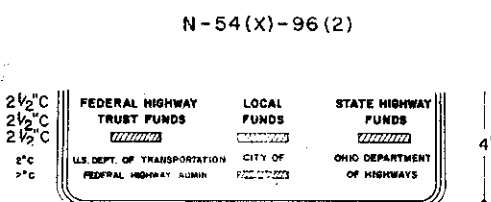
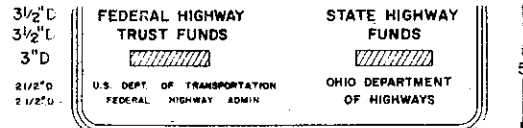

M-1-16 (US)
(FOR USE WITH N-54 SIGN ONLY)

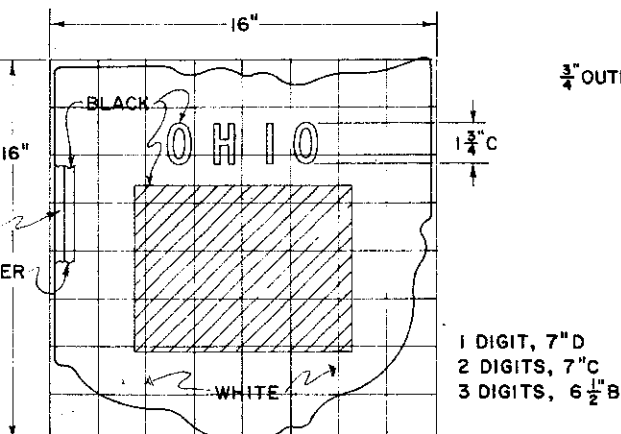

M-2-16 (OHIO)
(FOR USE WITH N-54 SIGN ONLY)

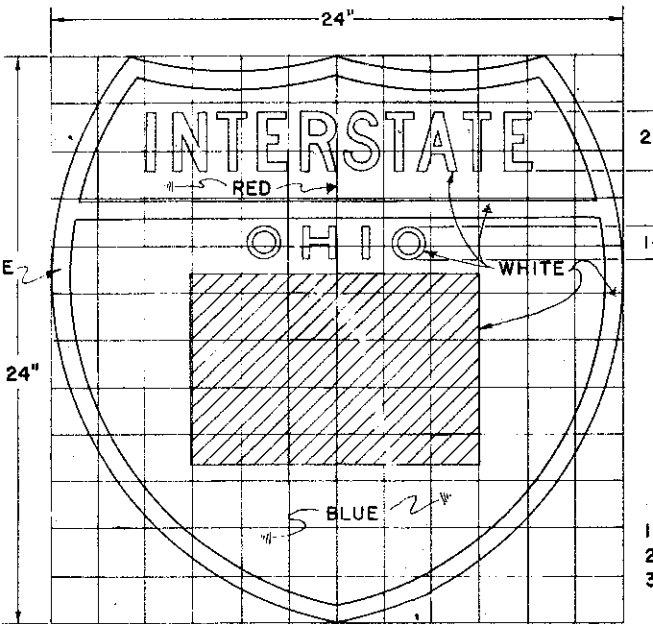

M-5-24 (INTERSTATE)
FOR USE WITH N-55 SIGN ONLY

GENERAL INFORMATION

SIGN N-54 IS FOR USE ON PRIMARY AND SECONDARY SYSTEM PROJECTS. SIGN N-55 IS FOR USE ON INTERSTATE SYSTEM PROJECTS. WHEN TWO MARKERS ARE REQUIRED ON SIGN N-55 THE MARKER HAVING THE HIGHER ROUTE NUMBER SHALL BE PLACED TO THE RIGHT. WHEN TWO MARKERS ARE REQUIRED ON SIGN N-54 THE MARKER HAVING THE HIGHER ROUTE NUMBER SHALL BE PLACED TO THE RIGHT EXCEPT WHEN ONE MARKER IS U.S. AND THE OTHER IS OHIO. WHEN THIS OCCURS THE OHIO MARKER IS PLACED ON THE RIGHT REGARDLESS OF ROUTE NUMBER.

IN THE EVENT THAT MARKERS ARE NOT REQUIRED OR MORE THAN TWO MARKERS ARE REQUIRED, THE SIGN SIZE SHALL BE ADJUSTED SO AS TO PROPERLY ACCOMMODATE THE REQUIRED COPY.

1 DIGIT, 8"D
2 DIGITS, 8"C
3 DIGITS, 7"B

NOTES:
ALPHABET AND LETTER SPACING
SIGN LETTERING, WHEN INDICATED ON THE PLANS AS A SERIES TYPE SUCH AS 5C OR 6C SHALL BE DESIGNED IN ACCORDANCE WITH THE "STANDARD ALPHABETS FOR HIGHWAY SIGNS" OF THE FEDERAL HIGHWAY ADMINISTRATION. THE SPACING BETWEEN LETTERS IS INDICATED IN THE "OHIO MANUAL OF UNIFORM TRAFFIC CONTROL DEVICES" AND IS TO BE INCREASED OR DECREASED PROPORTIONALLY SO THAT THE LEGEND

OCCUPIES THE PROPER SPACE. COPIES OF THE ABOVE REFERENCES ARE ON FILE IN THE OFFICE OF HIGHWAY DESIGN SERVICES, 25 SOUTH FRONT STREET, COLUMBUS, OHIO, 43215.
SIGN MATERIAL
SIGN MATERIAL SHALL BE 1/2 INCH HIGH OR MEDIUM-DENSITY RESIN IMPREGNATED FIBER OVERLAID PLYWOOD. IT SHALL BE DOUGLAS FIR EXTERIOR TYPE AND SHALL CONFORM TO COMMERCIAL STANDARD CS45-60, GRADE B OR BETTER.

SIGN COLORS
SIGN BACKGROUND COLOR SHALL BE WHITE USING TWO COATS OF ENAMEL. PASTE AND ENAMELS SHALL BE OF ALL WEATHER RESISTING HIGH QUALITY. SIGN LEGEND AND BORDER SHALL BE BLACK OPAQUE SILK SCREEN PASTE OR BLACK ENAMEL.

QUANTITY, LOCATION, AND TYPE OF FEDERAL AID CONSTRUCTION IDENTIFICATION SIGNS IS SPECIFIED IN THE GENERAL NOTES.
HATCHED AREA DENOTES A VARIABLE THAT SHALL BE FURNISHED AT THE TIME OF CONSTRUCTION.
** THE WORD CITY SHALL BE REPLACED BY THE WORD COUNTY WHEN APPROPRIATE.

OFFICE OF HIGHWAY DESIGN SERVICES
OHIO DEPARTMENT OF HIGHWAYS

FEDERAL AID CONSTRUCTION IDENTIFICATION SIGNS

STANDARD CONSTRUCTION DRAWING FACI-1

APPROVED *M. J. Cunningham*
ENGINEER OF DESIGN SERVICES

DATE
3-8-68
2-25-64
6-1-65
9-15-67
4-20-71