

X:\Standards\Publications\SCD\Distributions\scd_2013-01-18\MGS-6.2_1-18-2013.dgn 08-JAN-2013 2:58PM mruppe

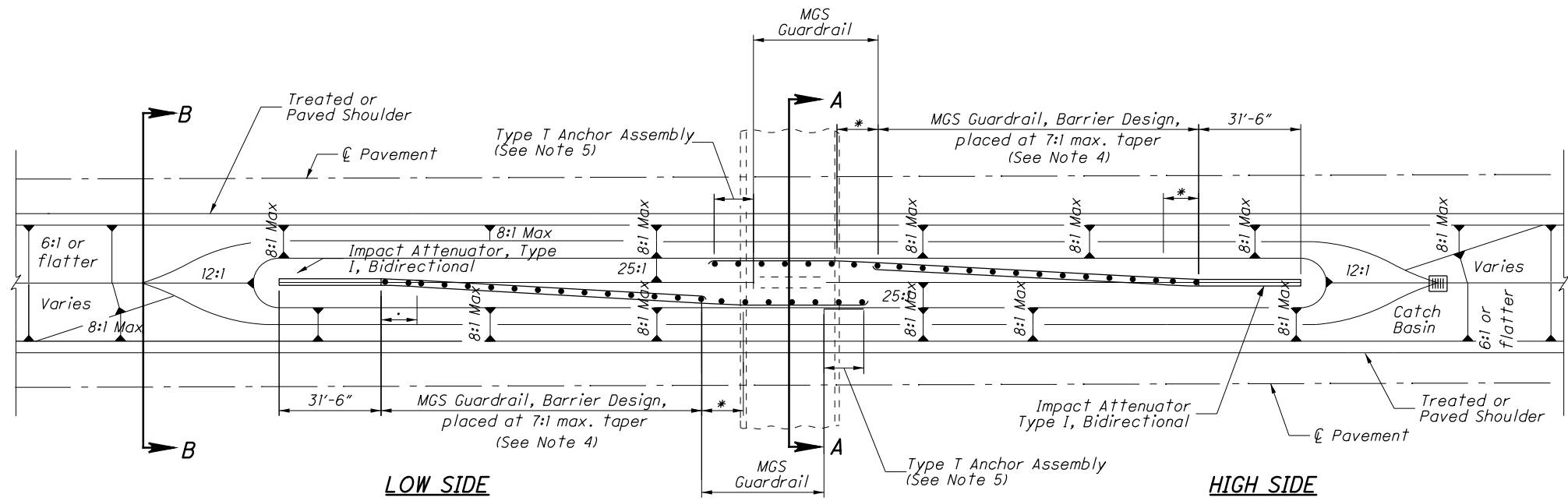

LOW SIDE

HIGH SIDE

DESIGN A
Narrow Median (See Note 2)

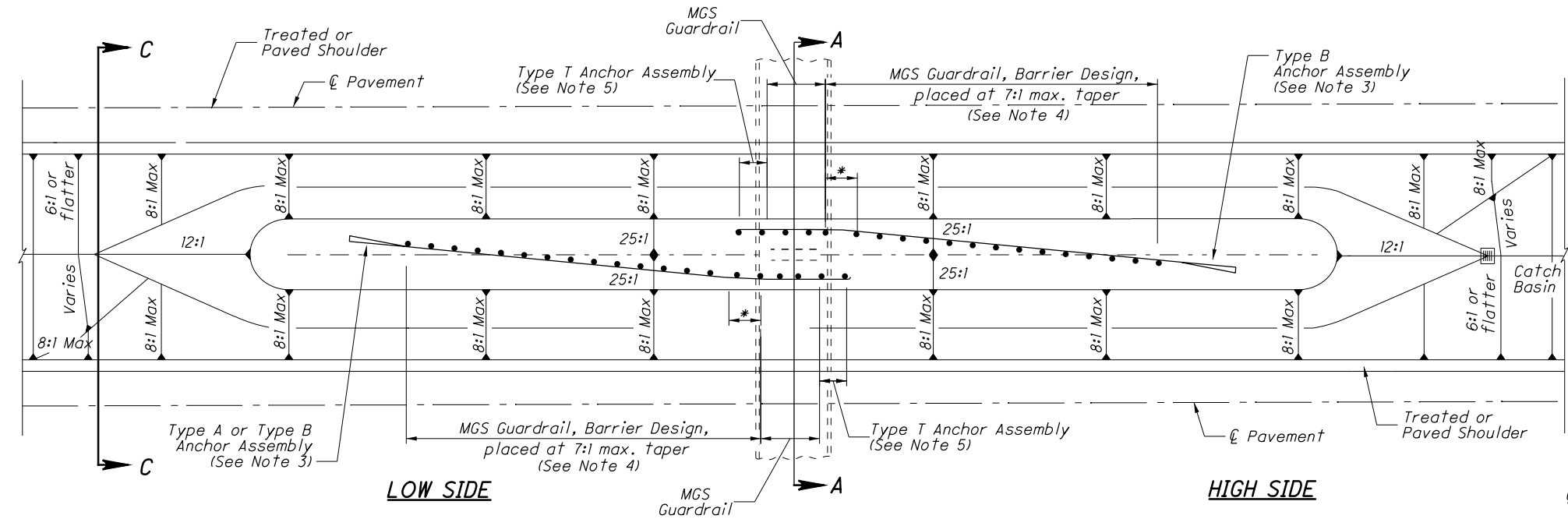

LOW SIDE

HIGH SIDE

DESIGN B
Wide Median (See Note 3)

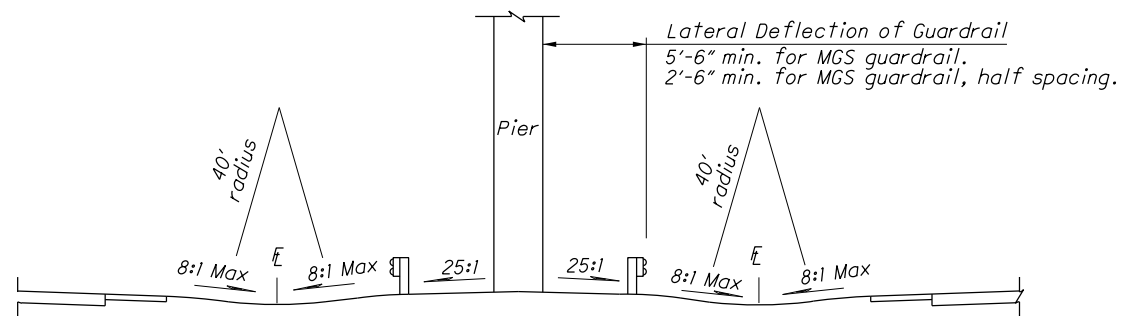

SECTION A-A

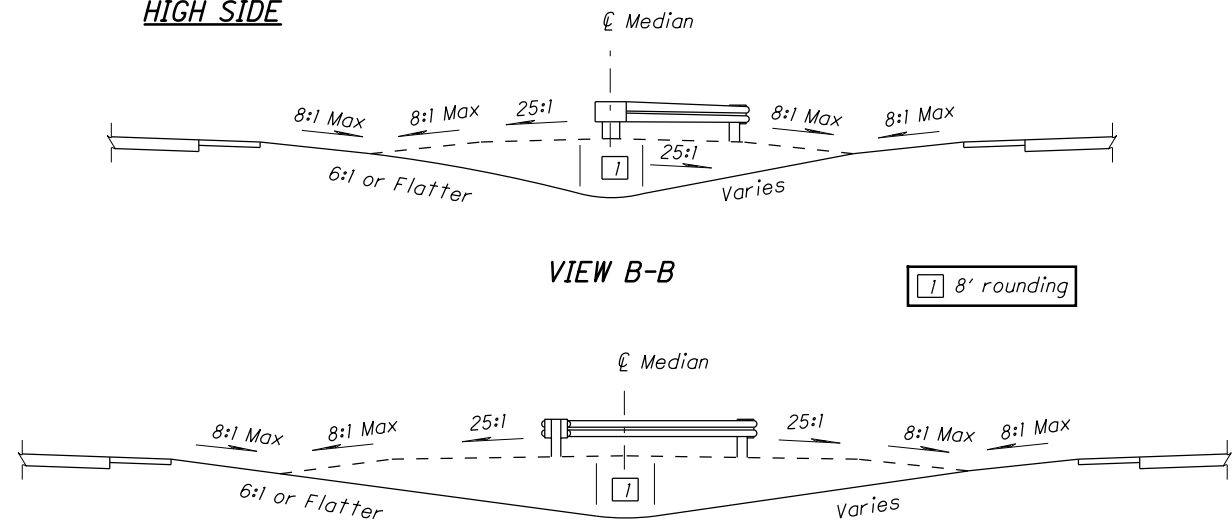

VIEW B-B

VIEW C-C

NOTES

- 1) The length of guardrail needed shall be determined according to methods contained in the **Location & Design Manual, Volume 1, Section 602.**
 - 2) Use **DESIGN "A"** in the narrow Medians where the end of the guardrail run extends into the Clear Zone of the opposite side of traffic.

In Medians where the guardrail run would otherwise extend beyond the centerline of the median, the guardrail run should be turned to follow the centerline using a standard flare arc. The plans shall clearly indicate what portion of the flared guardrail run is to be constructed using barrier guardrail.
 - 3) Use **DESIGN "B"** where the end of the guardrail run shielding the piers lies outside the clear zone of the opposite side of traffic.
 - 4) Provide 8:1 Max or flatter cross-slopes in front of guardrail. Other slopes are shown in the median to suggest a grading and drainage plan, however for complete details see the construction plans.
 - 5) Install Type T Anchor Assemblies (see **SCD MGS-4.2**) on the trailing ends of the guardrail beyond the bridge piers (downstream from traffic flow.)
 - 6) The "HIGH SIDE" and the "LOW SIDE" designations are shown in the reference to the drainage design and are dependent upon the longitudinal slop in the median.
- * Provide 25' Guardrail Flare Arc (7:1 Max).

THIS IS A NEW DRAWING

STANDARD ROADWAY CONSTRUCTION DRAWING

OFFICE OF ROADWAY ENGINEERING

STATUS: ENGINEER

STATE OF OHIO DEPARTMENT OF TRANSPORTATION

SCD NUMBER
MGS-6.2

MEDIAN GUARDRAIL AT PIERS

M. Ruppe

ADMINISTRATOR
Michael Blune

DATE
01-18-2013

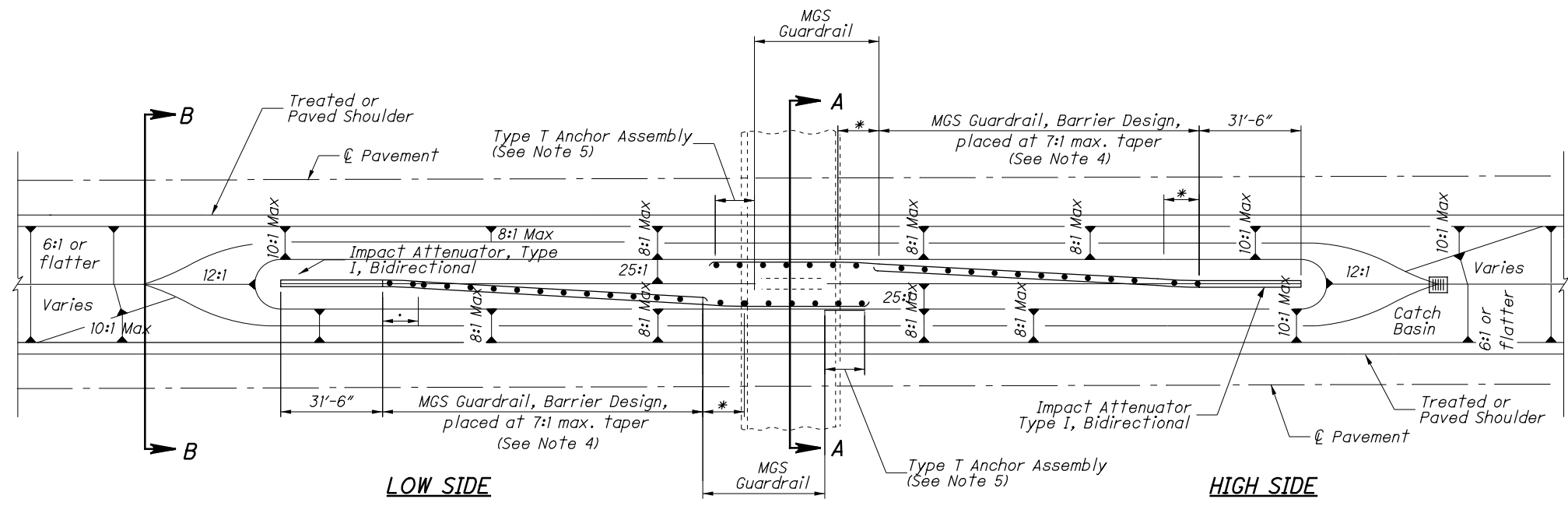

LOW SIDE

HIGH SIDE

DESIGN A
Narrow Median (See Note 2)

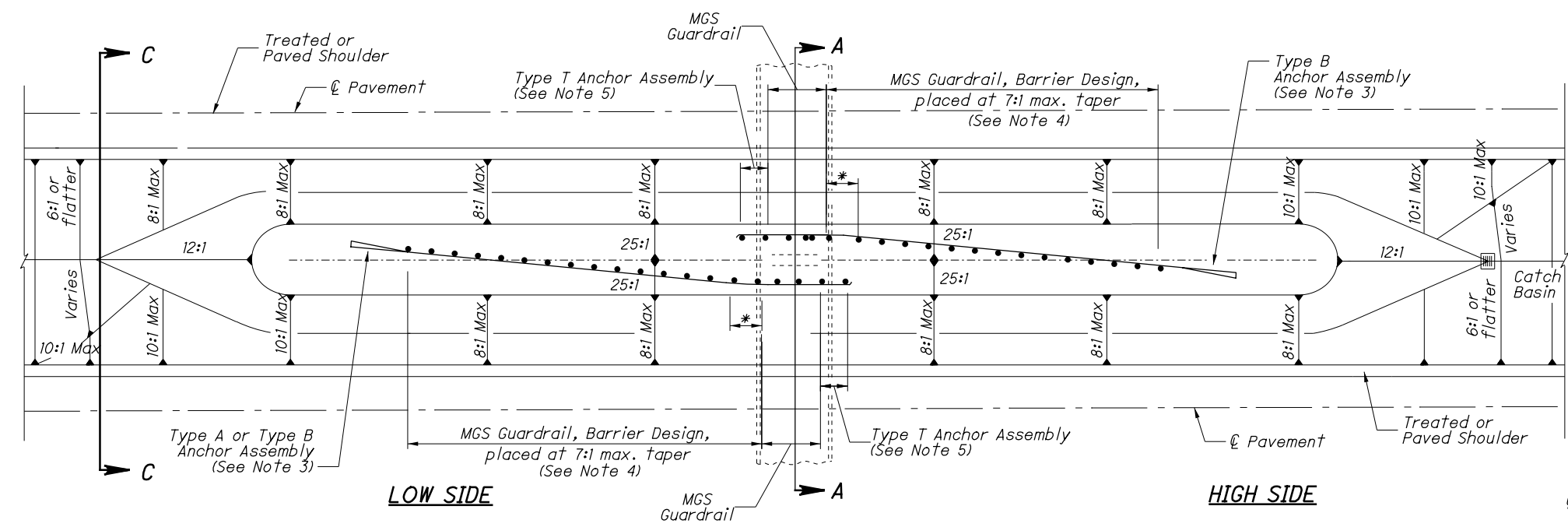

LOW SIDE

HIGH SIDE

DESIGN B
Wide Median (See Note 3)

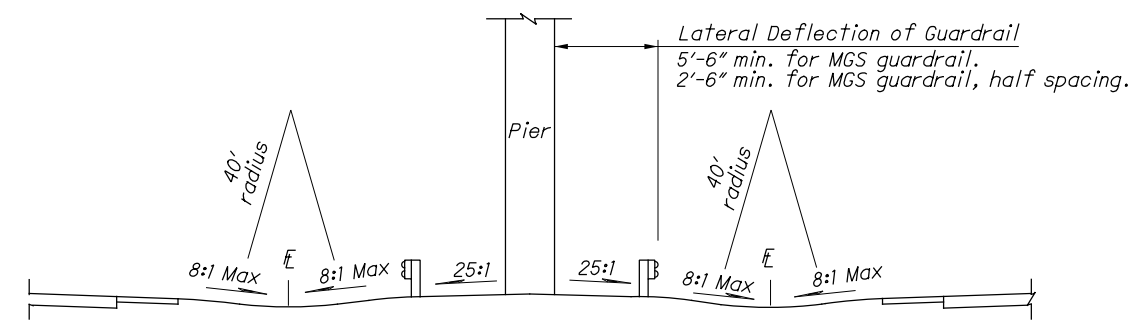

SECTION A-A

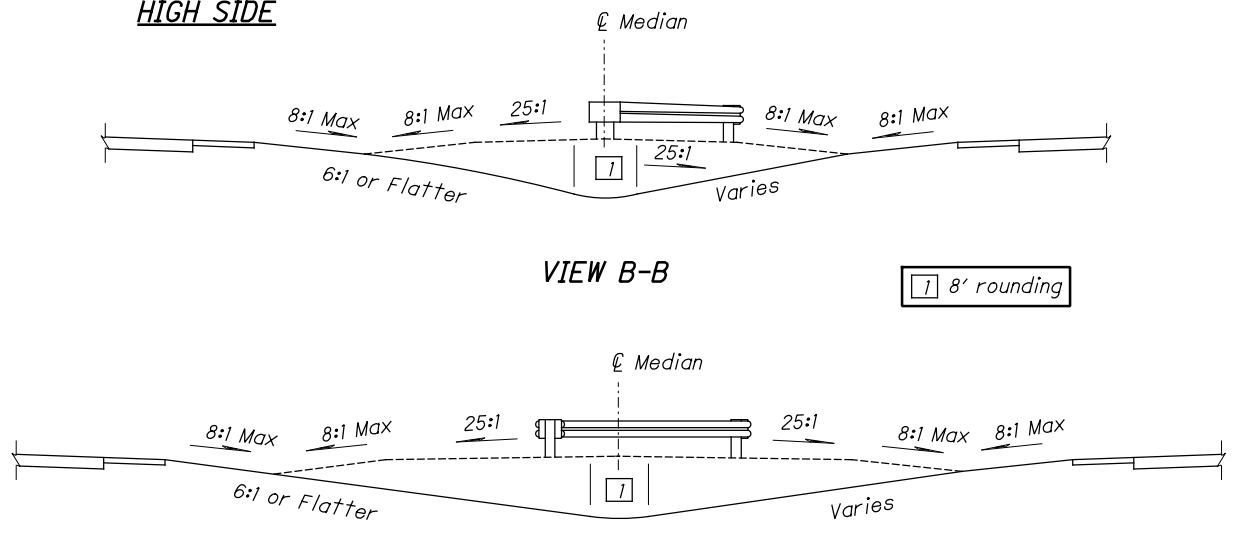

VIEW B-B

VIEW C-C

NOTES

- 1) The length of guardrail needed shall be determined according to methods contained in the **Location & Design Manual, Volume 1, Section 602**.
 - 2) Use **DESIGN "A"** in the narrow Medians where the end of the guardrail run extends into the Clear Zone of the opposite side of traffic.
 - 3) Use **DESIGN "B"** where the end of the guardrail run shielding the piers lies outside the clear zone of the opposite side of traffic.
 - 4) Provide 8:1 Max or flatter cross-slopes in front of guardrail. Other slopes are shown in the median to suggest a grading and drainage plan, however for complete details see the construction plans.
 - 5) Install Type T Anchor Assemblies (see **SCD MGS-4.2**) on the trailing ends of the guardrail beyond the bridge piers (downstream from traffic flow).
 - 6) The "HIGH SIDE" and the "LOW SIDE" designations are shown in the reference to the drainage design and are dependent upon the longitudinal slop in the median.
- * Provide 25' Guardrail Flare Arc (7:1 Max).

THIS DRAWING REPLACES MGS-6.2 DATED 01-18-2013.

STANDARD ROADWAY CONSTRUCTION DRAWING

MGS-6.2
MEDIAN GUARDRAIL AT PIERS

OFFICE OF
ROADWAY
ENGINEERING

SDS
ENGINEER
D. Fisher

STATE OF OHIO DEPARTMENT OF
TRANSPORTATION ADMINISTRATOR
David L. Holstein

REVISION DATE
7-15-2016

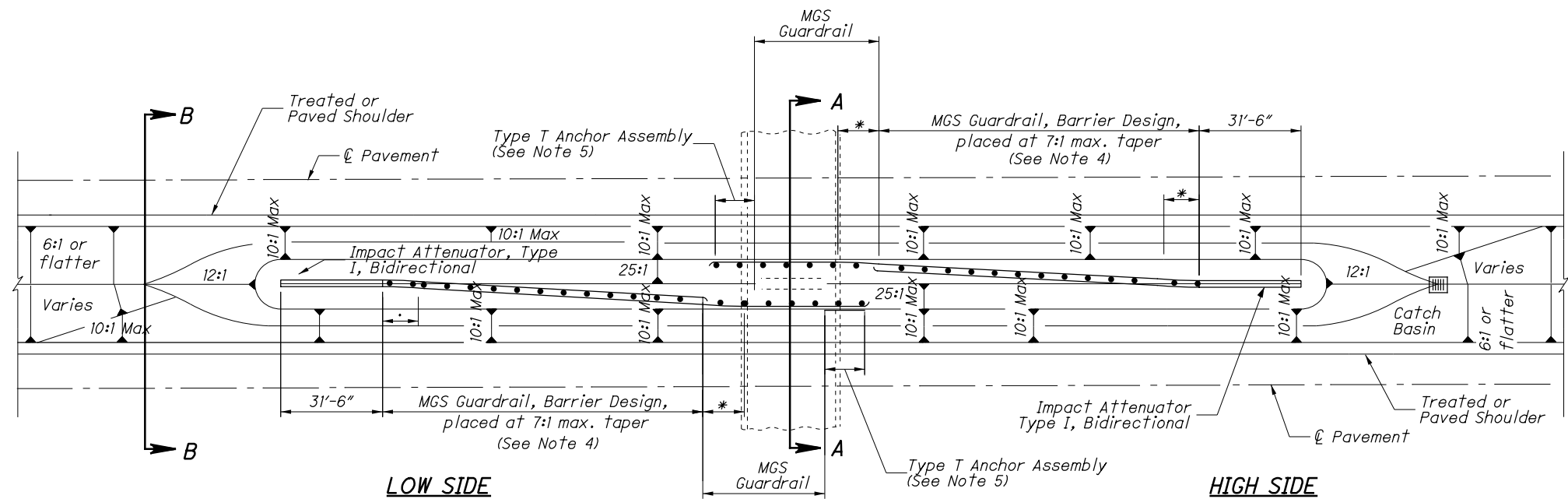

LOW SIDE

HIGH SIDE

DESIGN A
Narrow Median (See Note 2)

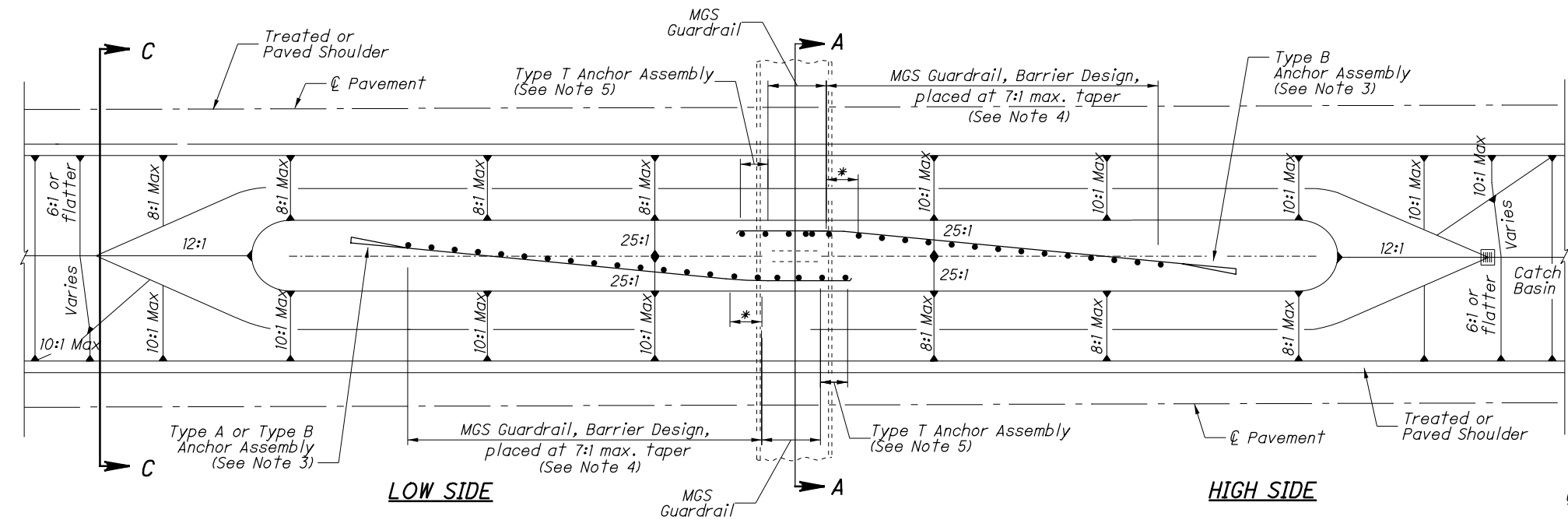

LOW SIDE

HIGH SIDE

DESIGN B
Wide Median (See Note 3)

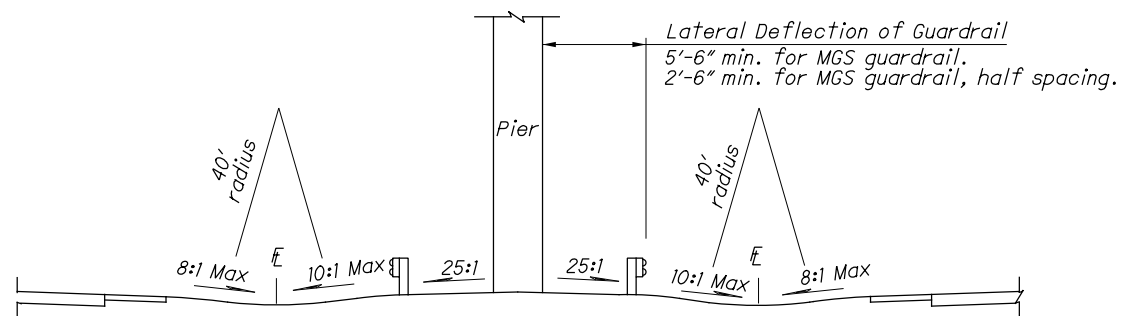

SECTION A-A

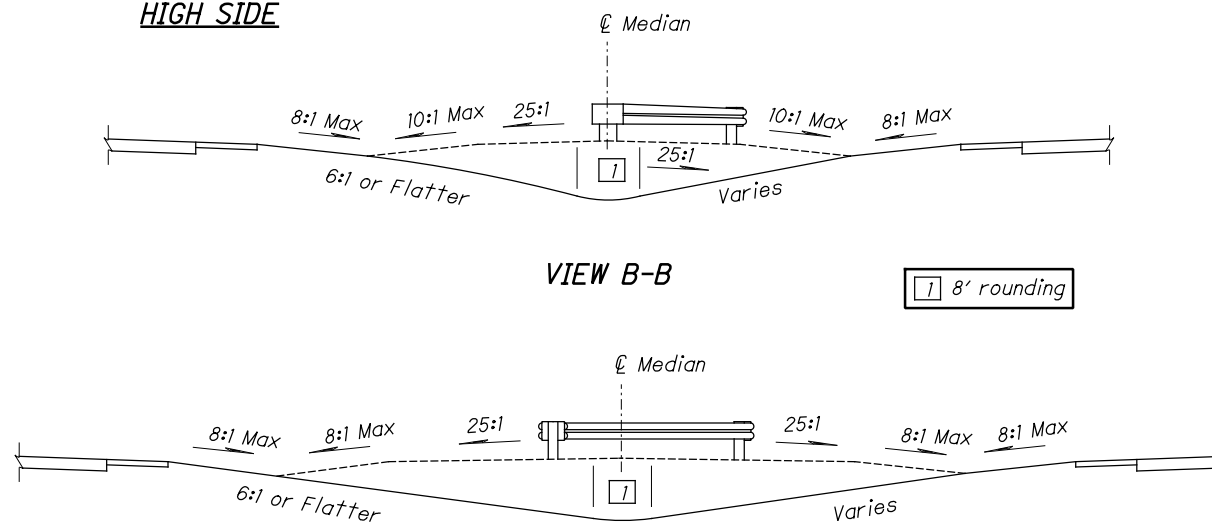

VIEW B-B

VIEW C-C

NOTES

1) The length of guardrail needed shall be determined according to methods contained in the **Location & Design Manual, Volume 1, Section 602**.

2) Use **DESIGN "A"** in the narrow Medians where the end of the guardrail run extends into the Clear Zone of the opposite side of traffic.

In Medians where the guardrail run would otherwise extend beyond the centerline of the median, the guardrail run should be turned to follow the centerline using a standard flare arc. The plans shall clearly indicate what portion of the flared guardrail run is to be constructed using barrier guardrail.

3) Use **DESIGN "B"** where the end of the guardrail run shielding the piers lies outside the clear zone of the opposite side of traffic.

4) Provide 8:1 Max or flatter cross-slopes in front of guardrail. Other slopes are shown in the median to suggest a grading and drainage plan, however for complete details see the construction plans.

5) Install Type T Anchor Assemblies (see **SCD MGS-4.2**) on the trailing ends of the guardrail beyond the bridge piers (downstream from traffic flow).

6) The "HIGH SIDE" and the "LOW SIDE" designations are shown in the reference to the drainage design and are dependent upon the longitudinal slope in the median.

* Provide 25' Guardrail Flare Arc (7:1 Max).

THIS DRAWING REPLACES MGS-6.2 DATED 7-15-2016.

STANDARD ROADWAY CONSTRUCTION DRAWING

SCD NUMBER
MGS-6.2

MEDIAN GUARDRAIL AT PIERS

OFFICE OF
ROADWAY
ENGINEERING

SENIOR
ENGINEER
D. Fisher

STATE OF OHIO DEPARTMENT OF
TRANSPORTATION ADMINISTRATOR
David L. Holstein

REVISION DATE
1-19-2018