

FRONT ELEVATION

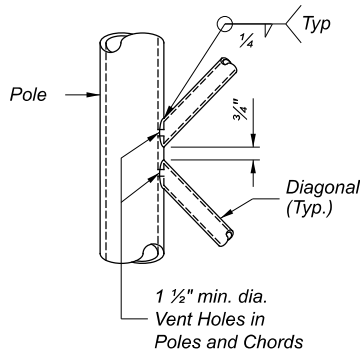

DETAIL "F"
 END FRAME AND TRUSS
 END JOINT DETAILS
 (See Note 6 on Sheet 2/2)

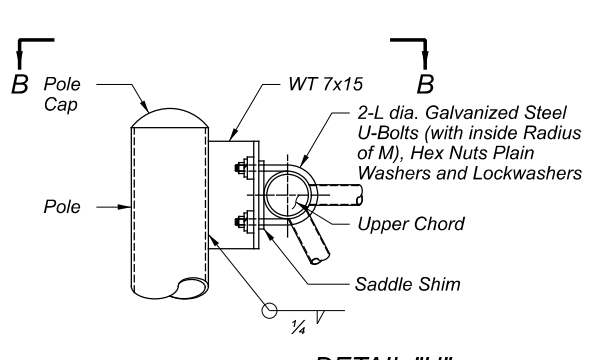

DETAIL "H"
 UPPER SPAN SUPPORT

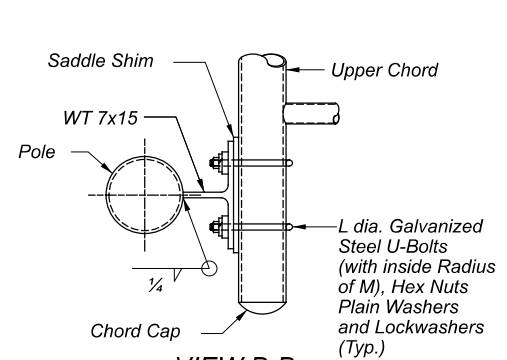

VIEW B-B

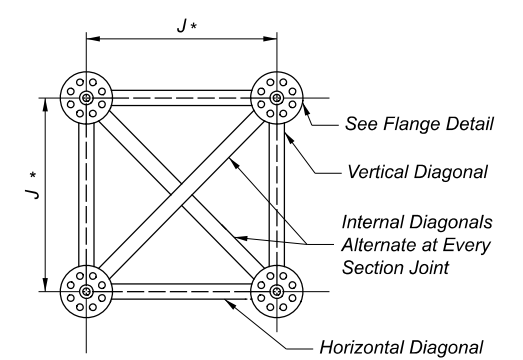

SECTION A-A

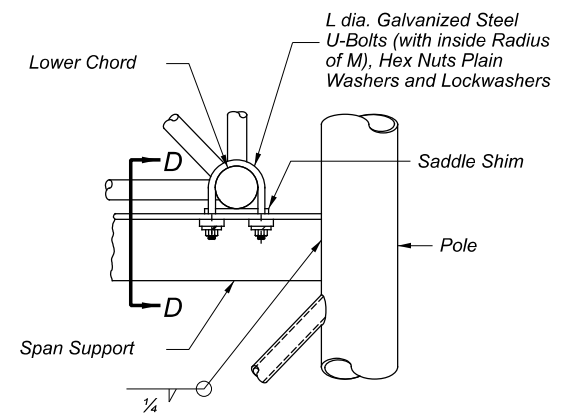

DETAIL "E"
 LOWER SPAN SUPPORT

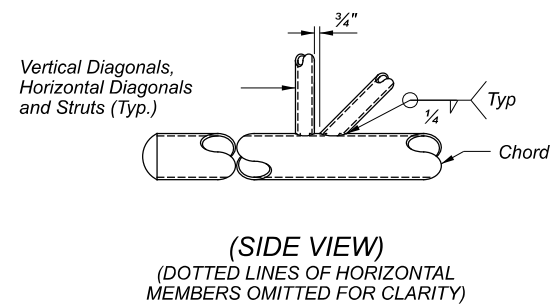

(SIDE VIEW)
 (DOTTED LINES OF HORIZONTAL MEMBERS OMITTED FOR CLARITY)

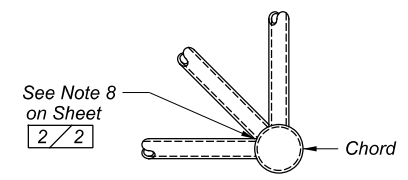

DETAIL "G"
 TRUSS END JOINT DETAILS

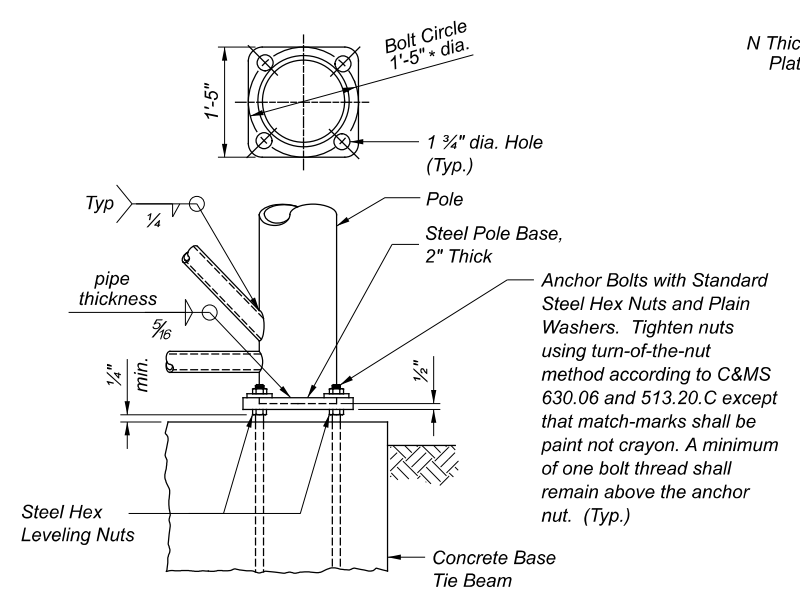

POLE BASE DETAIL

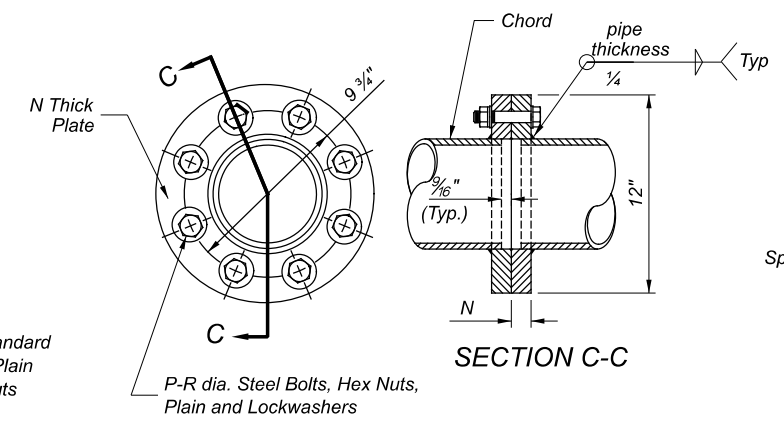

FLANGE DETAIL

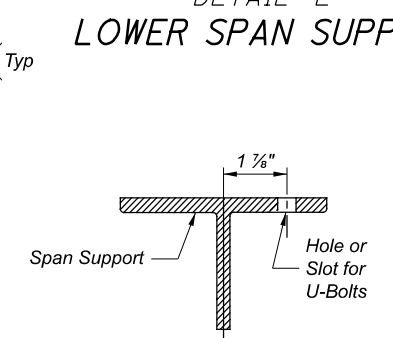

SECTION D-D
 STRUCTURAL TEE
 SPAN SUPPORT

LEGEND:
 * = Required dimension. See Note 2 on Sheet 2/2

NOTES:
 For Notes and Table see Sheet 2/2

NOTES:

1. The design of the Steel Truss Overhead Sign Support meets the requirements of the AASHTO LRFD Specifications for Structural Supports for Highway Signs, Luminaires, and Traffic Signals, First Edition 2015 (LRFDLTS-1) and all interim releases prior to the bid date of the project.
2. Dimensions marked as required shall be as indicated on the drawing and shall not be altered.
3. ODOT permits modifications to accommodate minor variations in manufacturing processes and detailing between suppliers. Modifications shall not decrease the main tube section moduli as depicted in this drawing. Calculations are required for any modifications to the information shown on the drawings. Modifications shall meet the requirements of LRFDLTS-1 and the design criteria shown in Note 19. Calculations shall be stamped by a Professional Engineer registered in the state of Ohio and shall be submitted for review and acceptance with the shop drawings.
4. For sign attachment assemblies to be furnished with this support, construction details, and location of handholes, see Standard Construction Drawings (SCDs) TC-22.10 and TC-22.20.
5. For foundation details, see SCD TC-21.11.
6. For truss bracing members, one internal diagonal is required at each end of each section and at the panel point nearest the centerline of the truss section when the section exceeds 25' in length. Tube-to-tube type butted connections are required. Tube-to-gusset plate type connections are not permitted.
7. Camber the truss for full dead load including signs a minimum of 1" for a span of 50' or less. Increase the camber ¼" for each 5' of span over 50'.
8. Internal diagonals only may be relocated from the indicated position to avoid weld joint overlap.
9. Structural steel plate and WT sections shall meet the requirements of C&MS 630 and 711.01 with the following limitations:

Structural steel - ASTM A 709 Grade 50 (A572)
(Not Grade 36, 50W or 70W)
10. All material shall meet the requirements of C&MS 730 with the following limitations:

Steel tube and pipe - ASTM A 500 Grade B
(Not ASTM A 53 Grade B and ASTM A 501)

Steel hardware - Galvanizing - ASTM A 153 (Hot-dipped)
(Not ASTM B 695 Class 50)
11. Nuts shall meet the requirements of C&MS 730.08 and shall also meet the requirements of ASTM A 563 Grade DH or A 194 Grade 2H.
12. Flat washers shall meet the requirements of C&MS 730.08 and shall also meet the requirements of ASTM F 436.
13. Anchor bolts shall meet the requirements of C&MS 630, 711.02, 730.02 and 732.11 except that 730.02 shall be modified to require the galvanizing limits to be the full length of the anchor bolts not at least 2 inches beyond the threads.
14. Anchor bolt nuts shall meet the requirements of ASTM A 563 Grade DH or A 194 Grade 2H.
15. Anchor bolt washers shall meet the requirements of ASTM F 436 Type 1 (Hot-dip galvanized) according to ASTM A 153.
16. Holes for high-strength bolts and bearing bolts shall meet the requirements of C&MS 513.19. Modifications to the holes must be approved by the Engineer. Enlarging or slotting holes to match mis-aligned anchor bolts will not be permitted.
17. All welds shall be inspected according to the requirements of C&MS 630.06 and AWS D1.1 Structural Welding Code - Steel. A report of the welding inspection shall be submitted to the ODOT Office of Material Management Structural Welding and Materials Engineer.
18. Saddle shims can be aluminum castings meeting the requirements of C&MS 730.14, preformed bearing pads meeting the requirements of C&MS 516 and 711.21 or ASTM A 709 Grade 36 steel galvanized according to C&MS 711.02.
19. Design Criteria:

Load Parameters:

Wind Load: 1700-year MRI Basic Wind Speed Map, 120 mph Design Wind Speed

Service Life: Infinite per LRFDLTS-1 11.9.3

Service I Wind Velocity: 76 mph per LRFDLTS-1 Table 3.4.1 and Figure 3.8-4b

ADT: Greater than 10,000

Serviceability Parameters:

Maximum Vertical Deflection of Horizontal Support Resulting from Service I Load Combination (Dead Load + Wind): L/150 per LRFDLTS-1 10.4.1

Fatigue Parameters:

Fatigue Category: I

Natural Wind Gust: Include

Truck-Induced Gust: Include

Galloping: Do not include

Design	Maximum Span (Note 20)	Maximum Sign Area (ft ²) (Note 20)	Chords	Vertical Diagonals	Horizontal Diagonals	Struts	End Frame Pole	End Frame Diagonal and Strut	Span Support	J	K	L	M	N	P	R
Design 1	75'	600	5.563" x .258"	1.90" x .145"	1.90" x .145"	1.90" x .145"	10.75" x .25"	2.875" x .203"	WT6x13	3'-0"	5'-0"	¾"	2⅞"	1"	6	⅞"
Design 2	120'	700	6.625" x .375"	2.375" x .218"	2.375" x .218"	2.375" x .218"	10.75" x .25"	2.875" x .203"	WT7x15	5'-0"	7'-0"	¾"	3⅜"	1"	6	1"
Design 3	150'	1150	6.625" x .562"	2.875" x .203"	2.875" x .203"	2.875" x .203"	10.75" x .365"	3" x .216"	WT7x15	5'-0"	7'-0"	¾"	3⅜"	1 ¼"	8	1"

All members are HSS round sections (outside diameter x nominal wall thickness) unless otherwise noted.

All tube diameters and wall thicknesses are minimums.